

# microcilindri ISO 6432

minicylinders ISO 6432



- Conformi alla norma ISO 6432  
*Compliant to norm ISO 6432*
- Grande affidabilità e lunga durata  
*High reliability and long life time*
- Versione a doppio effetto, magnetica o non magnetica  
*Magnetic or non-magnetic double acting version*
- Versione a semplice effetto non magnetica  
*Non-magnetic single acting version*
- Esecuzioni speciali a richiesta  
*Special versions on request*



## Materiali

Camicia: INOX

Stelo: INOX

Testate: alluminio anodizzato

Guarnizioni: NBR o VITON

Magnete: plastroferrite

## Materials

Barrel: stainless steel

Piston-rod: stainless steel

End-cups: aluminium (anodize treatment)

Sealings: NBR or VITON

Magnet: magnetic iron compound

## Forze di ritorno della molla per cilindri a semplice effetto

*Return spring forces for single acting cylinders*

alesaggio <i>bore</i>	forza di ritorno della molla <i>return spring force</i>			stato della molla <i>spring status</i>
	corsa 10 [stroke]	corsa 25 [stroke]	corsa 50 [stroke]	
10	4.1 N	3.5 N	2.6 N	a riposo [at rest]
	4.5 N	4.5 N	4.5 N	compressa [compressed]
12	5.5 N	4.8 N	3.5 N	a riposo [at rest]
	6 N	6 N	6 N	compressa [compressed]
16	16.5 N	13.7 N	9 N	a riposo [at rest]
	18.3 N	18.3 N	18.3 N	compressa [compressed]
20	19 N	15.5 N	9.5 N	a riposo [at rest]
	21.5 N	21.5 N	21.5 N	compressa [compressed]
25	27 N	24 N	13.5 N	a riposo [at rest]
	29 N	29 N	29 N	compressa [compressed]

Pressione di esercizio <i>Working pressure</i>	max 10 bar max 1 MPa
Temperatura di esercizio <i>Temperature range</i>	max +60°C
Alesaggi <i>Bores</i>	10; 12; 16; 20; 25 mm
Corse <i>Strokes</i>	10 ... 320 mm
Paracolpi meccanici <i>Mechanical cushioning</i>	Standard su tutta la gamma <i>Standard on the whole range</i>
Ammortizzo pneumatico <i>Pneumatic cushioning</i>	Disponibile per alesaggio 20 e 25 <i>Available for bore 20 and 25</i>
Fluido <i>Fluid</i>	Aria filtrata 50µ con o senza lubrificazione <i>50µ filtered, lubricated or non lubricated air</i>



## chiave di codifica

key to codes

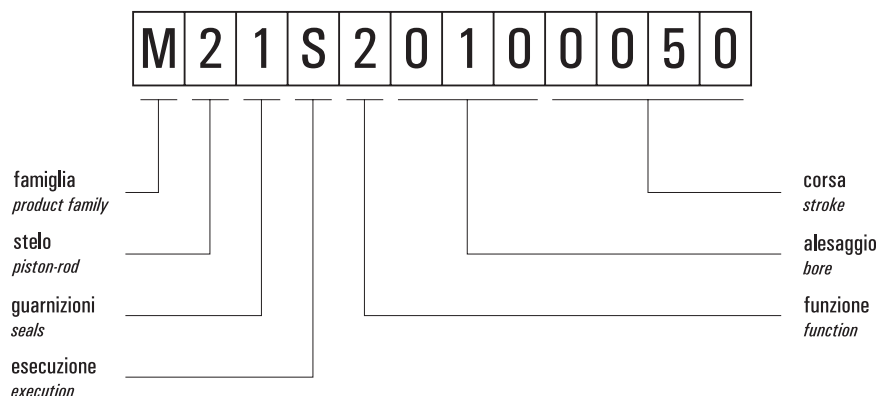

### Famiglia *[product family]*

**M** microcilindri ISO 6432 *[minicylinders ISO 6432]*

### Stelo *[piston-rod]*

**2** INOX *[stainless steel]*

### Guarnizioni *[seals]*

**1** NBR

**2** VITON

### Esecuzione *[execution]*

**S** non magnetico *[non-magnetic]*

**M** magnetico *[magnetic]*

**A** non magnetico predisposto per bloccastelo *[non-magnetic with rod lock adaptor]*

**B** magnetico predisposto per bloccastelo *[magnetic with rod lock adaptor]*

### Funzione *[function]*

**1** semplice effetto non ammortizzato molla anteriore  
*[single acting front spring without pneumatic cushioning]*

**2** doppio effetto non ammortizzato  
*[double acting without pneumatic cushioning]*

**3** doppio effetto ammortizzato  
*[double acting with pneumatic cushioning]*

**4** doppio effetto non ammortizzato stelo passante  
*[double acting without pneumatic cushioning, with passing-through rod]*

**5** doppio effetto ammortizzato stelo passante  
*[double acting with pneumatic cushioning and passing-through rod]*

**6** semplice effetto non ammortizzato molla posteriore  
*[single acting back spring without pneumatic cushioning]*



## versioni disponibili

available versions

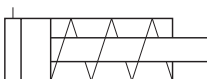
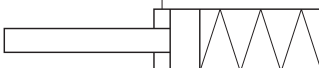
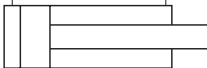
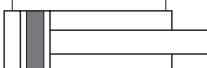
	alesaggio		corsa bore					
	stroke	bore	10	12	16	20	25	
<b>semplice effetto molla anteriore</b> <i>single acting front spring</i> <b>non magnetico</b> <i>non-magnetic</i> <b>non ammortizzato</b> <i>without pneumatic cushioning</i>								<b>OPZIONI</b> <i>options</i> Lo standard è evidenziato in grigio <i>The standard is marked with grey background</i>
	10	X	X	X	X	X	X	
	25	X	X	X	X	X	X	
	50	X	X	X	X	X	X	
								
<b>semplice eff. molla posteriore</b> <i>single acting back spring</i> <b>non magnetico</b> <i>non-magnetic</i> <b>non ammortizzato</b> <i>without pneumatic cushioning</i>				X	X	X		<b>OPZIONI</b> <i>options</i> Lo standard è evidenziato in grigio <i>The standard is marked with grey background</i>
	25			X	X	X		
	50			X	X	X		
								
<b>doppio effetto</b> <i>double acting</i> <b>non magnetico</b> <i>non-magnetic</i> <b>non ammortizzato</b> <i>without pneumatic cushioning</i>								<b>OPZIONI</b> <i>options</i> Lo standard è evidenziato in grigio <i>The standard is marked with grey background</i>
	10	X	X	X	X	X	X	
	25	X	X	X	X	X	X	
	50	X	X	X	X	X	X	
	80	X	X	X	X	X	X	
	100	X	X	X	X	X	X	
	125	X	X	X	X	X	X	
	160	X	X	X	X	X	X	
	200	X	X	X	X	X	X	
	250			X	X	X		
320			X	X	X			
								
<b>doppio effetto</b> <i>double acting</i> <b>magnetico</b> <i>magnetic</i> <b>non ammortizzato</b> <i>without pneumatic cushioning</i>								<b>OPZIONI</b> <i>options</i> Lo standard è evidenziato in grigio <i>The standard is marked with grey background</i>
	10	X	X	X	X	X	X	
	25	X	X	X	X	X	X	
	50	X	X	X	X	X	X	
	80	X	X	X	X	X	X	
	100	X	X	X	X	X	X	
	125	X	X	X	X	X	X	
	160	X	X	X	X	X	X	
	200	X	X	X	X	X	X	
	250			X	X	X		
320			X	X	X			
								

## versioni disponibili

available versions

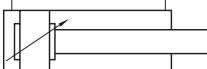
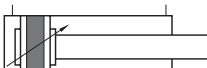
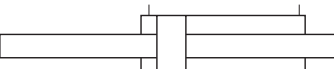
	alesaggio		10	12	16	20	25	
	corsa	bore						
	stroke							
<p><b>doppio effetto</b> <i>double acting</i> <b>non magnetico</b> <i>non-magnetic</i> <b>ammortizzato</b> <i>with pneumatic cushioning</i></p> 								<p><b>OPZIONI</b> <i>options</i></p> <p>Lo standard è evidenziato in grigio <i>The standard is marked with grey background</i></p> <p><b>materiale stelo</b> <i>[piston-rod material]</i></p> <p><b>INOX</b> <i>stainless steel</i></p> <p><b>materiale guarnizioni</b> <i>[seals material]</i></p> <p><b>NBR</b>      <b>VITON</b></p> <p><b>predisposizione per bloccastelo</b> <i>rod lock adaptor</i></p>
	10							
	25					X	X	
	50					X	X	
	80					X	X	
	100					X	X	
	125					X	X	
	160					X	X	
	200					X	X	
	250					X	X	
320					X	X		
<p><b>doppio effetto</b> <i>double acting</i> <b>magnetico</b> <i>non-magnetic</i> <b>ammortizzato</b> <i>with pneumatic cushioning</i></p> 								<p><b>OPZIONI</b> <i>options</i></p> <p>Lo standard è evidenziato in grigio <i>The standard is marked with grey background</i></p> <p><b>materiale stelo</b> <i>[piston-rod material]</i></p> <p><b>INOX</b> <i>stainless steel</i></p> <p><b>materiale guarnizioni</b> <i>[seals material]</i></p> <p><b>NBR</b>      <b>VITON</b></p> <p><b>predisposizione per bloccastelo</b> <i>rod lock adaptor</i></p>
	10							
	25					X	X	
	50					X	X	
	80					X	X	
	100					X	X	
	125					X	X	
	160					X	X	
	200					X	X	
	250					X	X	
320					X	X		
<p><b>doppio effetto</b> <i>double acting</i> <b>non magnetico</b> <i>non-magnetic</i> <b>non ammortizzato</b> <i>without pneumatic cushioning</i> <b>stelo passante</b> <i>passing-through rod</i></p> 								<p><b>OPZIONI</b> <i>options</i></p> <p>Lo standard è evidenziato in grigio <i>The standard is marked with grey background</i></p> <p><b>materiale stelo</b> <i>[piston-rod material]</i></p> <p><b>INOX</b> <i>stainless steel</i></p> <p><b>materiale guarnizioni</b> <i>[seals material]</i></p> <p><b>NBR</b>      <b>VITON</b></p> <p><b>predisposizione per bloccastelo</b> <i>rod lock adaptor</i></p>
	10			X	X	X		
	25			X	X	X		
	50			X	X	X		
	80			X	X	X		
	100			X	X	X		
	125			X	X	X		
	160			X	X	X		
	200			X	X	X		
	250			X	X	X		
320			X	X	X			

4



## versioni disponibili

available versions

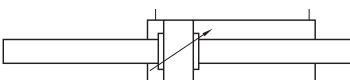
	alesaggio		10	12	16	20	25	
	corsa	bore						
	stroke							
<p><b>doppio effetto</b> <i>double acting</i> <b>magnetico</b> <i>magnetic</i> <b>non ammortizzato</b> <i>without pneumatic cushioning</i> <b>stelo passante</b> <i>passing-through rod</i></p> 	10				X	X	X	<p><b>OPZIONI</b> <i>options</i></p> <p>Lo standard è evidenziato in grigio <i>The standard is marked with grey background</i></p> <p><b>materiale stelo [piston-rod material]</b></p> <p><b>INOX</b> <i>stainless steel</i></p> <p><b>materiale guarnizioni [seals material]</b></p> <p><b>NBR</b>      <b>VITON</b></p> <p><b>predisposizione per bloccastelo</b> <i>rod lock adaptor</i></p>
	25				X	X	X	
	50				X	X	X	
	80				X	X	X	
	100				X	X	X	
	125				X	X	X	
	160				X	X	X	
	200				X	X	X	
	250				X	X	X	
	320				X	X	X	
<p><b>doppio effetto</b> <i>double acting</i> <b>non magnetico</b> <i>non-magnetic</i> <b>ammortizzato</b> <i>with pneumatic cushioning</i> <b>stelo passante</b> <i>passing-through rod</i></p> 	10							<p><b>OPZIONI</b> <i>options</i></p> <p>Lo standard è evidenziato in grigio <i>The standard is marked with grey background</i></p> <p><b>materiale stelo [piston-rod material]</b></p> <p><b>INOX</b> <i>stainless steel</i></p> <p><b>materiale guarnizioni [seals material]</b></p> <p><b>NBR</b>      <b>VITON</b></p> <p><b>predisposizione per bloccastelo</b> <i>rod lock adaptor</i></p>
	25					X	X	
	50					X	X	
	80					X	X	
	100					X	X	
	125					X	X	
	160					X	X	
	200					X	X	
	250					X	X	
	320					X	X	
<p><b>doppio effetto</b> <i>double acting</i> <b>magnetico</b> <i>magnetic</i> <b>ammortizzato</b> <i>with pneumatic cushioning</i> <b>stelo passante</b> <i>passing-through rod</i></p> 	10							<p><b>OPZIONI</b> <i>options</i></p> <p>Lo standard è evidenziato in grigio <i>The standard is marked with grey background</i></p> <p><b>materiale stelo [piston-rod material]</b></p> <p><b>INOX</b> <i>stainless steel</i></p> <p><b>materiale guarnizioni [seals material]</b></p> <p><b>NBR</b>      <b>VITON</b></p> <p><b>predisposizione per bloccastelo</b> <i>rod lock adaptor</i></p>
	25					X	X	
	50					X	X	
	80					X	X	
	100					X	X	
	125					X	X	
	160					X	X	
	200					X	X	
	250					X	X	
	320					X	X	

# microcilindri ISO 6432

minicylinders ISO 6432

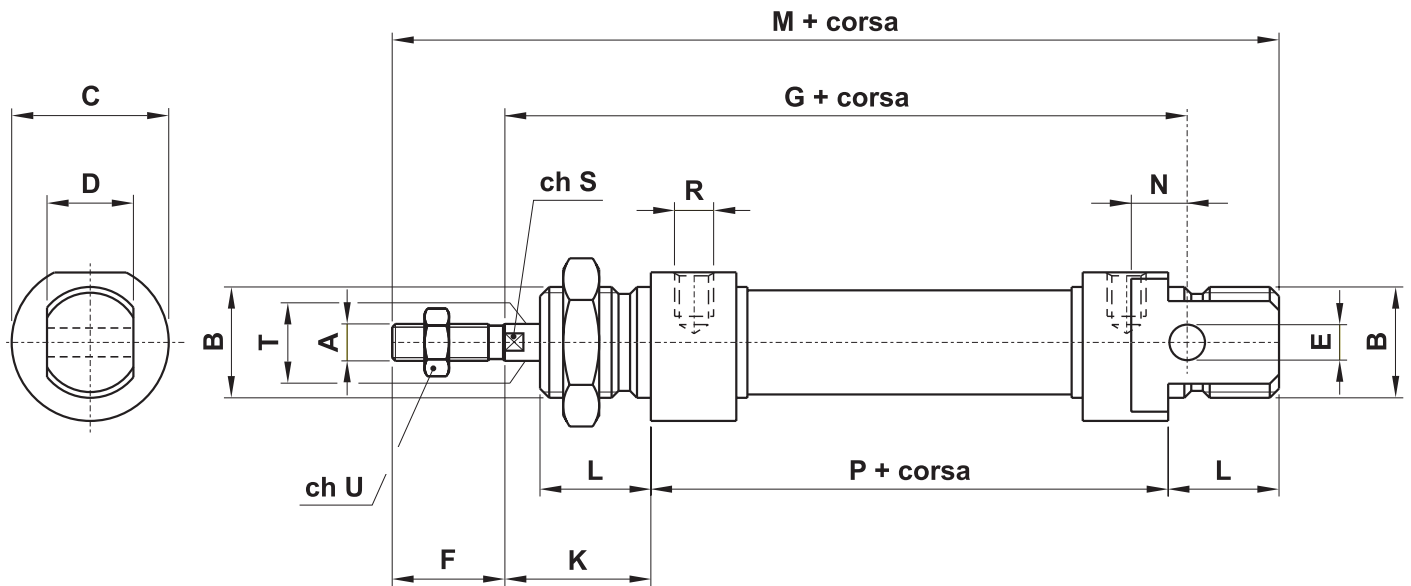

∅	A	B	C	D	E	F	G	K	L	M	N	P	R	S	T	U
10	M4	M12x1.25	∅16	8	∅4	12	64	16	12	86	6	46	M5	-	∅4	7
12	M6	M16x1.5	∅19	12	∅6	16	75	22	18	104	9	48	M5	5	∅6	10
16	M6	M16x1.5	∅19	12	∅6	16	82	22	18	109	9	53	M5	5	∅6	10
20	M8	M22x1.5	∅27	16	∅8	20	95	24	20	131	12	67	G1/8"	7	∅8	13
25	M10x1.25	M22x1.5	∅30	16	∅8	22	104	28	22	140	12	68	G1/8"	9	∅10	17

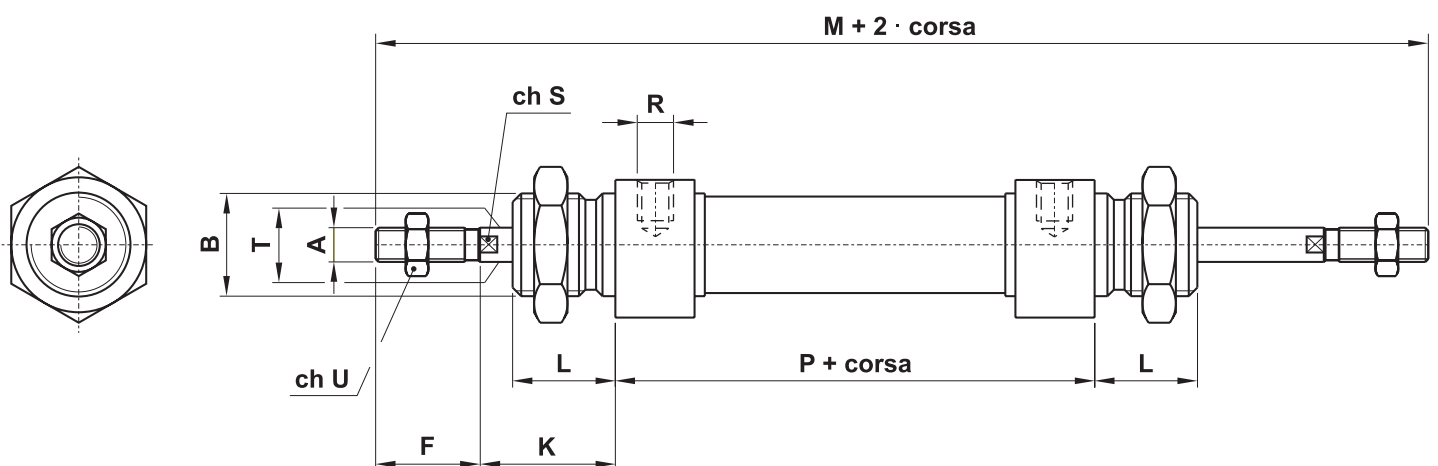

∅	A	B	F	K	L	M	P	R	S	T	U
16	M6	M16x1.5	16	22	18	129	53	M5	5	∅6	10
20	M8	M22x1.5	20	24	20	155	67	G1/8"	7	∅8	13
25	M10x1.25	M22x1.5	22	28	22	168	68	G1/8"	9	∅10	17

# fissaggi per microcilindri ISO 6432

fixing elements for minicylinders ISO 6432



## PIEDINO

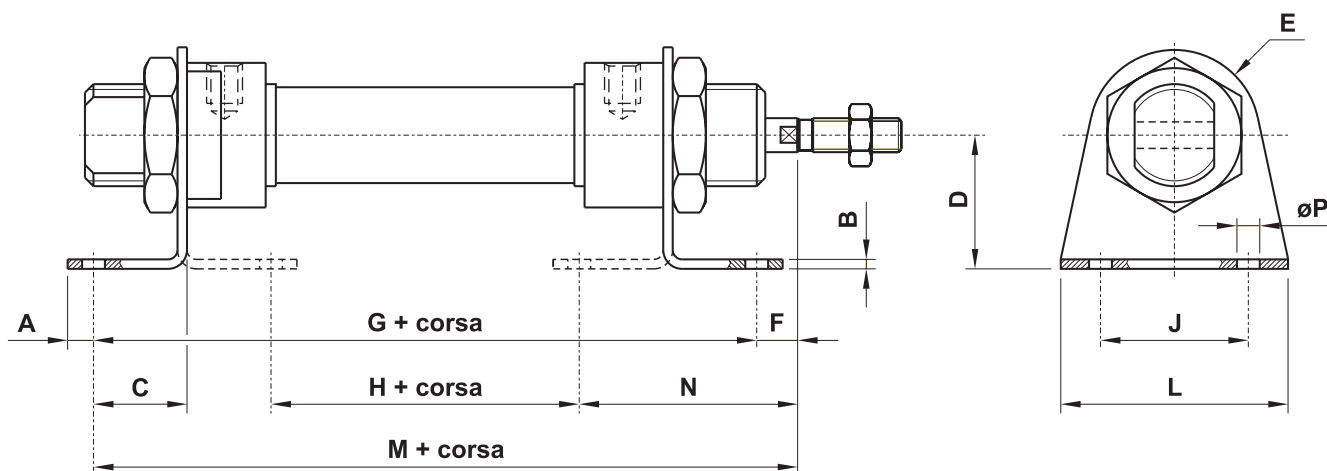

$\varnothing$	A	B	C	D	E	F	G	H	J	L	M	N	P
10	5	3	11	16	10	5	68	30	25	32	73	24	4.5
12	6	4	14	20	12.5	8	76	28	32	42	84	32	5.5
16	6	4	14	20	12.5	8	81	33	32	42	89	32	5.5
20	8	5	17	25	20	7	101	43	40	54	108	36	6.6
25	8	5	17	25	20	11	102	44	40	54	113	40	6.6

## FLANGIA

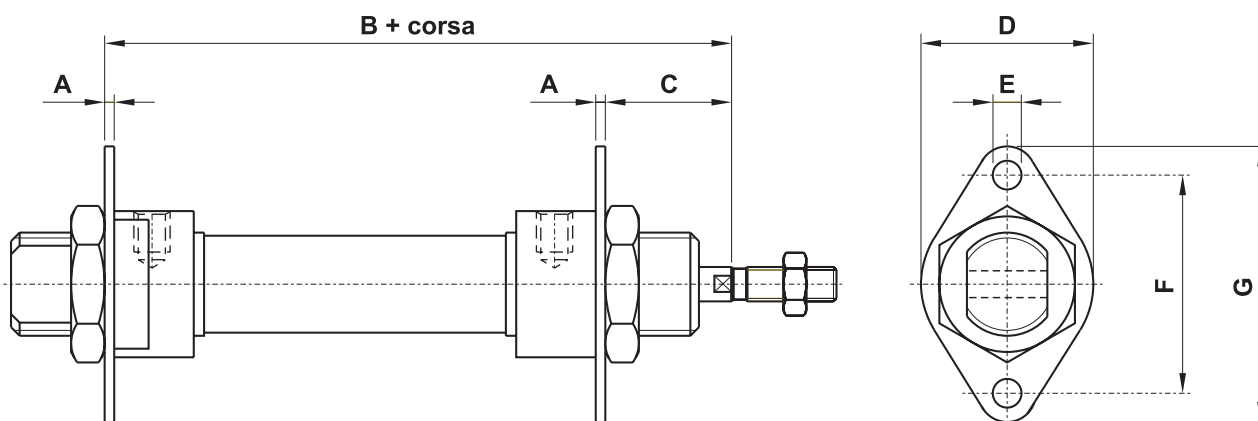

$\varnothing$	A	B	C	D	E	F	G
10	3	65	13	22	$\varnothing 4.5$	30	40
12	4	74	18	30	$\varnothing 5.5$	40	52
16	4	79	18	30	$\varnothing 5.5$	40	52
20	5	96	19	40	$\varnothing 6.6$	50	66
25	5	101	23	40	$\varnothing 6.6$	50	66

# fissaggi per microcilindri ISO 6432

fixing elements for minicylinders ISO 6432



## CONTROCERNIERA CON PERNO

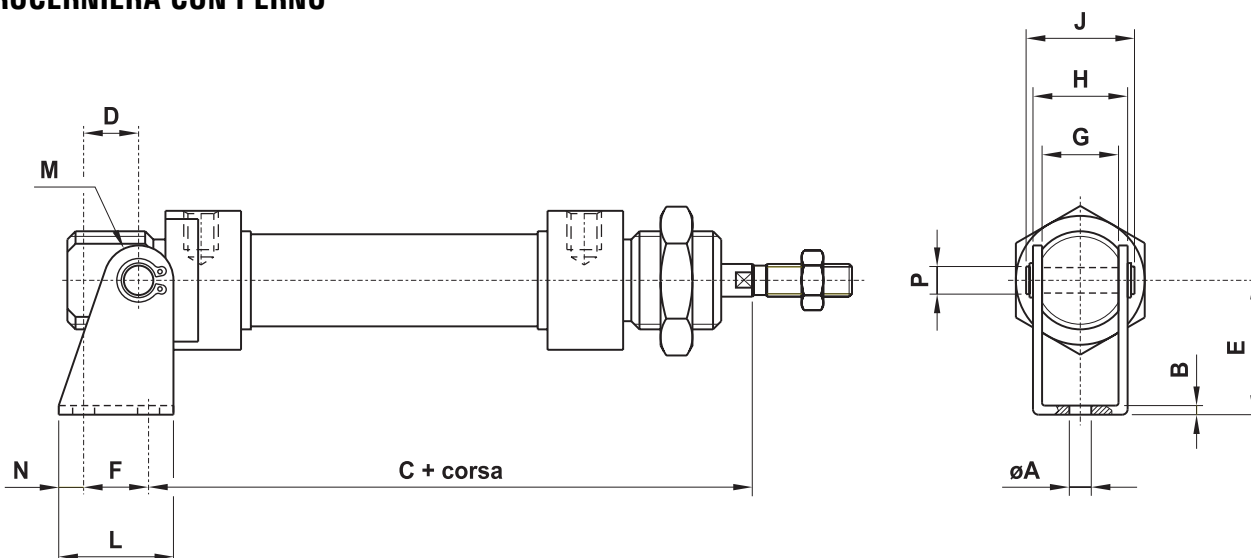

ø	A	B	C	D	E	F	G	H	J	L	M	N	P
10	4.5	2.5	62.5	12.25	24	12.5	8.1	13.1	17	22	5	4.75	ø4
12	5.5	3	73	13	27	15	12.1	18.1	23	25	7	5	ø6
16	5.5	3	80	13	27	15	12.1	18.1	23	25	7	5	ø6
20	6.6	4	91	16	30	20	16.1	24.1	30	32	10	6	ø8
25	6.6	4	100	16	30	20	16.1	24.1	30	32	10	6	ø8

## DADO PER TESTATA

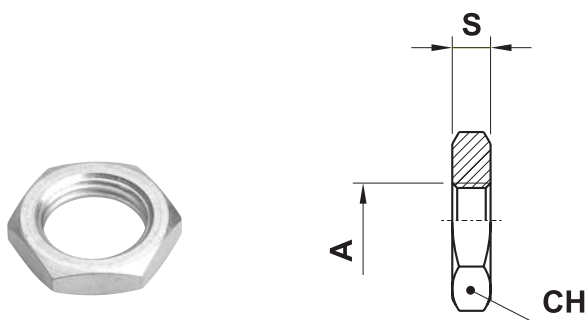

sigla part number	per alesaggio for bore	A	CH	S
GPM010	10	M12x1.25	19	6
GPM12-16	12-16	M16x1.5	22	8
GPM20-25	20-25	M22x1.5	27	8



## PIEDINO

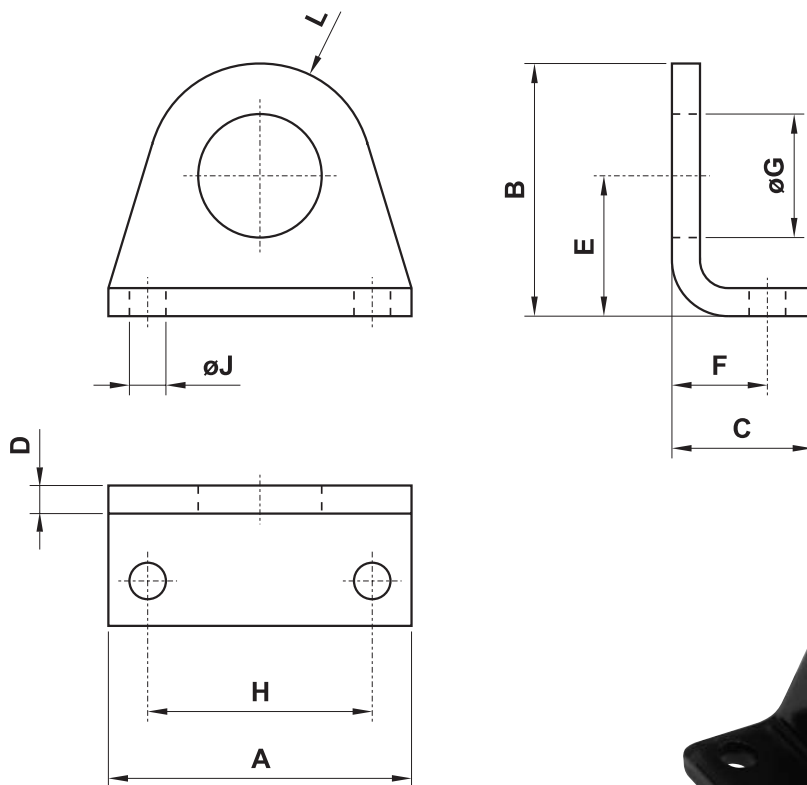

sigla* part number*	per alesaggio for bore	A	B	C	D	E	F	G	H	J	L
<b>PDMC08-10</b>	8-10	35	26	16	3	16	11	12	25	4.5	10
<b>PDMC12-16</b>	12-16	42	32.5	20	4	20	14	16	32	5.5	12.5
<b>PDMC20-25</b>	20-25	54	45	25	5	25	17	22	40	6.6	20

\* La sigla si riferisce a un solo piedino e non alla coppia

\* The part number is referred to only one element and not to the couple

## FLANGIA

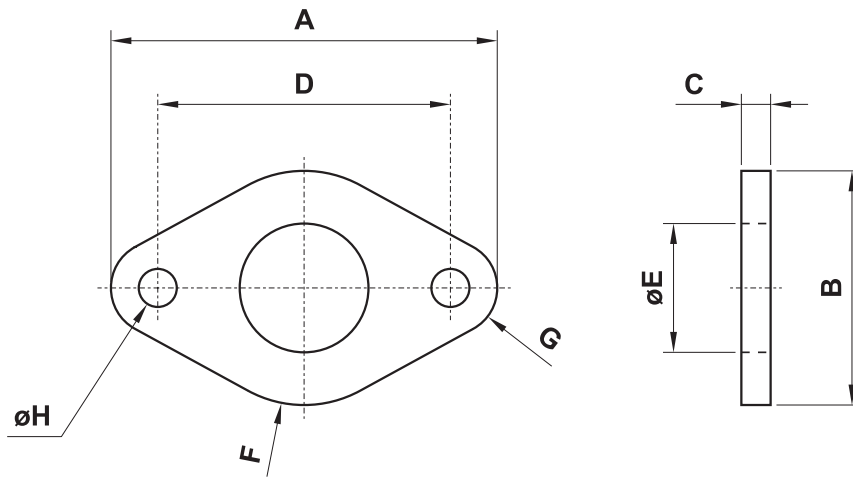

sigla part number	per alesaggio for bore	A	B	C	D	E	F	G	H
<b>FLMC08-10</b>	8-10	40	22	3	30	12	11	5	4.5
<b>FLMC12-16</b>	12-16	52	30	4	40	16	15	6	5.5
<b>FLMC20-25</b>	20-25	66	40	5	50	22	20	8	6.6

4

## CONTROCERNIERA CON PERNO

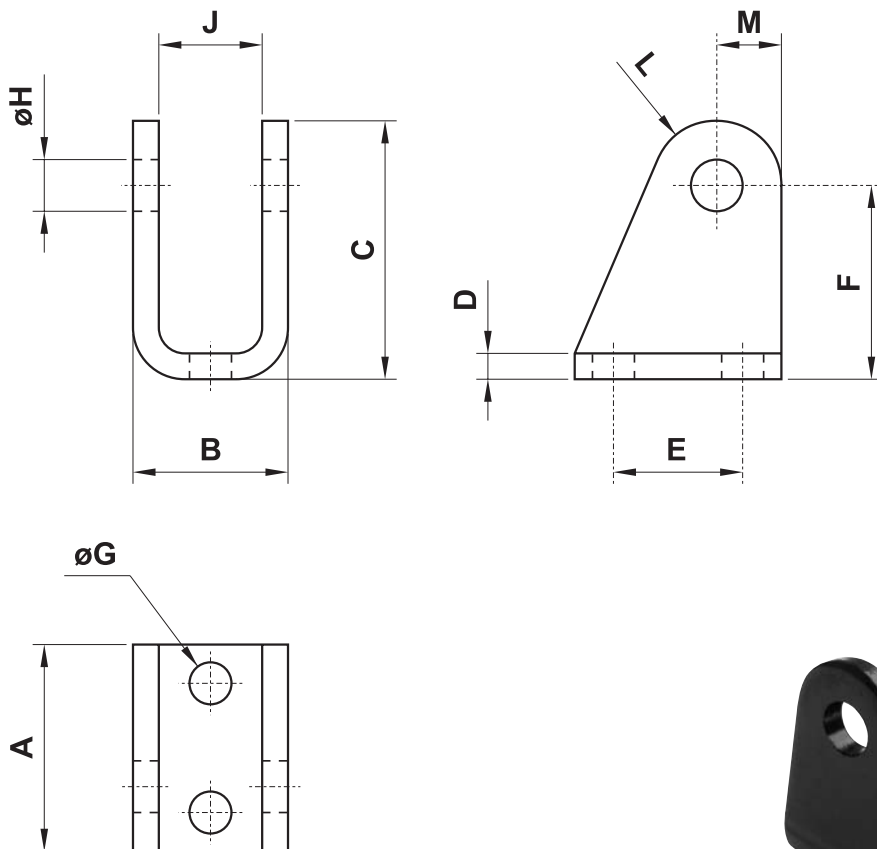

sigla part number	per alesaggio for bore	A	B	C	D	E	F	G	H	J	L	M
<b>CCMC08-10</b>	8-10	22	13.1	29	2.5	12.5	24	4.5	4	8.1	5	5
<b>CCMC12-16</b>	12-16	25	18.1	34	3	15	27	5.5	6	12.1	7	7
<b>CCMC20-25</b>	20-25	32	24.1	40	4	20	30	6.6	8	16.1	10	10

# cilindri a cartuccia

cartridge cylinders



- Cilindri a semplice effetto con molla anteriore  
*Single acting cylinders with front spring*
- Non magnetico  
*Non-magnetic*
- Versione con stelo filettato o non filettato  
*Version with threaded or non-threaded piston rod*
- Grande affidabilità e lunga durata  
*High reliability and long life time*

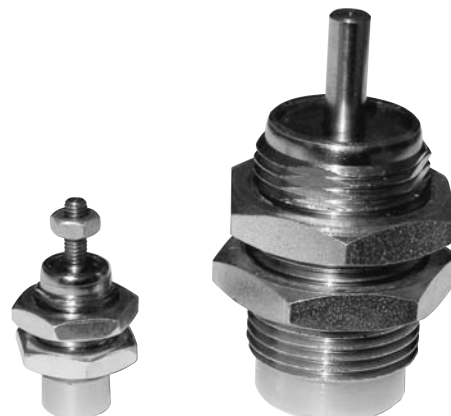

## Materiali

Camicia: ottone nichelato

Stelo: INOX

Dadi: acciaio zincato

Guarnizioni: poliuretano

Molla: acciaio

## Materials

Barrel: nickel plated brass

Piston-rod: stainless steel

Nuts: zinc coated steel

Sealings: polyurethane

Spring: steel

## AVVERTENZE - WARNING

- Evitare carichi radiali sullo stelo  
*Avoid side loads on the piston rod*

- Evitare di caricare lo stelo quando viene richiamato dalla molla  
*Do not load the piston rod during the spring retraction*

Pressione di esercizio <i>Working pressure</i>	2 ... 7 bar 0.2 ... 0.7 MPa
Temperatura di esercizio <i>Temperature range</i>	max +60°C
Alesaggi <i>Bores</i>	6; 10; 16 mm
Corse <i>Strokes</i>	5; 10; 15 mm
Fluido <i>Fluid</i>	Aria filtrata 50µ con o senza lubrificazione <i>50µ filtered, lubricated or non lubricated air</i>

# cilindri a cartuccia

cartridge cylinders

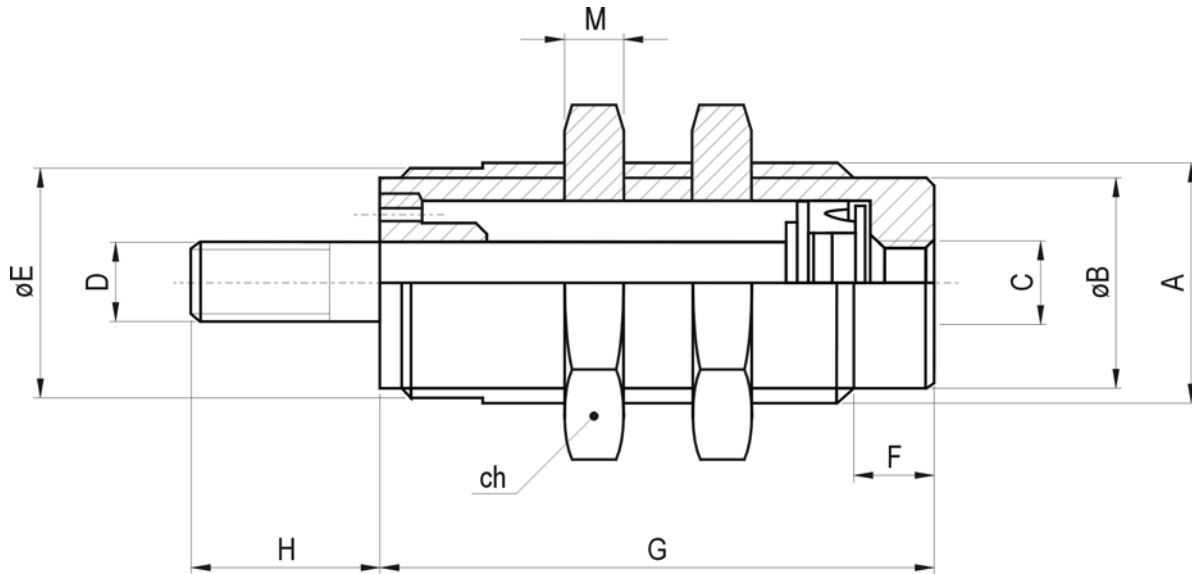

alesaggio bore	A	B	C	D		øE	F	H	M	ch	G		
				con stelo filettato threaded piston rod	con stelo non filettato non-threaded piston rod						corsa cilindro [cyl. stroke]		
6	M10x1	8.5	M5	M3	ø3	9	5	8	3	14	5	10	15
10	M15x1.5	13	M5	M4	ø5	14	5	11.5	4	19	20.5	27	34
16	M22x1.5	19	M5	M5	ø5	20	6	14	5	27	23.5	29.5	36

## FORZE a 6 bar - forces at 6 bar

alesaggio bore	forza in spinta press force	forza di ritorno della molla return spring force	
		corsa 0 [stroke 0]	fondo corsa [stroke end]
6	12 N	1.2 N	3.8 N
10	35 N	2.7 N	7.3 N
16	101 N	3.3 N	6.6 N

## PESI - weights

alesaggio bore	corsa cilindro [cyl. stroke]		
	5	10	15
6	10 g	13 g	15 g
10	27 g	32 g	36 g
16	71 g	78 g	87 g

## CODICI DI ORDINAZIONE - order codes

cilindri con stelo filettato - cylinders with threaded piston rod			
alesaggio bore	corsa - stroke		
	5	10	15
6	20.100.4	20.101.4	20.102.4
10	20.103.4	20.104.4	20.105.4
16	20.106.4	20.107.4	20.108.4

cilindri con stelo non filettato - cylinders with non-threaded piston rod			
alesaggio bore	corsa - stroke		
	5	10	15
6	20.109.4	20.110.4	20.111.4
10	20.112.4	20.113.4	20.114.4
16	20.115.4	20.116.4	20.117.4

# cilindri tondi

round cylinders



- Valida alternativa alle esecuzioni tradizionali  
*Up-to-date alternative to traditional versions*
- Grande affidabilità e lunga durata  
*High reliability and long life time*
- Versione magnetica standard  
*Standard magnetic version*
- Esecuzioni speciali a richiesta  
*Special versions on request*



## Materiali

Camicia: alluminio

Stelo: C45 cromato o INOX

Testate: alluminio

Pistone: alluminio

Guarnizioni: NBR o VITON

Magnete: plastoferrite

Guida pistone: teflon PTFE

## Materials

Barrel: aluminium

Piston-rod: C45 (chromium plated) or stainless steel

End-cups: aluminium

Piston: aluminium

Sealings: NBR or VITON

Magnet: magnetic iron compound

Piston guide ring: teflon PTFE

Pressione di esercizio <i>Working pressure</i>	max 10 bar max 1 MPa
Temperatura di esercizio <i>Temperature range</i>	max +60°C
Alesaggi <i>Bores</i>	32; 40; 50 mm
Corse <i>Strokes</i>	25 ... 500 mm
Fluido <i>Fluid</i>	Aria filtrata 50µ con o senza lubrificazione <i>50µ filtered, lubricated or non lubricated air</i>

## chiave di codifica

key to codes

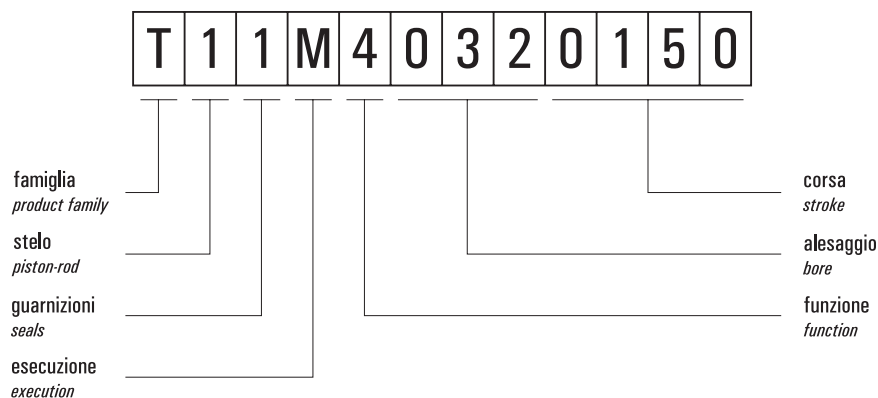

### Famiglia *[product family]*

**T** cilindri tondi *[round cylinders]*

### Stelo *[piston-rod]*

**1** C45 cromato *[C45 chromium plated]*

**2** INOX *[stainless steel]*

### Guarnizioni *[seals]*

**1** NBR

**2** tutte le guarnizioni in VITON *[all seals in VITON]*

**3** guarnizioni dello stelo in VITON *[rod seals in VITON]*

### Esecuzione *[execution]*

**M** magnetico *[magnetic]*

### Funzione *[function]*

**2** doppio effetto non ammortizzato

*[double acting without pneumatic cushioning]*

**3** doppio effetto ammortizzato

*[double acting with pneumatic cushioning]*

**4** doppio effetto non ammortizzato stelo passante

*[double acting without pneumatic cushioning, with passing-through rod]*

**5** doppio effetto ammortizzato stelo passante

*[double acting with pneumatic cushioning, with passing-through rod]*

## versioni disponibili

available versions

<b>doppio effetto</b> <i>double acting</i> <b>magnetico</b> <i>magnetic</i> <b>non ammortizzato</b> <i>without pneumatic cushioning</i>	alesaggio		32	40	50	<b>OPZIONI</b> <i>options</i>  Lo standard è evidenziato in grigio <i>The standard is marked with grey background</i>					
	corsa	bore									
	25	stroke	X	X	X	<b>materiale stelo [piston-rod material]</b>  <table border="1"> <tr> <td>C45 cromato <i>C45 chromium plated</i></td> <td>INOX <i>stainless steel</i></td> </tr> </table> <b>materiale guarnizioni [seals material]</b>  <table border="1"> <tr> <td>NBR</td> <td>tutte in VITON <i>all seals in VITON</i></td> <td>guarnizioni stelo in VITON <i>rod seals in VITON</i></td> </tr> </table>	C45 cromato <i>C45 chromium plated</i>	INOX <i>stainless steel</i>	NBR	tutte in VITON <i>all seals in VITON</i>	guarnizioni stelo in VITON <i>rod seals in VITON</i>
	C45 cromato <i>C45 chromium plated</i>	INOX <i>stainless steel</i>									
	NBR	tutte in VITON <i>all seals in VITON</i>	guarnizioni stelo in VITON <i>rod seals in VITON</i>								
	50		X	X	X						
	75		X	X	X						
	80		X	X	X						
	100		X	X	X						
	125		X	X	X						
	150		X	X	X						
	160		X	X	X						
	200		X	X	X						
	250		X	X	X						
	300		X	X	X						
	320		X	X	X						
400		X	X	X							
500		X	X	X							
<b>doppio effetto</b> <i>double acting</i> <b>magnetico</b> <i>magnetic</i> <b>non ammortizzato</b> <i>without pneumatic cushioning</i> <b>stelo passante</b> <i>passing-through rod</i>	alesaggio		32	40	50	<b>OPZIONI</b> <i>options</i>  Lo standard è evidenziato in grigio <i>The standard is marked with grey background</i>					
	corsa	bore									
	25	stroke	X	X	X	<b>materiale stelo [piston-rod material]</b>  <table border="1"> <tr> <td>C45 cromato <i>C45 chromium plated</i></td> <td>INOX <i>stainless steel</i></td> </tr> </table> <b>materiale guarnizioni [seals material]</b>  <table border="1"> <tr> <td>NBR</td> <td>tutte in VITON <i>all seals in VITON</i></td> <td>guarnizioni stelo in VITON <i>rod seals in VITON</i></td> </tr> </table>	C45 cromato <i>C45 chromium plated</i>	INOX <i>stainless steel</i>	NBR	tutte in VITON <i>all seals in VITON</i>	guarnizioni stelo in VITON <i>rod seals in VITON</i>
	C45 cromato <i>C45 chromium plated</i>	INOX <i>stainless steel</i>									
	NBR	tutte in VITON <i>all seals in VITON</i>	guarnizioni stelo in VITON <i>rod seals in VITON</i>								
	50		X	X	X						
	75		X	X	X						
	80		X	X	X						
	100		X	X	X						
	125		X	X	X						
	150		X	X	X						
	160		X	X	X						
	200		X	X	X						
	250		X	X	X						
	300		X	X	X						
	320		X	X	X						
400		X	X	X							
500		X	X	X							

4



## versioni disponibili

available versions

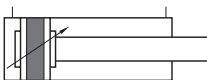
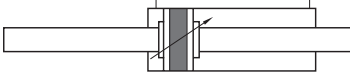
<b>doppio effetto</b> <i>double acting</i> <b>magnetico</b> <i>magnetic</i> <b>ammortizzato</b> <i>with pneumatic cushioning</i>	alesaggio		32	40	50	<b>OPZIONI</b> <i>options</i>  Lo standard è evidenziato in grigio <i>The standard is marked with grey background</i>					
	corsa	bore									
	25		X	X	X	<b>materiale stelo [piston-rod material]</b>  <table border="1"> <tr> <td>C45 cromato <i>C45 chromium plated</i></td> <td>INOX <i>stainless steel</i></td> </tr> </table> <b>materiale guarnizioni [seals material]</b>  <table border="1"> <tr> <td>NBR</td> <td>tutte in VITON <i>all seals in VITON</i></td> <td>guarnizioni stelo in VITON <i>rod seals in VITON</i></td> </tr> </table>	C45 cromato <i>C45 chromium plated</i>	INOX <i>stainless steel</i>	NBR	tutte in VITON <i>all seals in VITON</i>	guarnizioni stelo in VITON <i>rod seals in VITON</i>
	C45 cromato <i>C45 chromium plated</i>	INOX <i>stainless steel</i>									
	NBR	tutte in VITON <i>all seals in VITON</i>	guarnizioni stelo in VITON <i>rod seals in VITON</i>								
	50		X	X	X						
	75		X	X	X						
	80		X	X	X						
	100		X	X	X						
	125		X	X	X						
	150		X	X	X						
	160		X	X	X						
	200		X	X	X						
	250		X	X	X						
	300		X	X	X						
	320		X	X	X						
	400		X	X	X						
500		X	X	X							
<b>doppio effetto</b> <i>double acting</i> <b>magnetico</b> <i>magnetic</i> <b>ammortizzato</b> <i>with pneumatic cushioning</i> <b>stelo passante</b> <i>passing-through rod</i>	alesaggio		32	40	50	<b>OPZIONI</b> <i>options</i>  Lo standard è evidenziato in grigio <i>The standard is marked with grey background</i>					
	corsa	bore									
	25		X	X	X	<b>materiale stelo [piston-rod material]</b>  <table border="1"> <tr> <td>C45 cromato <i>C45 chromium plated</i></td> <td>INOX <i>stainless steel</i></td> </tr> </table> <b>materiale guarnizioni [seals material]</b>  <table border="1"> <tr> <td>NBR</td> <td>tutte in VITON <i>all seals in VITON</i></td> <td>guarnizioni stelo in VITON <i>rod seals in VITON</i></td> </tr> </table>	C45 cromato <i>C45 chromium plated</i>	INOX <i>stainless steel</i>	NBR	tutte in VITON <i>all seals in VITON</i>	guarnizioni stelo in VITON <i>rod seals in VITON</i>
	C45 cromato <i>C45 chromium plated</i>	INOX <i>stainless steel</i>									
	NBR	tutte in VITON <i>all seals in VITON</i>	guarnizioni stelo in VITON <i>rod seals in VITON</i>								
	50		X	X	X						
	75		X	X	X						
	80		X	X	X						
	100		X	X	X						
	125		X	X	X						
	150		X	X	X						
	160		X	X	X						
	200		X	X	X						
	250		X	X	X						
	300		X	X	X						
	320		X	X	X						
	400		X	X	X						
500		X	X	X							

# cilindri tondi

round cylinders

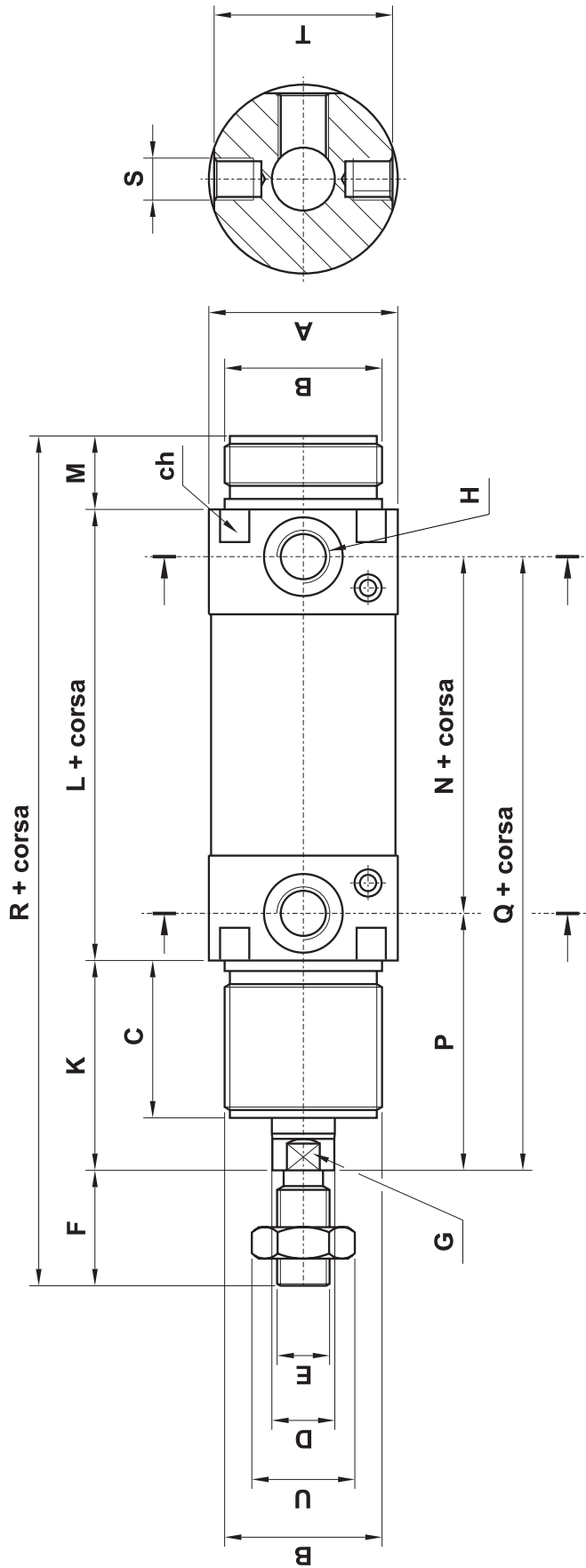

Ø	A	B	C	D	E	F	G	H	ch	K	L	M	N	P	Q	R	S	T	U
32	Ø38	M30x1.5	30	Ø12	M10x1.25	20	CH 10	G1/8"	36	38	96	14	78	47	125	168	M8x1	35	CH 17
40	Ø46	M38x1.5	35	Ø16	M12x1.25	24	CH 13	G1/4"	45	45	113	16	89	57	146	198	M10x1	42	CH 19
50	Ø57	M45x1.5	38	Ø20	M16x1.5	32	CH 17	G1/4"	55	50	120	18	96	62	158	220	M12x1.5	53	CH 24

4

# cilindri tondi

round cylinders



## VERSIONE STELO PASSANTE

Version with passing-through rod

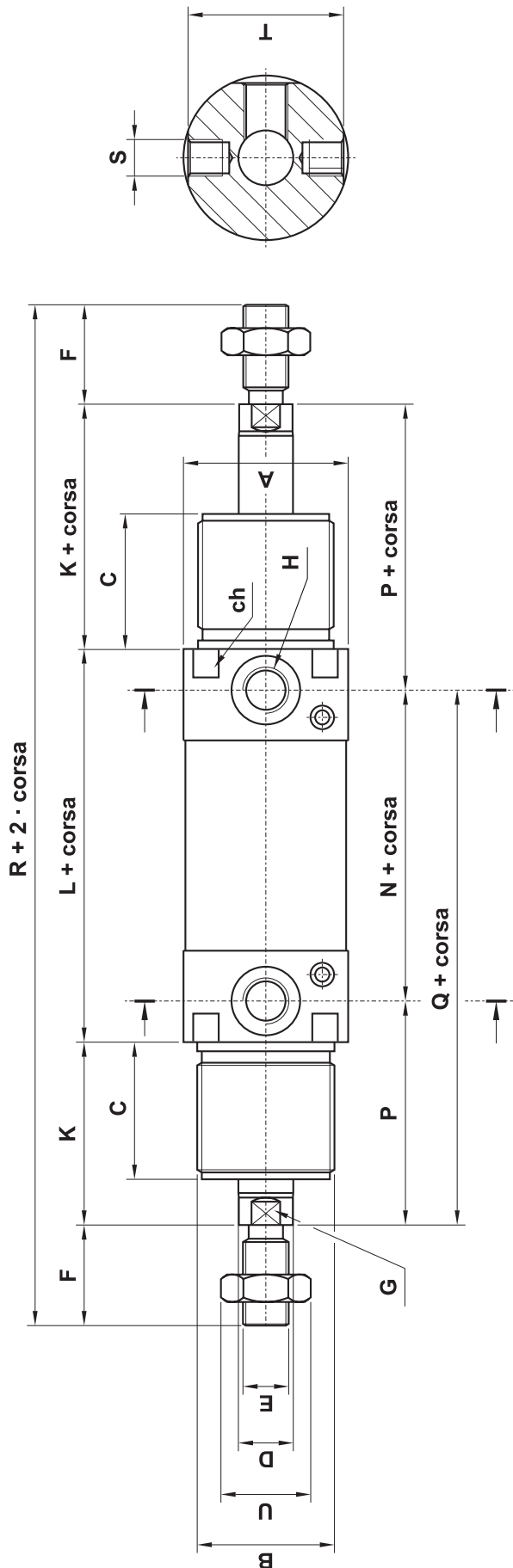

Ø	A	B	C	D	E	F	G	H	ch	K	L	N	P	Q	R	S	T	U
32	ø38	M30x1.5	30	ø12	M10x1.25	20	CH 10	G1/8"	36	38	96	78	47	125	212	M8x1	35	CH 17
40	ø46	M38x1.5	35	ø16	M12x1.25	24	CH 13	G1/4"	45	45	113	89	57	146	251	M10x1	42	CH 19
50	ø57	M45x1.5	38	ø20	M16x1.5	32	CH 17	G1/4"	55	50	120	96	62	158	284	M12x1.5	53	CH 24

## kit guarnizioni di ricambio

seals kit

### NBR - MAGNETICO

non ammortizzato			ammortizzato		
per alesaggio for bore	sigla part number	codice code	per alesaggio for bore	sigla part number	codice code
32	<b>SGT032</b>	26.192.2N	32	<b>SGT032A</b>	26.430.2
40	<b>SGT040</b>	26.193.2N	40	<b>SGT040A</b>	26.431.2
50	<b>SGT050</b>	26.194.2N	50	<b>SGT050A</b>	26.432.2

### VITON - MAGNETICO

non ammortizzato			ammortizzato		
per alesaggio for bore	sigla part number	codice code	per alesaggio for bore	sigla part number	codice code
32	<b>SGT032V</b>	26.360.2N	32	<b>SGT032AV</b>	26.433.2
40	<b>SGT040V</b>	26.361.2N	40	<b>SGT040AV</b>	26.434.2
50	<b>SGT050V</b>	26.362.2N	50	<b>SGT050AV</b>	26.435.2

# fissaggi per cilindri tondi

fixing elements for round cylinders



## GHIERA

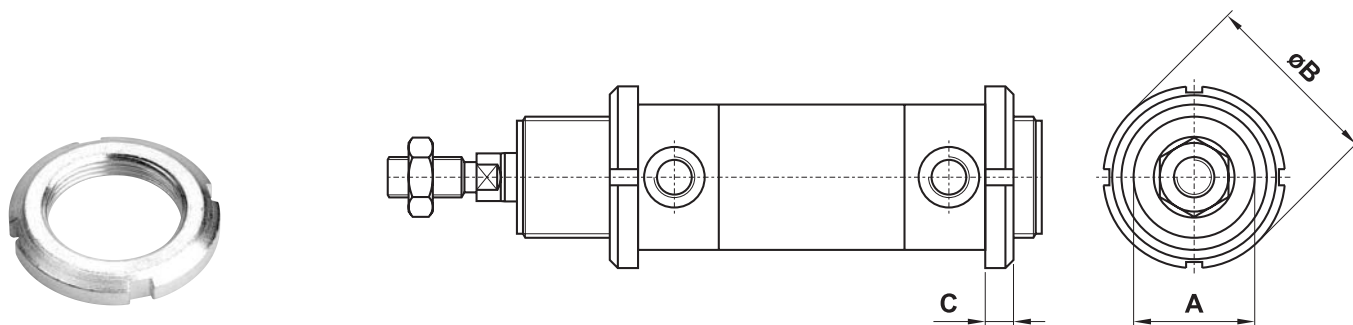

sigla part number	per alesaggio for bore	A	B	C
<b>GPT032</b>	32	M30x1.5	45	7
<b>GPT040</b>	40	M38x1.5	50	8
<b>GPT050</b>	50	M45x1.5	58	9

## CONTROCERNIERA CON PERNO

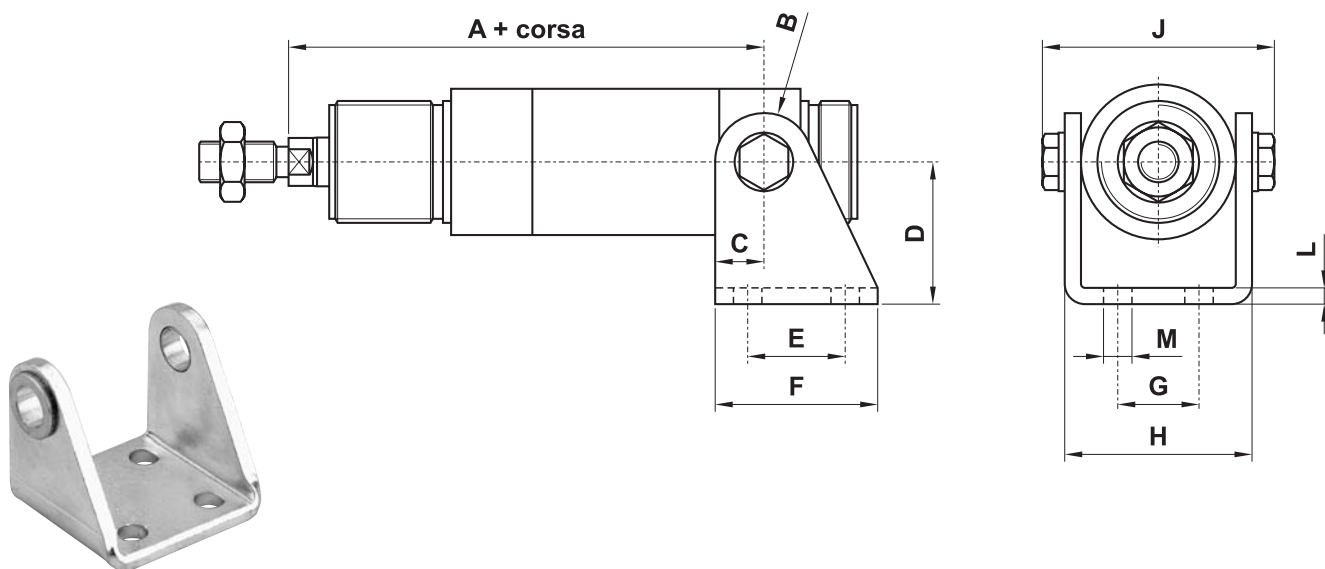

sigla part number	per alesaggio for bore	A	B	C	D	E	F	G	H	J	L	M
<b>CCR032</b>	32	125	12	12	35	24	40	20	46.1	58	4	ø7
<b>CCR040</b>	40	146	13	13	40	30	50	28	56.1	70	5	ø9
<b>CCR050</b>	50	158	14	14	45	34	54	36	69.1	86	6	ø9

# fissaggi per cilindri tondi

fixing elements for round cylinders



## PIEDINO

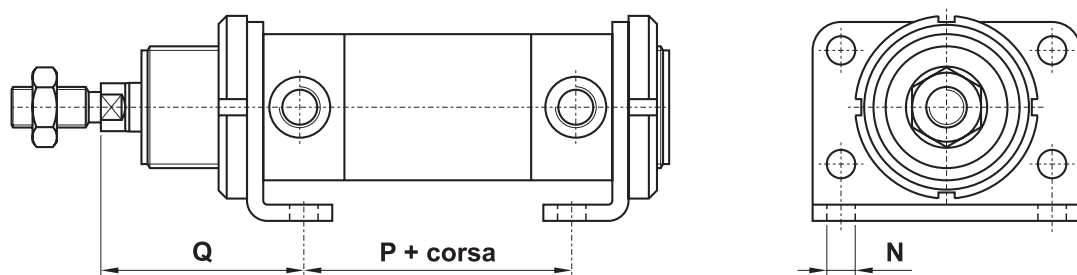
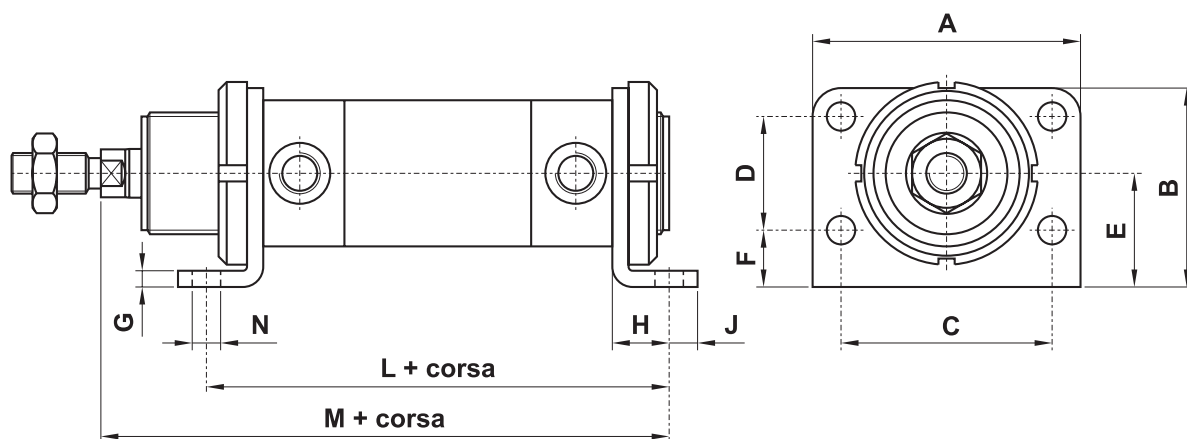

sigla* part number*	per alesaggio for bore	A	B	C	D	E	F	G	H	J	L	M	N	P	Q
FPT032	32	66	49	52	28	28	14	4	14	7	124	148	ø7	76	48
FPT040	40	80	58	60	30	33	18	5	20	10	153	178	ø9	83	60
FPT050	50	90	70	70	40	40	20	6	20	10	160	190	ø9	92	64

\* La sigla si riferisce a un solo piedino e non alla coppia

\* The part number is referred to only one element and not to the couple

## CERNIERA MASCHIO SNODO SFERICO

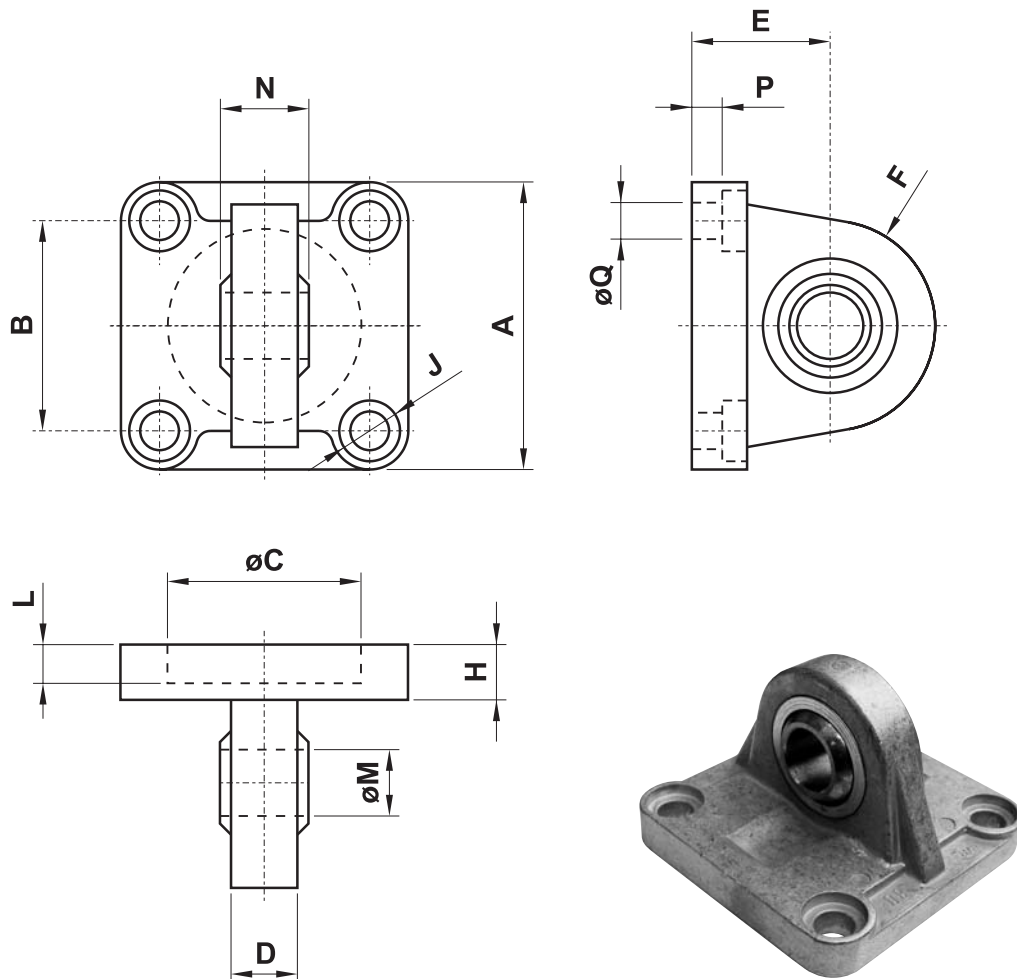

sigla part number	per alesaggio for bore	A	B	C	D	E	F	H	J	L	M	N	P	Q
CMSS032	32	45	32.5	30	10.5	22	16	9	ø11	5	10	14	5.5	6.6
CMSS040	40	52	38	35	12	25	19	9	ø11	5	12	16	5.5	6.6
CMSS050	50	65	46.5	40	15	27	21	11	ø15	5	16	21	6.5	9
CMSS063	63	75	56.5	45	15	32	24	11	ø15	5	16	21	6.5	9
CMSS080	80	95	72	45	18	36	28.5	14	ø18	5	20	25	10	11
CMSS100	100	115	89	55	18	41	30	14	ø18	5	20	25	10	11
CMSS125	125	140	110	60	25	50	40	20	ø20	7	30	37	10	13.5
CMSS160	160	180	140	65	28	55	45	20	ø26	7	35	43	10	18
CMSS200	200	220	175	75	28	60	48	25	ø26	7	35	43	11	18

## CERNIERA MASCHIO

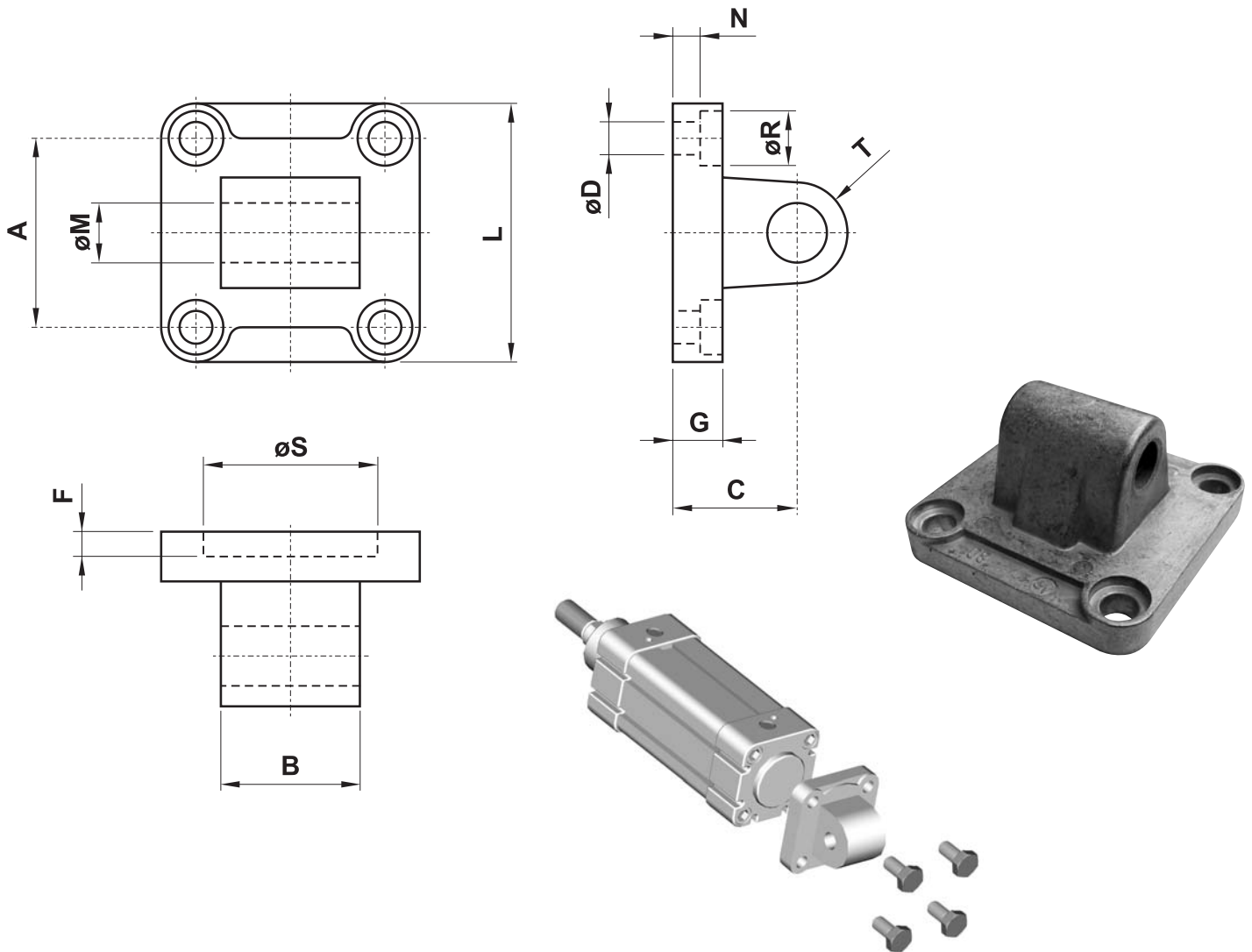

sigla part number	sigla part number	per alesaggio for bore	A	B	C	D	F	G	L	M	N	R	S	T
standard	con boccola di bronzo													
<b>CMIS032</b>	<b>CMKS032</b>	32	32.5	26	22	6.6	5	9	45	10	5.5	11	30	10
<b>CMIS040</b>	<b>CMKS040</b>	40	38	28	25	6.6	5	9	52	12	5.5	11	35	12
<b>CMIS050</b>	<b>CMKS050</b>	50	46.5	32	27	9	5	11	65	12	6.5	15	40	12
<b>CMIS063</b>	<b>CMKS063</b>	63	56.5	40	32	9	5	11	75	16	6.5	15	45	16
<b>CMIS080</b>	<b>CMKS080</b>	80	72	50	36	11	5	14	95	16	10	18	45	16
<b>CMIS100</b>	<b>CMKS100</b>	100	89	60	41	11	5	14	115	20	10	18	55	20
<b>CMIS125</b>	<b>CMKS125</b>	125	110	70	50	14	7	20	140	25	10	20	60	25
<b>CMIS160</b>	<b>CMKS160</b>	160	140	90	55	18	7	20	180	30	10	26	65	25
<b>CMIS200</b>	<b>CMKS200</b>	200	175	90	60	18	7	25	220	30	11	26	75	25



## CERNIERA FEMMINA CON PERNO

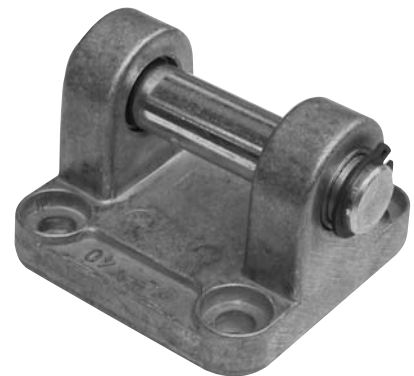
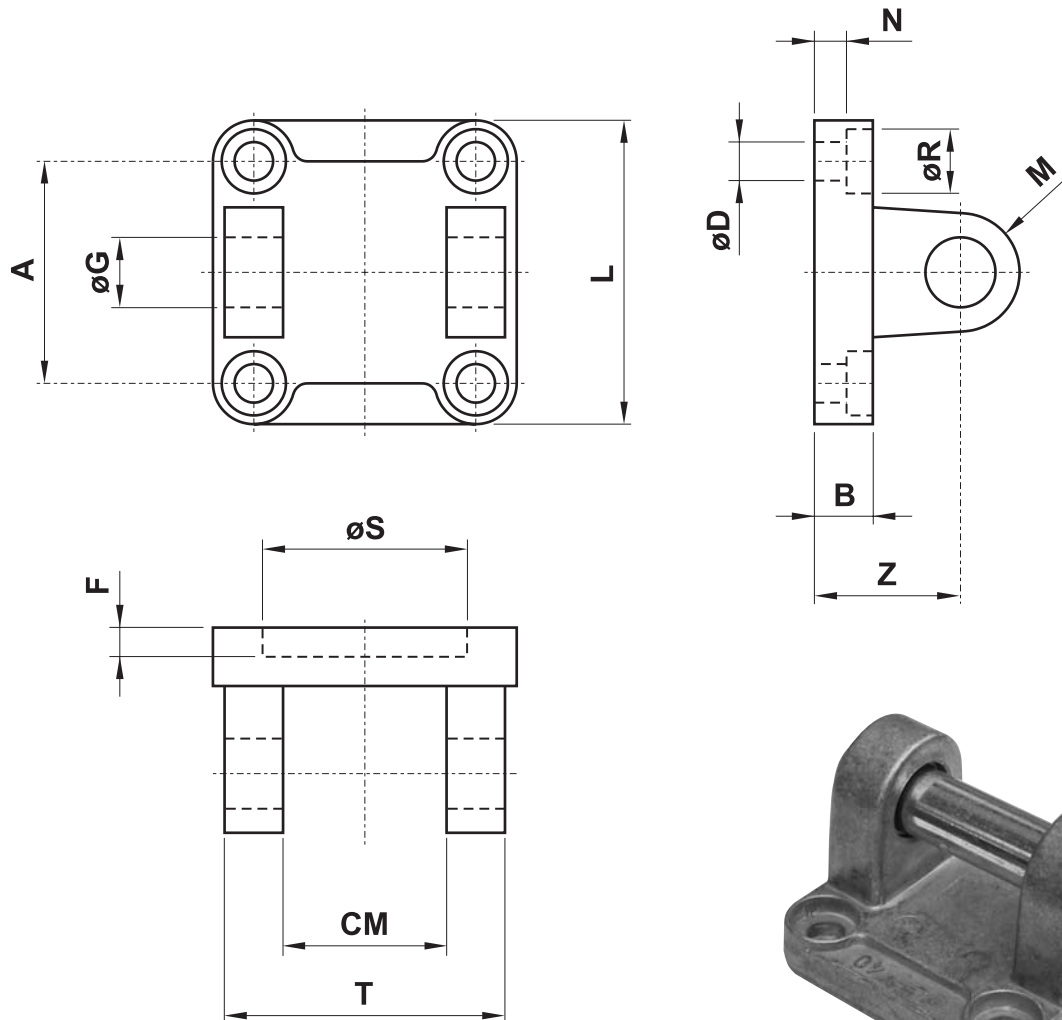

sigla part number	sigla part number	per alesaggio for bore	A	B	CM	D	F	G	L	M	N	R	S	T	Z
standard	con boccola di bronzo														
<b>CFIS032</b>	<b>CFKS032</b>	32	32.5	9	26	6.6	5	10	45	10	5.5	11	30	45	22
<b>CFIS040</b>	<b>CFKS040</b>	40	38	9	28	6.6	5	12	52	12	5.5	11	35	52	25
<b>CFIS050</b>	<b>CFKS050</b>	50	46.5	11	32	9	5	12	65	12	6.5	15	40	60	27
<b>CFIS063</b>	<b>CFKS063</b>	63	56.5	11	40	9	5	16	75	16	6.5	15	45	70	32
<b>CFIS080</b>	<b>CFKS080</b>	80	72	14	50	11	5	16	95	16	10	18	45	90	36
<b>CFIS100</b>	<b>CFKS100</b>	100	89	14	60	11	5	20	115	20	10	18	55	110	41
<b>CFIS125</b>	<b>CFKS125</b>	125	110	20	70	14	7	25	140	25	10	20	60	130	50
<b>CFIS160</b>	<b>CFKS160</b>	160	140	20	90	18	7	30	180	25	10	26	65	170	55
<b>CFIS200</b>	<b>CFKS200</b>	200	175	25	90	18	7	30	220	25	11	26	75	170	60

## FLANGIA

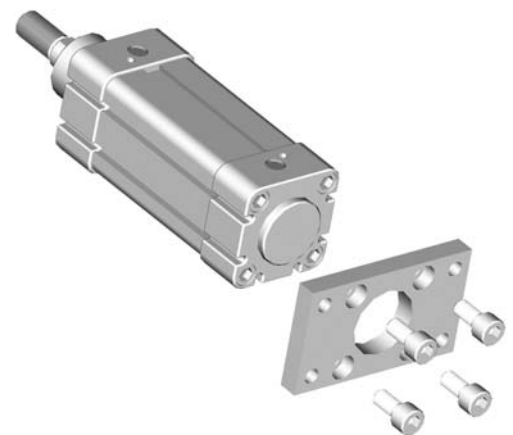
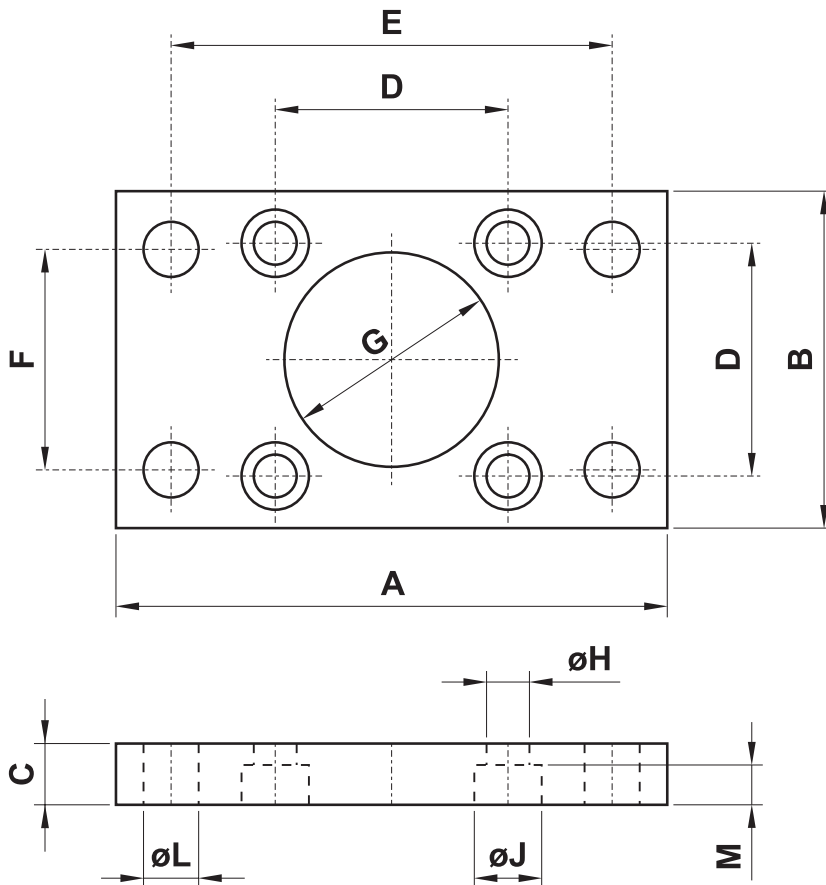

sigla part number	per alesaggio for bore	A	B	C	D	E	F	G	H	J	L	M
<b>FLIS032</b>	32	80	45	10	32.5	64	32	ø30	6.6	10.5	7	6.5
<b>FLIS040</b>	40	90	52	10	38	72	36	ø35	6.6	11	9	6.5
<b>FLIS050</b>	50	110	65	12	46.5	90	45	ø40	9	15	9	8.5
<b>FLIS063</b>	63	120	75	12	56.5	100	50	ø45	9	15	9	8.5
<b>FLIS080</b>	80	150	95	16	72	126	63	ø45	11	18	12	10.5
<b>FLIS100</b>	100	170	115	16	89	150	75	ø55	11	18	14	10.5
<b>FLIS125</b>	125	205	140	20	110	180	90	ø60	13.5	20	16	12.5
<b>FLIS160</b>	160	260	180	20	140	230	115	ø65	18	26	18	16.5
<b>FLIS200</b>	200	300	220	25	175	270	135	ø75	18	26	22	16.5

## PIEDINO

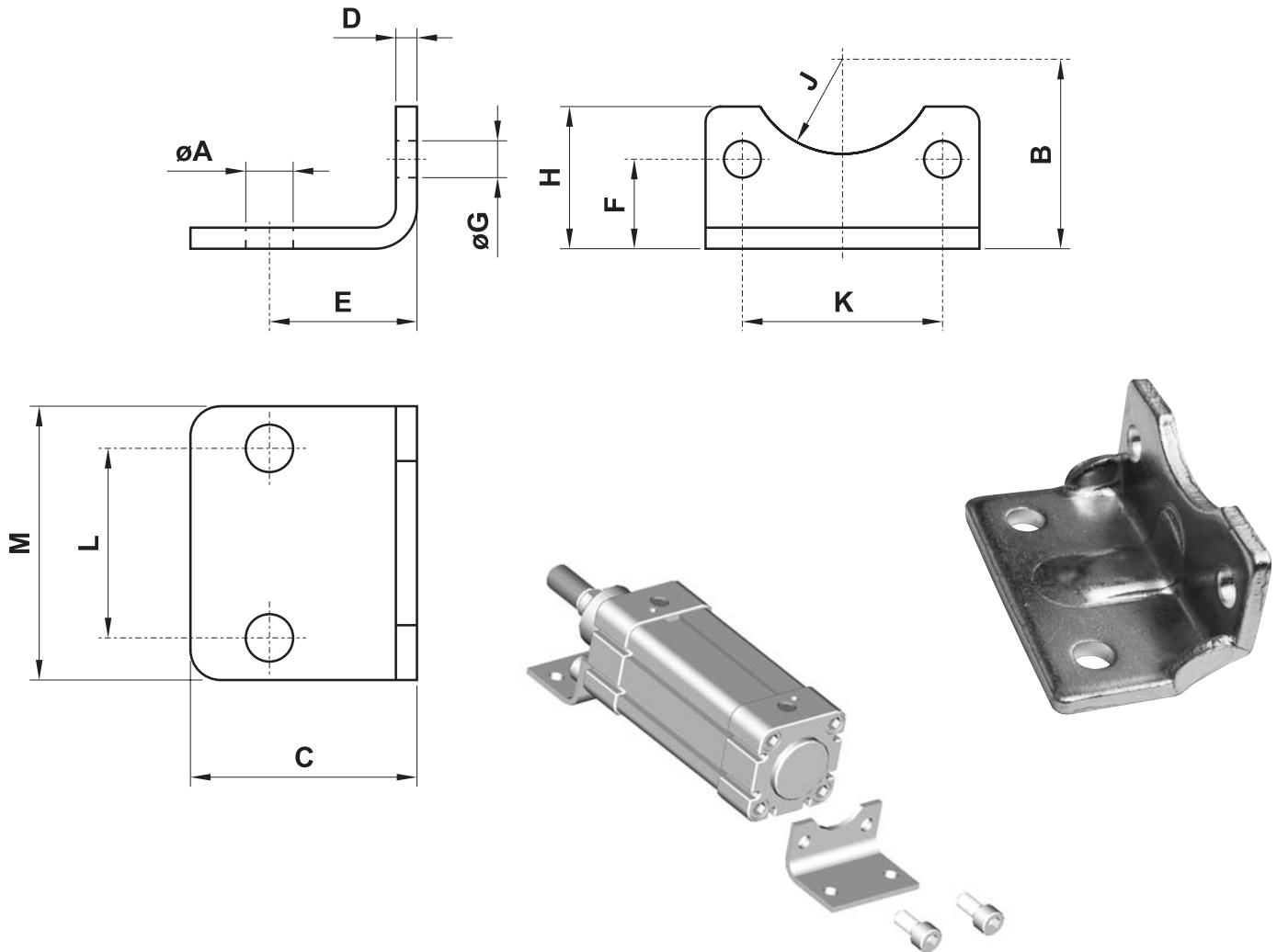

sigla* part number*	per alesaggio for bore	A	B	C	D	E	F	G	H	J	K	L	M
<b>PBIS032</b>	32	7	32	35	4	24	15.75	7	30	15	32.5	32	45
<b>PBIS040</b>	40	9	36	36	4	28	17	7	30	17.5	38	36	52
<b>PBIS050</b>	50	9	45	47	5	32	21.75	9	36	20	46.5	45	65
<b>PBIS063</b>	63	9	50	45	5	32	21.75	9	35	22.5	56.5	50	75
<b>PBIS080</b>	80	12	63	55	6	41	27	11	47	22.5	72	63	95
<b>PBIS100</b>	100	14	71	57	6	41	26.5	11	53	27.5	89	75	115
<b>PBIS125</b>	125	16	90	70	8	45	35	14	70	30	110	90	140
<b>PBIS160</b>	160	18	115	75	9	60	45	18	100	32.5	140	115	180
<b>PBIS200</b>	200	22	135	100	12	70	47.5	18	100	37.5	175	135	220

\* La sigla si riferisce a un solo piedino e non alla coppia

\* The part number is referred to only one element and not to the couple

## CERNIERA INTERMEDIA PER ESTRUSO

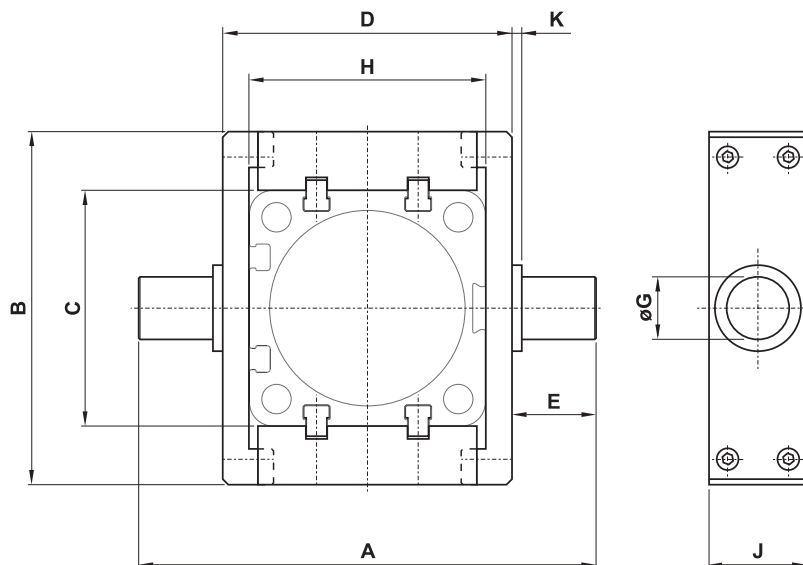

**alesaggi: 32, 40, 50**

bores: 32, 40, 50

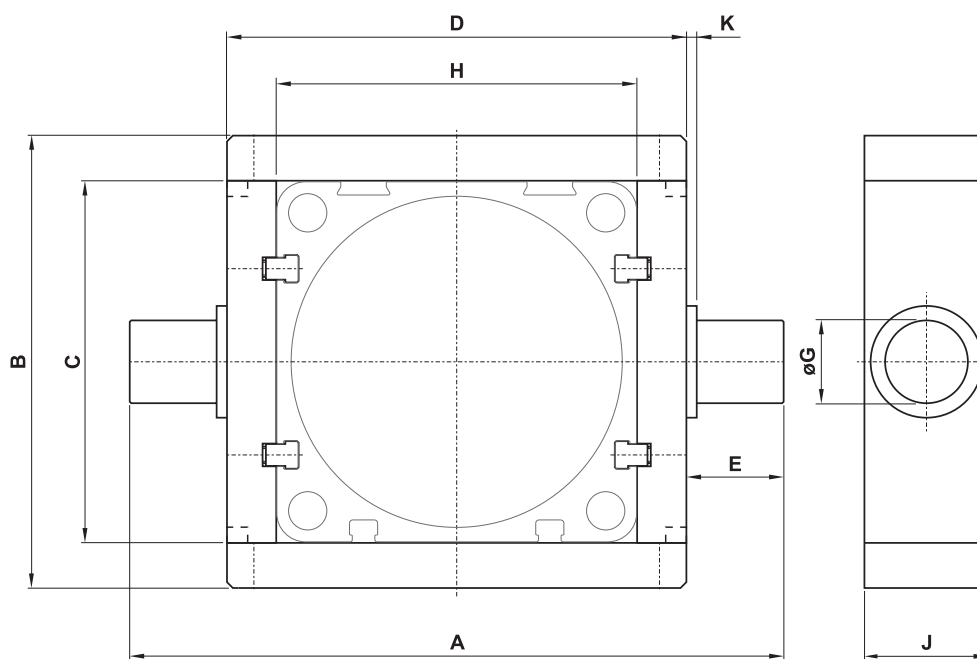

**alesaggi: 63, 80, 100, 125**

bores: 63, 80, 100, 125

sigla part number	per alesaggio for bore	A	B	C	D	E	G	H	J	K
<b>CIN032</b>	32	87	65	44.5	52	17.5	12	45	25	2
<b>CIN040</b>	40	105	74.8	50.5	62	21.5	16	50.8	25	2.5
<b>CIN050</b>	50	117	90.3	60.3	74	21.5	16	60.6	25	2.5
<b>CIN063</b>	63	136	94.5	70.5	91	22.5	20	70	30	2.5
<b>CIN080</b>	80	156	109.3	87.5	111	22.5	20	87	30	2.5
<b>CIN100</b>	100	195	134	106.6	129	33	25	106	40	2.5
<b>CIN125</b>	125	222.7	160	132.6	156.7	33	25	132	40	2.5

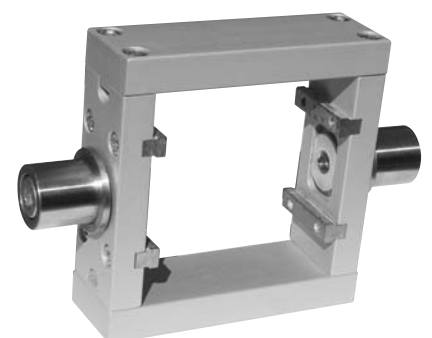

## SNODO PER CERNIERA INTERMEDIA

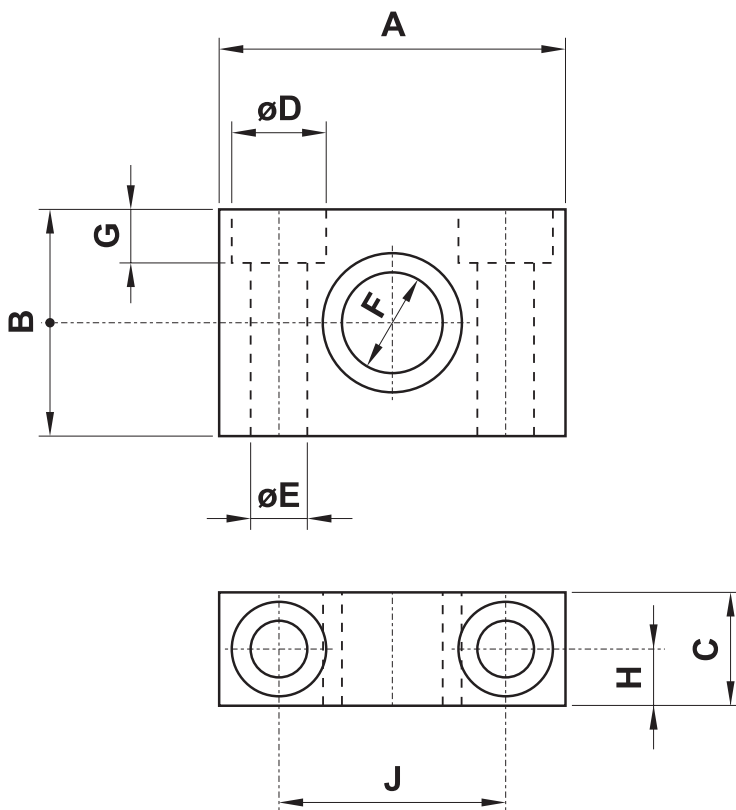

4

sigla* part number*	per alesaggio for bore	A	B	C	D	E	F	G	H	J
<b>SNINT 032 B</b>	32	46	30	15	10.5	6.5	ø12	6.5	7.5	32
<b>SNINT 040-050 B</b>	40-50	55	35	20	14	9	ø16	8	10	36
<b>SNINT 063-080 B</b>	63-80	65	40	20	17	11	ø20	12	10	42
<b>SNINT 100-125 B</b>	100-125	75	50	30	19	14	ø25	10	15	50

\* La sigla si riferisce a una coppia di snodi

\* The part number is referred to a couple of elements

## CERNIERA INTERMEDIA per cilindri da alesaggio 160 e 200 versione a tiranti

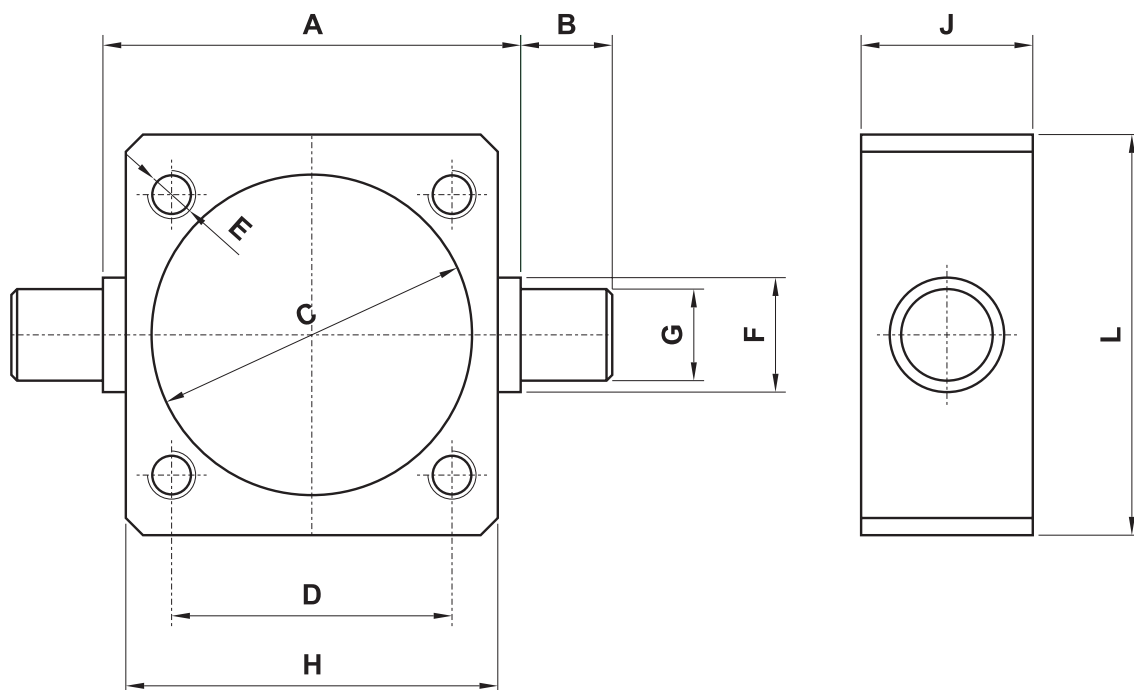

Questa cerniera intermedia può essere montata solo su cilindri a tubo tondo con tiranti. Al momento dell'ordine dei cilindri specificare chiaramente questa caratteristica, fornendo anche precise indicazioni riguardo alla posizione di montaggio della cerniera sul cilindro.

*This fixing element can be mounted only on a cylinder with round barrel and tie-rods. The request for cylinders with tie-rods must be clearly specified on the order. On the order please specify also the position where the fixing element should be mounted on the cylinder.*

sigla part number	per alesaggio for bore	A	B	C	D	E	G	H	J	L
<b>CSIS160TI</b>	160	200	32	∅170	140	M16	∅32	190	40	190
<b>CSIS200TI</b>	200	250	32	∅211	175	M16	∅32	240	40	240

## CONTROCERNIERA ORIZZONTALE A BASE RETTANGOLARE

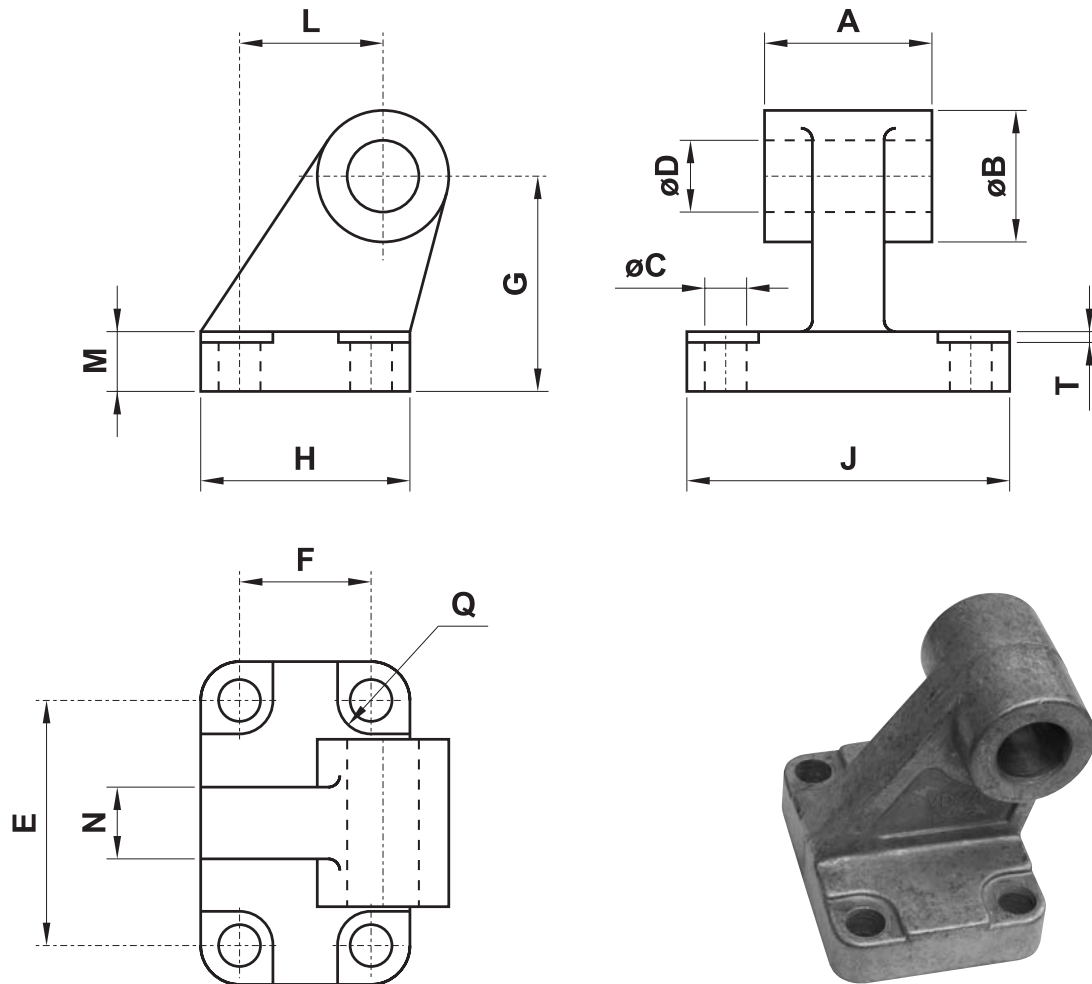

sigla part number	per alesaggio for bore	A	B	C	D	E	F	G	H	J	L	M	N	Q	T
<b>COIS032</b>	32	26	20	6.6	10	38	18	32	31	51	21	8	10	6.6	1.6
<b>COIS040</b>	40	28	22	6.6	12	41	22	36	35	54	24	10	15	6.6	1.6
<b>COIS050</b>	50	32	26	9	12	50	30	45	45	65	33	12	16	9	1.6
<b>COIS063</b>	63	40	30	9	16	52	35	50	50	67	37	14	16	9	1.6
<b>COIS080</b>	80	50	30	11	16	66	40	63	60	86	47	14	20	11	2.5
<b>COIS100</b>	100	60	38	11	20	76	50	71	70	96	55	17	20	11	2.5
<b>COIS125</b>	125	70	45	14	25	94	60	90	90	124	70	20	30	14	3.2
<b>COIS160</b>	160	90	63	14	30	118	88	115	126	156	97	25	36	14	4
<b>COIS200</b>	200	90	63	18	30	122	90	135	130	162	105	30	40	18	4

# fissaggi per cilindri ISO 6431 VDMA

fixing elements for cylinders ISO 6431 VDMA



## CERNIERA MASCHIO SNODO SFERICO

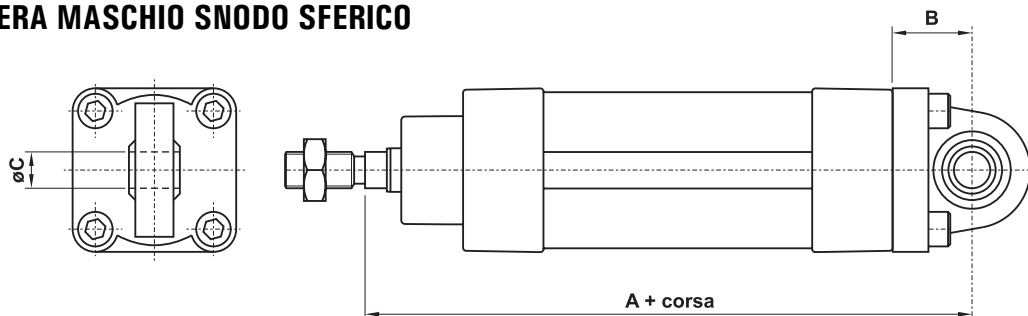

CMSS...

## CERNIERA MASCHIO

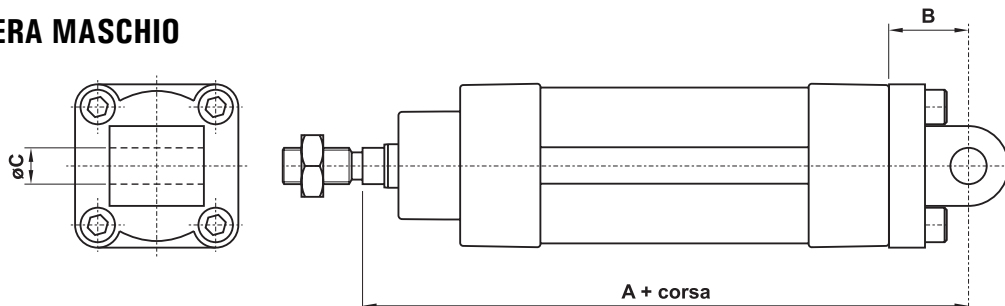

CMIS...

CMKS...

## CERNIERA FEMMINA CON PERNO

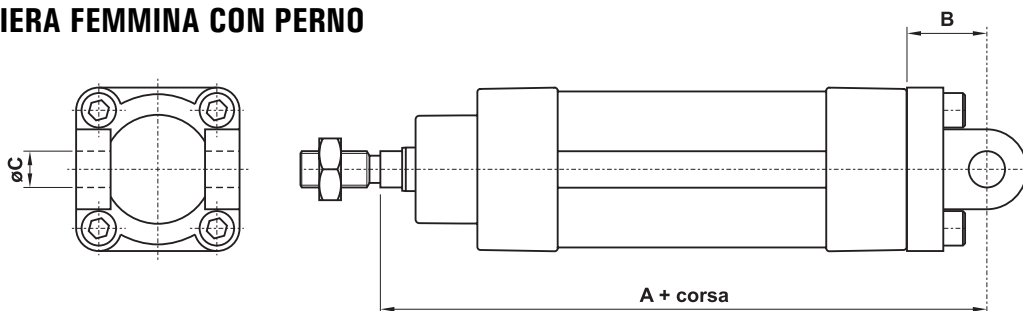

CFIS...

CFKS...

## PIEDINO

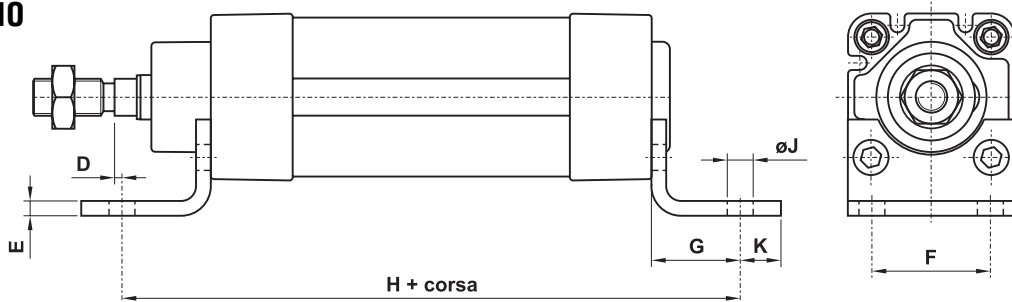

PBIS...

Ø	A	B	C	D	E	F	G	H	J	K
32	142	22	10	2	4	32	24	142	7	11
40	160	25	12	2	4	36	28	161	9	8
50	170	27	12	5	5	45	32	170	9	15
63	190	32	16	5	5	50	32	185	9	13
80	210	36	16	5	6	63	41	210	12	14
100	230	41	20	10	6	75	41	220	14	16
125	275	50	25	20	8	90	45	250	16	25
160	315	55	30	20	9	115	60	300	18	15
200	335	60	30	25	12	135	70	320	22	30



# fissaggi per cilindri ISO 6431 VDMA

fixing elements for cylinders ISO 6431 VDMA



## CERNIERA INTERMEDIA PER ESTRUSO

CIN...  
CSIS...TI

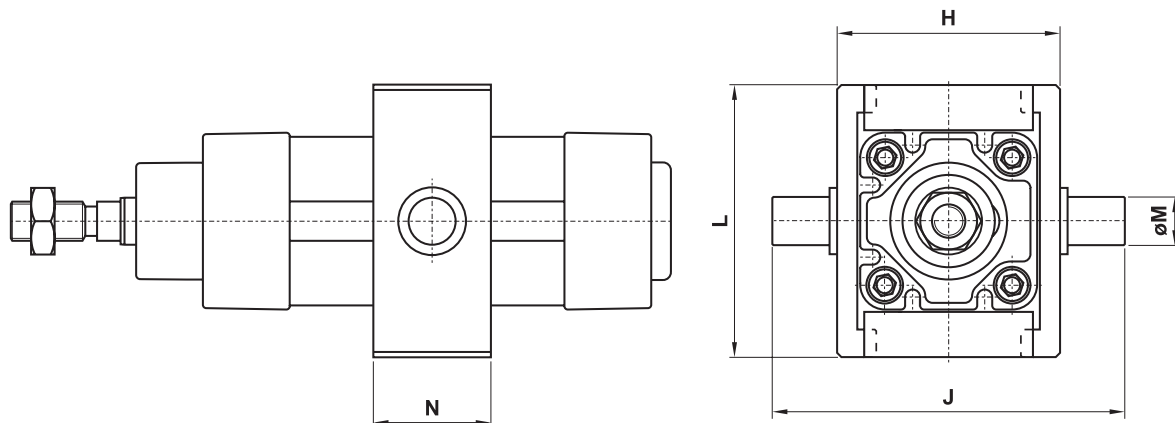

## FLANGIA

FLIS...

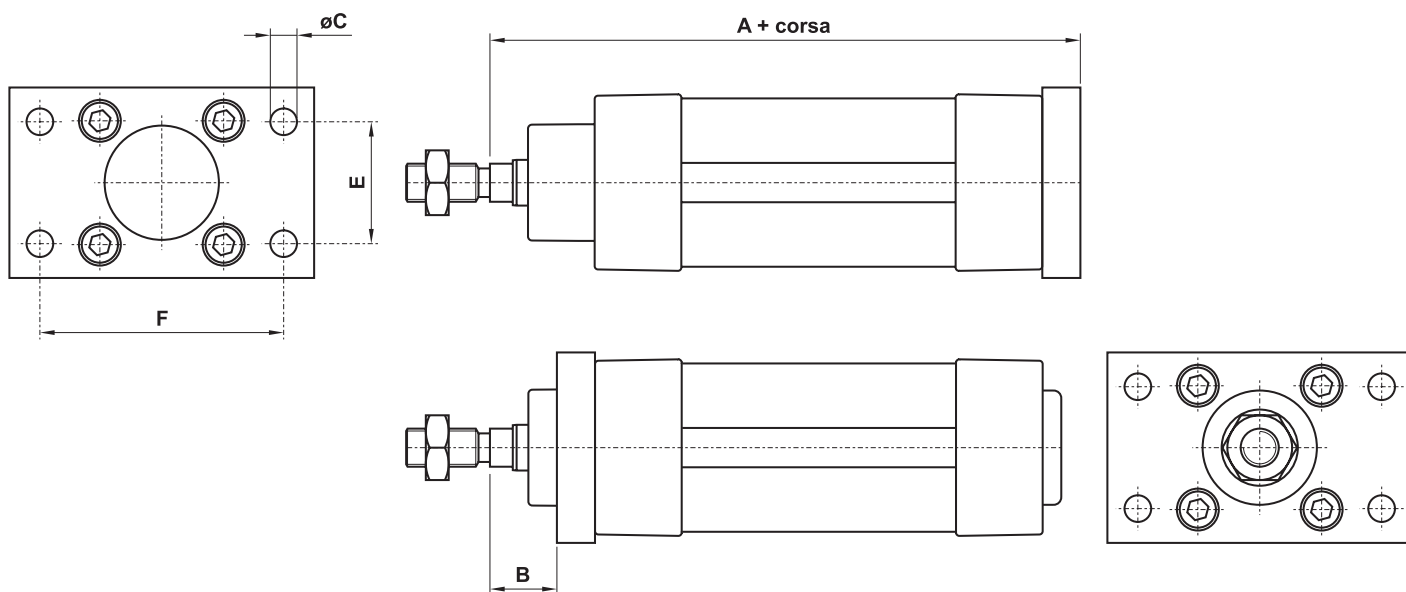

Ø	A	B	C	E	F	H	J	L	M	N
32	130	16	7	32	64	52	87	65	12	25
40	145	20	9	36	72	62	105	74.8	16	25
50	155	25	9	45	90	74	117	90.3	16	25
63	170	25	9	50	100	91	136	94.5	20	30
80	190	30	12	63	126	111	156	109.3	20	30
100	205	35	14	75	150	129	195	134	25	40
125	245	45	16	90	180	156.7	222.7	160	25	40
160	280	60	18	115	230	190	262	200	32	40
200	300	70	22	135	270	240	312	250	32	40

# cilindri ISO 6431 VDMA

*cylinders ISO 6431 VDMA*



- Conformi alla norma ISO 6431 VDMA  
*Compliant to norm ISO 6431 VDMA*
- Grande affidabilità e lunga durata  
*High reliability and long life time*
- Versione magnetica standard  
*Standard magnetic version*
- Esecuzioni e corse speciali a richiesta  
*Special versions and strokes on request*

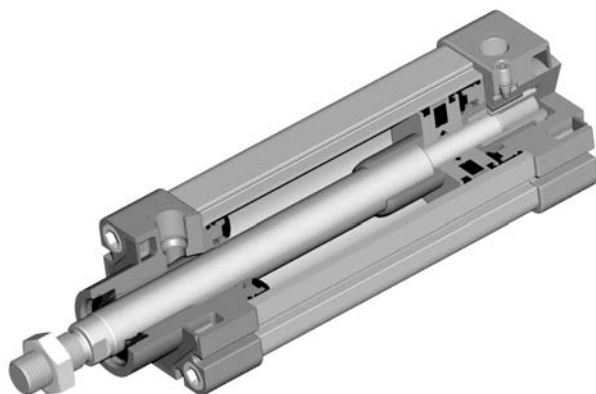

## Materiali

Camicia: alluminio

Stelo: C45 cromato o INOX AISI 304

Testate: alluminio

Pistone: alluminio

Guarnizioni: NBR o VITON

Guarnizione stelo: poliuretano o VITON

Magnete: plastroferrite

## Materials

Barrel: aluminium

Piston-rod: C45 (chromium plated) or stainless steel

End-cups: aluminium

Piston: aluminium

Sealings: NBR or VITON

Piston-rod sealing: polyurethane or VITON

Magnet: magnetic iron compound

Pressione di esercizio <i>Working pressure</i>	max 10 bar max 1 MPa
Temperatura di esercizio <i>Temperature range</i>	NBR: max +60°C VITON: max +110°C
Alesaggi <i>Bores</i>	32; 40; 50; 63; 80; 100; 125; 160; 200 mm
Tipo di costruzione <i>Construction type</i>	ø32 ... 125 : profilo quadro con cava centrale e cave laterali <i>ø32 ... 125 : square aluminium profile</i>
	ø160-200 : tubo tondo con tiranti INOX <i>ø160-200 : round profile with tie-rods in stainless steel</i>
Corse <i>Strokes</i>	25 ... 1000 mm
Ammortizzo pneumatico <i>Pneumatic cushioning</i>	Standard su tutta la gamma <i>Standard on the whole range</i>
Fluido <i>Fluid</i>	Aria filtrata 50µ con o senza lubrificazione <i>50µ filtered, lubricated or non lubricated air</i>



## chiave di codifica

*key to codes*

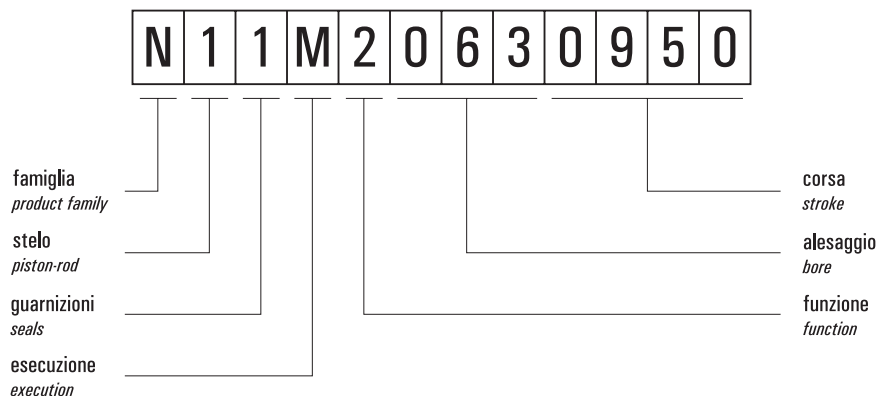

### Famiglia *[product family]*

**N** cilindri ISO 6431  $\varnothing$ 32 ... 200

### Stelo *[piston-rod]*

- 1 C45 cromato *[C45 chromium plated]*
- 2 INOX *[stainless steel]*

### Guarnizioni *[seals]*

- 1 NBR
- 2 tutte le guarnizioni in VITON *[all seals in VITON]*
- 3 guarnizioni dello stelo in VITON *[rod seals in VITON]*

### Esecuzione *[execution]*

- M** magnetico *[magnetic]*
- B** magnetico predisposto per bloccastelo *[magnetic with rod lock adaptor]*

### Funzione *[function]*

- 2** doppio effetto ammortizzato  
*[double acting with pneumatic cushioning]*
- 4** doppio effetto ammortizzato stelo passante  
*[double acting with pneumatic cushioning, with passing-through rod]*

4



## versioni disponibili

available versions

	alesaggio												OPZIONI options									
	corsa	bore	32	40	50	63	80	100	125	160	200											
<b>doppio effetto</b> <i>double acting</i> <b>magnetico</b> <i>magnetic</i> <b>ammortizzato</b> <i>with pneumatic cushioning</i>	25	stroke	X	X	X	X	X	X	X													
	50		X	X	X	X	X	X	X	X	X	X										
	75		X	X	X	X	X	X	X	X												
	80		X	X	X	X	X	X	X	X	X	X										
	100		X	X	X	X	X	X	X	X	X	X	X									
	125		X	X	X	X	X	X	X	X												
	150		X	X	X	X	X	X	X	X	X	X	X									
	160		X	X	X	X	X	X	X	X	X	X	X	X								
	200		X	X	X	X	X	X	X	X	X	X	X	X	X							
	250		X	X	X	X	X	X	X	X	X	X	X	X	X							
	300		X	X	X	X	X	X	X	X	X	X	X	X	X							
	320		X	X	X	X	X	X	X	X	X	X	X	X	X							
	350		X	X	X	X	X	X	X	X	X											
	400		X	X	X	X	X	X	X	X	X	X	X	X	X							
	450		X	X	X	X	X	X	X	X	X											
	500		X	X	X	X	X	X	X	X	X	X	X	X	X							
	550		X	X	X	X	X	X	X	X	X											
	600		X	X	X	X	X	X	X	X	X	X	X	X	X							
	650		X	X	X	X	X	X	X	X	X											
	700		X	X	X	X	X	X	X	X	X	X	X	X	X							
750		X	X	X	X	X	X	X	X	X												
800		X	X	X	X	X	X	X	X	X	X	X	X	X								
850		X	X	X	X	X	X	X	X	X												
900		X	X	X	X	X	X	X	X	X	X	X	X	X								
950		X	X	X	X	X	X	X	X	X												
1000		X	X	X	X	X	X	X	X	X	X	X	X	X								
<b>doppio effetto</b> <i>double acting</i> <b>magnetico</b> <i>magnetic</i> <b>ammortizzato</b> <i>with pneumatic cushioning</i> <b>stelo passante</b> <i>passing-through rod</i>	25	stroke	X	X	X	X	X	X	X	X												
	50		X	X	X	X	X	X	X	X	X	X	X									
	75		X	X	X	X	X	X	X	X												
	80		X	X	X	X	X	X	X	X	X	X	X									
	100		X	X	X	X	X	X	X	X	X	X	X	X								
	125		X	X	X	X	X	X	X	X												
	150		X	X	X	X	X	X	X	X	X	X	X	X								
	160		X	X	X	X	X	X	X	X	X	X	X	X	X							
	200		X	X	X	X	X	X	X	X	X	X	X	X	X							
	250		X	X	X	X	X	X	X	X	X	X	X	X	X							
	300		X	X	X	X	X	X	X	X	X	X	X	X	X							
	320		X	X	X	X	X	X	X	X	X	X	X	X	X							
	350		X	X	X	X	X	X	X	X	X											
	400		X	X	X	X	X	X	X	X	X	X	X	X	X							
	450		X	X	X	X	X	X	X	X	X											
	500		X	X	X	X	X	X	X	X	X	X	X	X	X							
	550		X	X	X	X	X	X	X	X	X											
	600		X	X	X	X	X	X	X	X	X	X	X	X	X							
	650		X	X	X	X	X	X	X	X	X											
	700		X	X	X	X	X	X	X	X	X	X	X	X	X							
750		X	X	X	X	X	X	X	X	X												
800		X	X	X	X	X	X	X	X	X	X	X	X	X								
850		X	X	X	X	X	X	X	X	X												
900		X	X	X	X	X	X	X	X	X	X	X	X	X								
950		X	X	X	X	X	X	X	X	X												
1000		X	X	X	X	X	X	X	X	X	X	X	X	X								

# cilindri ISO 6431 VDMA

*cylinders ISO 6431 VDMA*



disegno valido dall'alesaggio 32 all'alesaggio 125  
*the drawing is valid from bore 32 to bore 125*

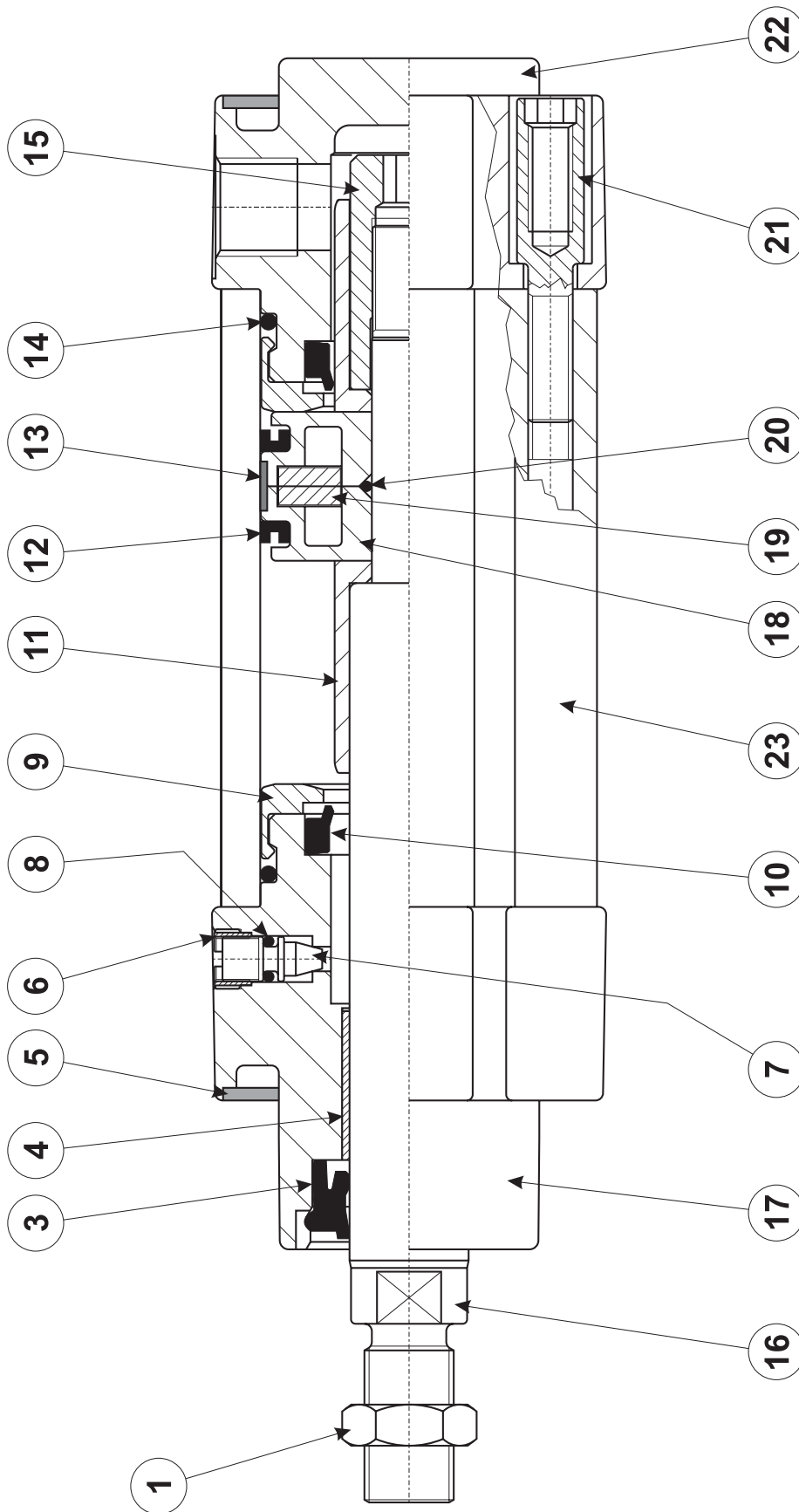

- 1. Dado esagonale per stelo
- 3. Guarnizione stelo: POLIURETANO o VITON
- 4. Boccola guida: materiale autolubrificante
- 5. Piastrina di protezione: MOPLEN
- 6. Ghiera per vite ammortizzo: ottone nichelato
- 7. Vite ammortizzo: ottone nichelato
- 8. Guarnizione O-Ring per vite ammortizzo: NBR o VITON
- 9. Paracolpi: HYTREL
- 10. Guarnizione ammortizzo: NBR o VITON
- 11. Ogvia: alluminio
- 12. Guarnizione a labbro per pistone: NBR o VITON
- 13. Anello guida per pistone: bronzo PTFE
- 14. O-Ring per tenuta testate: NBR o VITON
- 15. Bussola per bloccaggio stelo: materiale UNI 5105 35S Mn Pb 10, zincato
- 16. Stelo: acciaio C45 cromato o INOX AISI 304
- 17. Testata anteriore: lega alluminio da pressofusione
- 18. Pistone: alluminio
- 19. Magnete: plastoferrite
- 20. O-Ring per tenuta pistone: NBR o VITON
- 21. Vite per assemblaggio testate: autofilettante fino all'alesaggio 63, poi normale a maschiare
- 22. Testata posteriore: lega alluminio da pressofusione
- 23. Camicia: alluminio profilato, calibrato e anodizzato

# cilindri ISO 6431 VDMA

*cylinders ISO 6431 VDMA*



disegno valido per l'alesaggio 160 e 200  
the drawing is valid for bore 160 and 200

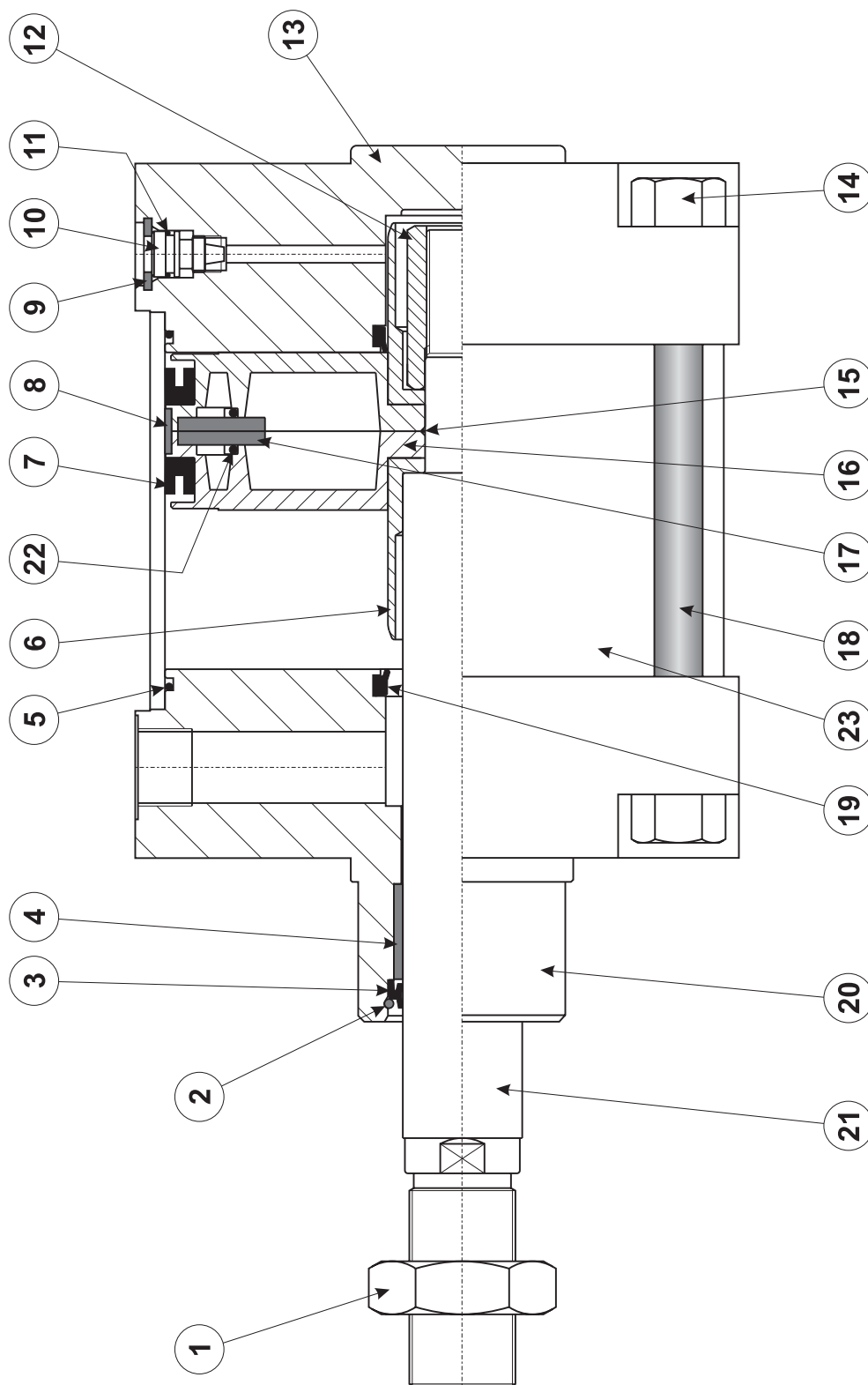

- 1. Dado esagonale per stelo
- 2. Anello INOX per fissaggio guarnizione
- 3. Guarnizione stelo: NBR o VITON
- 4. Boccola guida: bronzo sinterizzato
- 5. O-Ring per tenuta testate: NBR o VITON
- 6. Ogiva: alluminio
- 7. Guarnizione a labbro per pistone: NBR o VITON
- 8. Anello guida per pistone
- 9. Anello per sicurezza ammortizzo
- 10. Vite ammortizzo: ottone OT 58
- 11. Guarnizione O-Ring per vite ammortizzo: NBR o VITON

- 12. Bussola per bloccaggio stelo
- 13. Testata posteriore: lega alluminio da fusione in conchiglia
- 14. Vite per assemblaggio testate
- 15. O-Ring per tenuta pistone: NBR o VITON
- 16. Pistone: alluminio
- 17. Magnete: plastroferrite
- 18. Tirante: INOX
- 19. Guarnizione ammortizzo: NBR o VITON
- 20. Testata anteriore: lega alluminio da fusione in conchiglia
- 21. Stelo: acciaio C45 cromato o INOX AISI 304
- 22. Guarnizione O-Ring per tenuta pistone: NBR o VITON
- 23. Camicia: alluminio, tubo tondo

# cilindri ISO 6431 VDMA

*cylinders ISO 6431 VDMA*

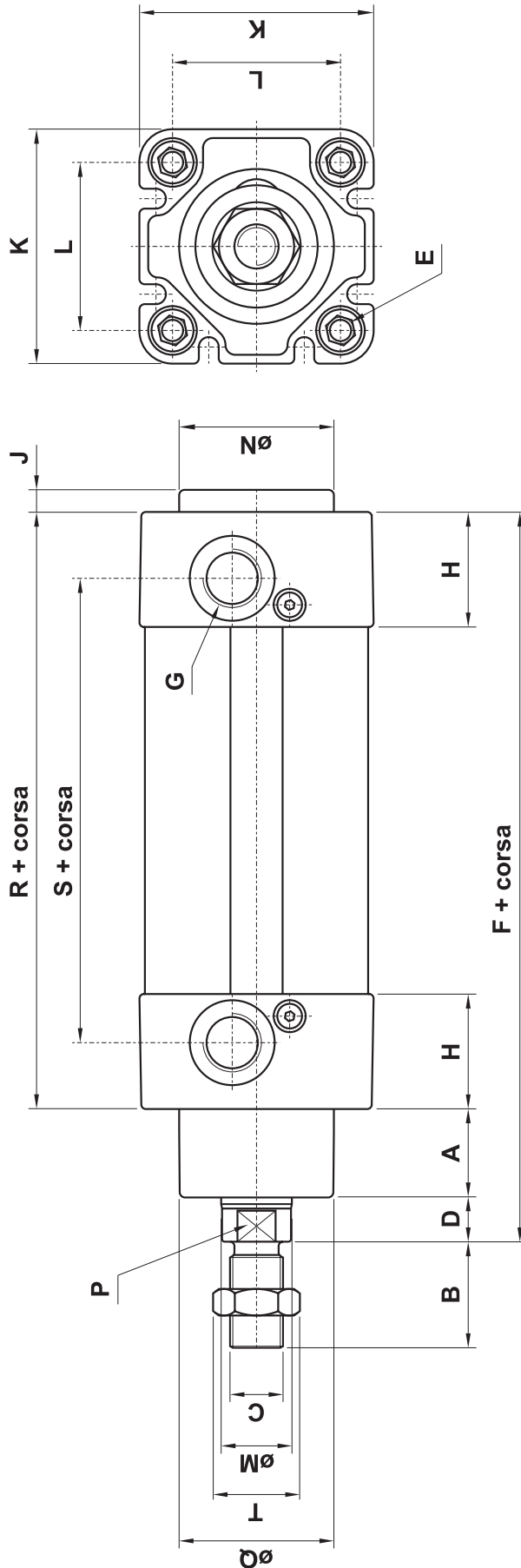

$\varnothing$	A	B	C	D	E	F	G	H	J	K	L	M	N	P	Q	R	S	T
32	16	22	M10x1.25	10	M6	120	G1/8"	25.5	5	47	32.5	12	30	CH 10	30	94	63.6	CH 17
40	20	24	M12x1.25	10	M6	135	G1/4"	28	5	53	38	16	35	CH 13	35	105	76	CH 19
50	25	32	M16x1.5	12	M8	143	G1/4"	30	5	64	46.5	20	40	CH 17	40	106	69.4	CH 24
63	25	32	M16x1.5	12	M8	158	G3/8"	31	5	74	56.5	20	45	CH 17	45	121	85.2	CH 24
80	32.5	40	M20x1.5	13.5	M10	174	G3/8"	34	5	94	72	25	45	CH 22	45	128	90	CH 30
100	35	40	M20x1.5	16	M10	189	G1/2"	35	5	112	89	25	55	CH 22	55	138	104	CH 30
125	40	54	M27x2	25	M12	225	G1/2"	41	5	136	110	32	60	CH 27	60	160	112	CH 41

4

# cilindri ISO 6431 VDMA

*cylinders ISO 6431 VDMA*

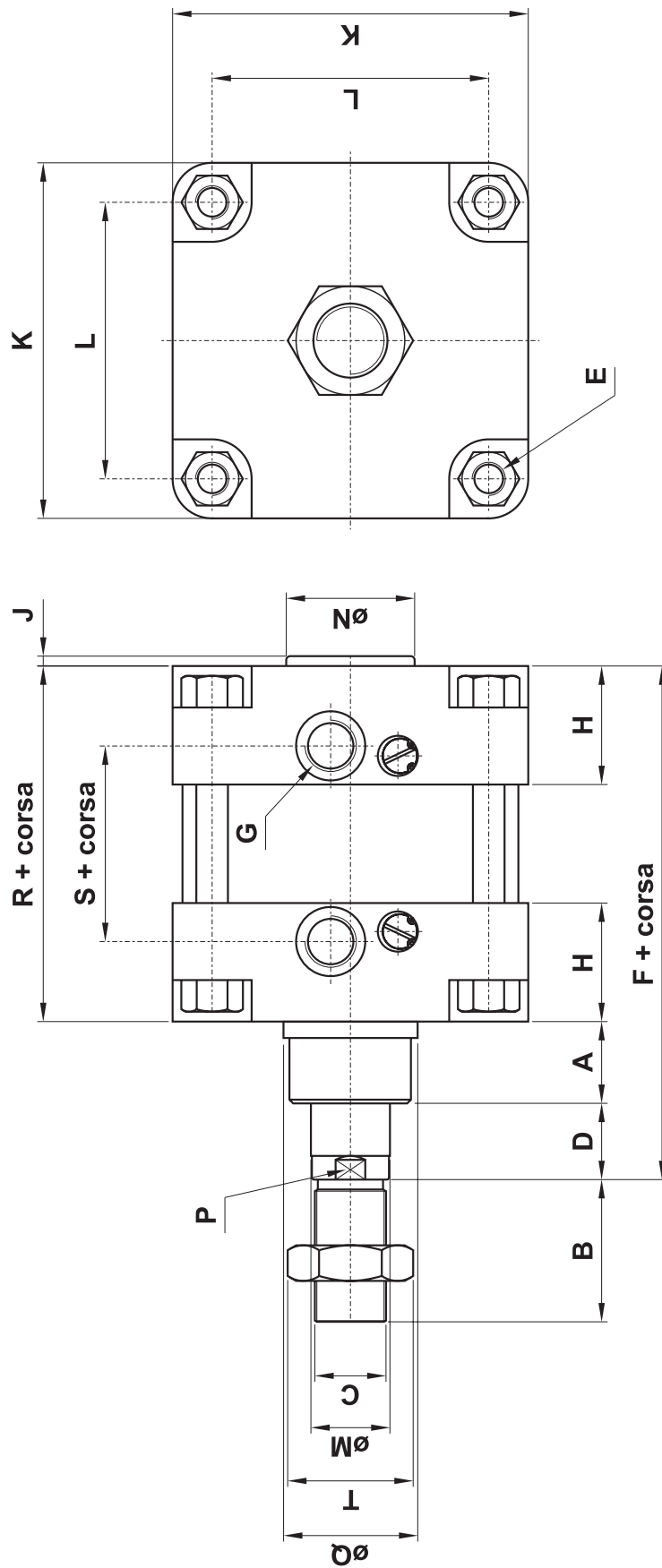

$\varnothing$	A	B	C	D	E	F	G	H	J	K	L	M	N	P	Q	R	S	T
160	50	72	M36x2	30	M16	260	63/4"	50	6	180	140	40	65	CH 36	65	180	120	CH 55
200	55	72	M36x2	40	M16	275	63/4"	50	6	220	175	40	75	CH 36	75	180	120	CH 55



# cilindri ISO 6431 VDMA

cylinders ISO 6431 VDMA



## VERSIONE STELO PASSANTE

Version with passing-through rod

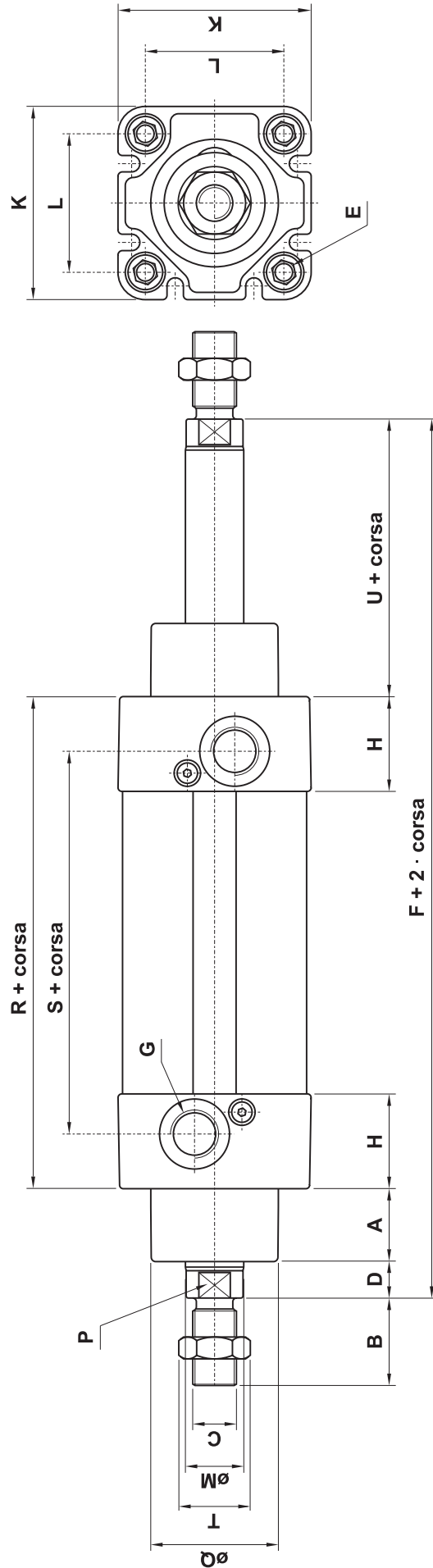

Ø	A	B	C	D	E	F	G	H	K	L	M	P	Q	R	S	T	U
32	16	22	M10x1.25	10	M6	146	G1/8"	25.5	47	32.5	12	CH 10	30	94	63.6	CH 17	26
40	20	24	M12x1.25	10	M6	165	G1/4"	28	53	38	16	CH 13	35	105	75	CH 19	30
50	25	32	M16x1.5	12	M8	180	G1/4"	30	64	46.5	20	CH 17	40	106	69.4	CH 24	37
63	25	32	M16x1.5	12	M8	195	G3/8"	31	74	56.5	20	CH 17	45	121	85.2	CH 24	37
80	32.5	40	M20x1.5	13.5	M10	220	G3/8"	34	94	72	25	CH 22	45	128	90	CH 30	46
100	35	40	M20x1.5	16	M10	240	G1/2"	35	112	89	25	CH 22	55	138	104	CH 30	51
125	40	54	M27x2	25	M12	290	G1/2"	41	136	110	32	CH 27	60	160	112	CH 41	65

# cilindri ISO 6431 VDMA

*cylinders ISO 6431 VDMA*



## VERSIONE STELO PASSANTE

*Version with passing-through rod*

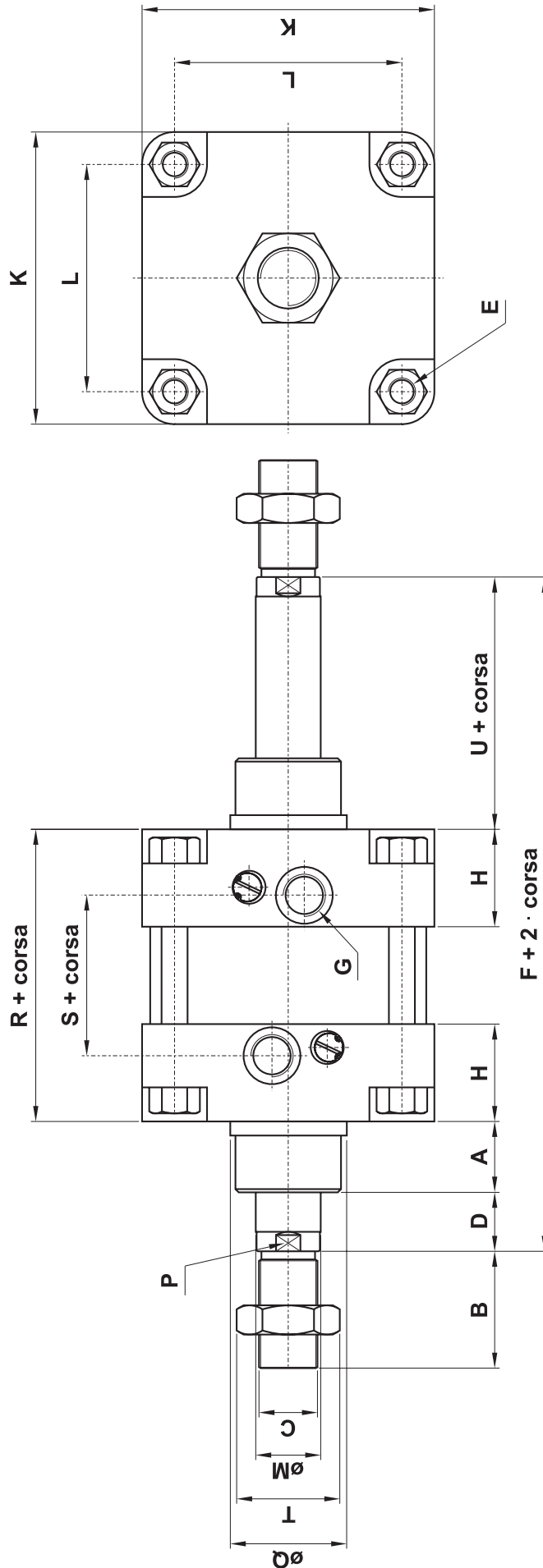

Ø	A	B	C	D	E	F	G	H	K	L	M	P	Q	R	S	T	U
160	50	72	M36x2	30	M16	340	G3/4"	50	180	140	40	CH 36	65	180	120	CH 55	80
200	55	72	M36x2	40	M16	370	G3/4"	50	220	175	40	CH 36	75	180	120	CH 55	95

## kit guarnizioni di ricambio

seals kit

## MAGNETICO, guarnizioni standard

normale			stelo passante <i>[passing-through rod]</i>		
per alesaggio <i>for bore</i>	sigla <i>part number</i>	codice <i>code</i>	per alesaggio <i>for bore</i>	sigla <i>part number</i>	codice <i>code</i>
32	<b>SGM032</b>	21.100.2	32	<b>SGM032P</b>	21.110.2
40	<b>SGM040</b>	21.101.2	40	<b>SGM040P</b>	21.111.2
50	<b>SGM050</b>	21.102.2	50	<b>SGM050P</b>	21.112.2
63	<b>SGM063</b>	21.103.2	63	<b>SGM063P</b>	21.113.2
80	<b>SGM080</b>	21.104.2	80	<b>SGM080P</b>	21.114.2
100	<b>SGM100</b>	21.105.2	100	<b>SGM100P</b>	21.115.2
125	<b>SGM125</b>	21.106.2	125	<b>SGM125P</b>	21.116.2
160	<b>SGM160</b>	21.107.2	160	<b>SGM160P</b>	21.117.2
200	<b>SGM200</b>	21.108.2	200	<b>SGM200P</b>	21.118.2

## MAGNETICO, guarnizioni VITON

normale			stelo passante <i>[passing-through rod]</i>		
per alesaggio <i>for bore</i>	sigla <i>part number</i>	codice <i>code</i>	per alesaggio <i>for bore</i>	sigla <i>part number</i>	codice <i>code</i>
32	<b>SGM032V</b>	21.120.2	32	<b>SGM032PV</b>	21.130.2
40	<b>SGM040V</b>	21.121.2	40	<b>SGM040PV</b>	21.131.2
50	<b>SGM050V</b>	21.122.2	50	<b>SGM050PV</b>	21.132.2
63	<b>SGM063V</b>	21.123.2	63	<b>SGM063PV</b>	21.133.2
80	<b>SGM080V</b>	21.124.2	80	<b>SGM080PV</b>	21.134.2
100	<b>SGM100V</b>	21.125.2	100	<b>SGM100PV</b>	21.135.2
125	<b>SGM125V</b>	21.126.2	125	<b>SGM125PV</b>	21.136.2
160	<b>SGM160V</b>	21.127.2	160	<b>SGM160PV</b>	21.137.2
200	<b>SGM200V</b>	21.128.2	200	<b>SGM200PV</b>	21.138.2

## kit cilindro

*cylinder kit*

### Il kit comprende:

- testate premontate con boccola, paracolpi e ammortizzo
- pistone con magnete, guarnizioni e anello di guida
- ogive
- viti
- piastrine di protezione
- tutte le guarnizioni necessarie

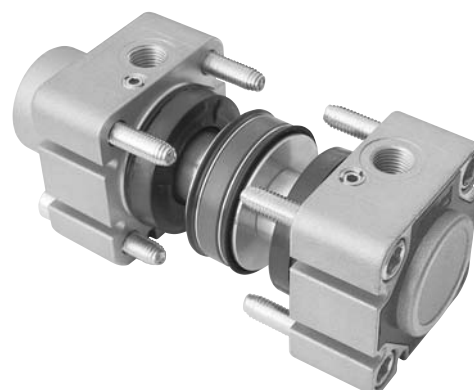

### MAGNETICO, guarnizioni standard

normale			stelo passante <i>[passing-through rod]</i>		
per alesaggio <i>for bore</i>	sigla <i>part number</i>	codice <i>code</i>	per alesaggio <i>for bore</i>	sigla <i>part number</i>	codice <i>code</i>
32	<b>KSM032</b>	21.001.3	32	<b>KSM032P</b>	21.011.3
40	<b>KSM040</b>	21.002.3	40	<b>KSM040P</b>	21.012.3
50	<b>KSM050</b>	21.003.3	50	<b>KSM050P</b>	21.013.3
63	<b>KSM063</b>	21.004.3	63	<b>KSM063P</b>	21.014.3
80	<b>KSM080</b>	21.005.3	80	<b>KSM080P</b>	21.015.3
100	<b>KSM100</b>	21.006.3	100	<b>KSM100P</b>	21.016.3
125	<b>KSM125</b>	21.007.3	125	<b>KSM125P</b>	21.017.3
160	<b>KSM160</b>	21.008.3	160	<b>KSM160P</b>	21.018.3
200	<b>KSM200</b>	21.009.3	200	<b>KSM200P</b>	21.019.3

### MAGNETICO, guarnizioni VITON

normale			stelo passante <i>[passing-through rod]</i>		
per alesaggio <i>for bore</i>	sigla <i>part number</i>	codice <i>code</i>	per alesaggio <i>for bore</i>	sigla <i>part number</i>	codice <i>code</i>
32	<b>KSM032V</b>	21.021.3	32	<b>KSM032PV</b>	21.031.3
40	<b>KSM040V</b>	21.022.3	40	<b>KSM040PV</b>	21.032.3
50	<b>KSM050V</b>	21.023.3	50	<b>KSM050PV</b>	21.033.3
63	<b>KSM063V</b>	21.024.3	63	<b>KSM063PV</b>	21.034.3
80	<b>KSM080V</b>	21.025.3	80	<b>KSM080PV</b>	21.035.3
100	<b>KSM100V</b>	21.026.3	100	<b>KSM100PV</b>	21.036.3
125	<b>KSM125V</b>	21.027.3	125	<b>KSM125PV</b>	21.037.3
160	<b>KSM160V</b>	21.028.3	160	<b>KSM160PV</b>	21.038.3
200	<b>KSM200V</b>	21.029.3	200	<b>KSM200PV</b>	21.039.3

Maggiori informazioni sono disponibili all'indirizzo internet <http://www.azpneumatica.com/azweb/ita/kitcil.htm>

More information is available at the internet address <http://www.azpneumatica.com/azweb/ita/kitcil.htm>

## istruzioni per il montaggio dei kit cilindro

*instructions to assemble cylinder kit*

### ISTRUZIONI PER L'USO DEI KIT MONTAGGIO CILINDRI ISO 6431

I componenti contenuti nei kit AZ Pneumatica per il montaggio dei cilindri pneumatici ISO 6431 sono costruiti con materiali di prima qualità. Le testate pressofuse e tutti i componenti interni sono lavorati con torni e centri di lavoro a controllo numerico, assicurando così qualità costante e preciso rispetto delle tolleranze dimensionali. Le caratteristiche costruttive e progettuali del cilindro offrono alte prestazioni anche nelle condizioni di lavoro più difficili.

Per far sì che dette qualità divengano effettive, è necessario che il montaggio sia eseguito esattamente secondo le istruzioni qui sotto riportate. È necessario altresì rispettare tutte le norme di sicurezza durante il montaggio e il collaudo del cilindro.

### 1. OPERAZIONI PRELIMINARI

Prima del montaggio soffiare con aria compressa e pulire accuratamente, senza danneggiare le superfici di tenuta, tutti i componenti e l'interno della camicia precedentemente tagliata alla lunghezza desiderata. Il cilindro deve essere montato in un ambiente di lavoro pulito e privo di polvere.

### 2. MONTAGGIO DEL PISTONE SULLO STELO

Sullo stelo infilare, in ordine, facendo riferimento alla figura 1, i seguenti componenti: ogiva, semipistone, guarnizione O-Ring, magneti (i quali devono attrarsi), semipistone, ogiva.

Prima di avvitare il dado di serraggio mettere sul filetto dello stelo una-due gocce di frenafili (Loctite 242 o simile). Avvitare il dado sullo stelo rispettando il momento di serraggio indicato nella seguente tabella:

alesaggio <i>bore</i>	momento di serraggio <i>torque</i>
32	10 Nm
40	20 Nm
50	30 Nm
63	45 Nm
80	60 Nm
100	60 Nm
125	70 Nm

### 3. INSERIMENTO DEL BLOCCO STELO-PISTONE NELLA CAMICIA

Con un grasso adatto (da ordinarsi eventualmente alla AZ Pneumatica) lubrificare leggermente l'interno della camicia, le guarnizioni del pistone e le guarnizioni delle testate.

Posizionare attorno al pistone l'anello guida in teflon-rame (vedi figura 2), lubrificato con grasso, e infilare nella camicia (vedi figura 3) il blocco stelo-pistone precedentemente assemblato, facendo attenzione a non danneggiare le guarnizioni del pistone. Per facilitare questa operazione è possibile ordinare un apposito adattatore alla AZ Pneumatica.

figura 1



figura 2



figura 3

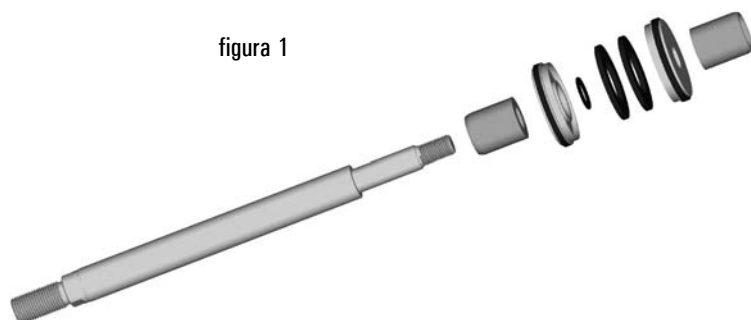

## 4. MONTAGGIO DELLE TESTATE

Infilare la testata anteriore e posteriore nel tubo, facendo attenzione a non danneggiare le guarnizioni O-Ring.

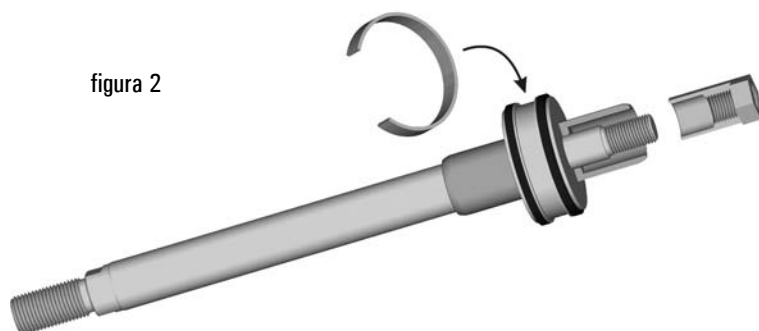
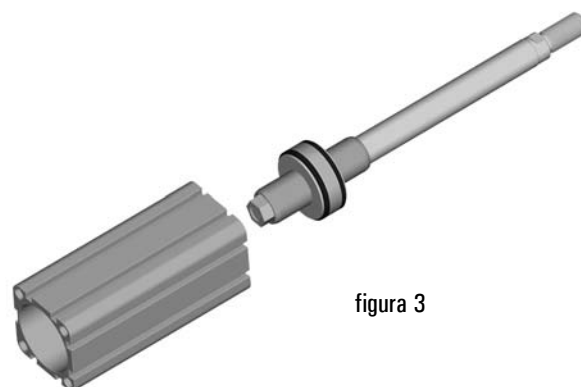
Le viti di serraggio delle testate sono autofilettanti fino al filetto M8 (cioè al cilindro alesaggio 63). Per le viti di diametro superiore è consigliabile filettare la camicia, anche se è possibile, seppure con fatica, utilizzarle come se fossero autofilettanti. In ogni caso è necessario, prima di procedere ad avvitare le viti, lubrificare il filetto con qualche goccia di olio idraulico. Avvitare manualmente o con un utensile pneumatico quasi fino alla fine. Per stringere definitivamente le viti occorre utilizzare una chiave dinamometrica o un utensile pneumatico con indicazione del momento di serraggio. Agire in modo progressivo fino a raggiungere il momento indicato nella tabella seguente:

### MOMENTO DI SERRAGGIO PER LE VITI DI MONTAGGIO TESTATE

alesaggio <i>bore</i>	momento di serraggio <i>torque</i>
32	10 Nm
40	10 Nm
50	22 Nm
63	22 Nm
80	40 Nm
100	40 Nm
125	50 Nm



figura 4

Avvitare il dado sulla parte anteriore dello stelo, e con ciò il cilindro è montato.

## 5. COLLAUDO

Collegare il cilindro a una valvola 5 vie e azionarlo alcune volte per verificarne preliminarmente il corretto funzionamento.

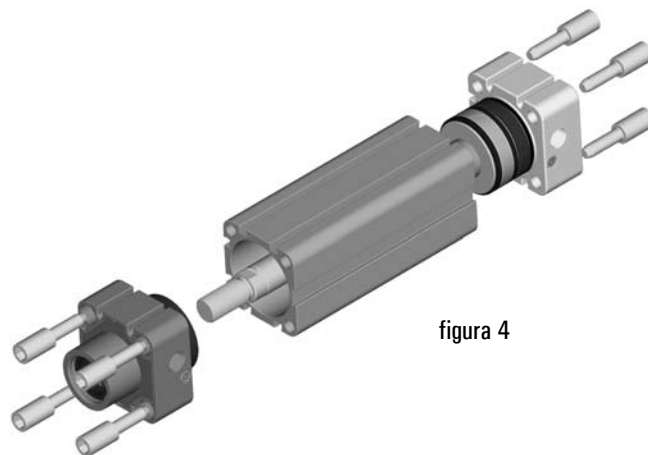
Effettuare poi le operazioni qui di seguito descritte alla pressione di 2 bar e alla pressione di 7 bar (o più).

- verificare la perfetta tenuta della testata anteriore e della sede della vite di ammortizzo;
- verificare la perfetta tenuta della testata posteriore e della sede della vite di ammortizzo;
- verificare la perfetta tenuta della guarnizione raschiastelo;
- verificare la perfetta tenuta del pistone tra le due camere.

Per ovvi motivi, le suddette operazioni vanno eseguite con alimentazione d'aria inserita.

Una volta verificata la perfetta tenuta del cilindro in ogni sua parte, regolare gli ammortizzi secondo necessità e inserire, eventualmente, i tappi nelle bocche di alimentazione. Il cilindro è con ciò pronto per essere utilizzato.

Nel caso di dubbi si prega contattare la AZ Pneumatica.

# barre per camicia cilindri ISO 6431 VDMA

barrel for cylinders ISO 6431 VDMA



	codice di ordinazione <i>order code</i>	dimensioni - <i>dimensions</i> [mm]					peso <i>weight</i> [kg/m]
		A	B	C	D	E	
	<b>000.510.7</b>	ø32 H11	32.5	44.5	17	-	2.198
	<b>000.511.7</b>	ø40 H11	38	50.5	23	-	2.506
	<b>000.512.7</b>	ø50 H11	46.5	60.3	26	-	3.394
	<b>000.513.7</b>	ø63 H11	56.5	70	37	35	3.452
	<b>000.514.7</b>	ø80 H11	72	87	45	45	5.214
	<b>000.515.7</b>	ø100 H12	89	106	50	46	5.619
	<b>000.516.7</b>	ø125 H12	110	132	56	50	7.788

composizione chimica <i>chemical composition</i>	Cu	Fe	Mn	Mg	Si	Zn	Cr	Ti	Al resto
	≤ 0.10	≤ 0.35	≤ 0.10	0.45÷0.90	0.20÷0.60	≤ 0.10	≤ 0.10	≤ 0.10	

## Fori di fissaggio

dal ø32 al ø63 : predisposti per la filettatura metrica mediante rullatura o per l'impiego di viti autofilettanti

dal ø80 al ø125 : predisposti per la filettatura metrica mediante rullatura

## Fixing holes

from ø32 to ø63 : prepared for metric thread through rolling or self-tapping screws

from ø80 to ø125 : prepared for metric thread through rolling

## CERNIERA MASCHIO SNODO SFERICO

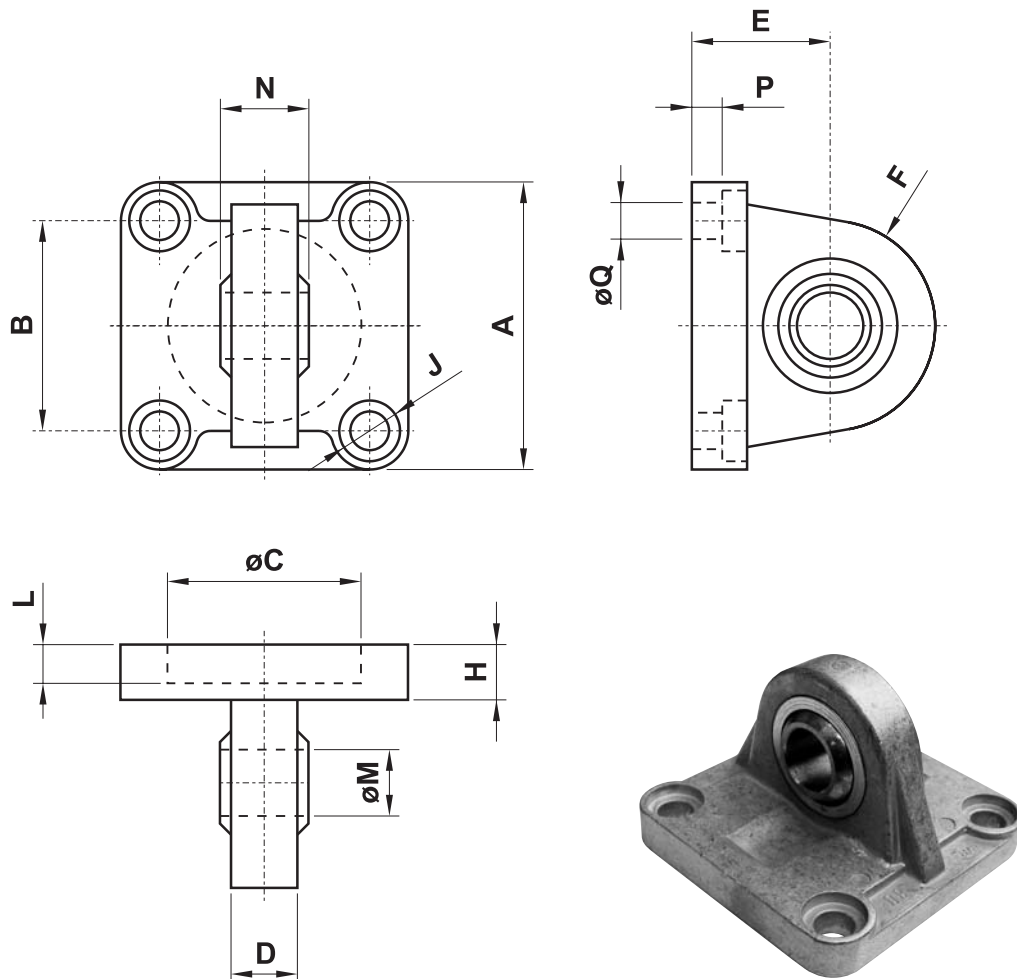

sigla part number	per alesaggio for bore	A	B	C	D	E	F	H	J	L	M	N	P	Q
CMSS032	32	45	32.5	30	10.5	22	16	9	Ø11	5	10	14	5.5	6.6
CMSS040	40	52	38	35	12	25	19	9	Ø11	5	12	16	5.5	6.6
CMSS050	50	65	46.5	40	15	27	21	11	Ø15	5	16	21	6.5	9
CMSS063	63	75	56.5	45	15	32	24	11	Ø15	5	16	21	6.5	9
CMSS080	80	95	72	45	18	36	28.5	14	Ø18	5	20	25	10	11
CMSS100	100	115	89	55	18	41	30	14	Ø18	5	20	25	10	11
CMSS125	125	140	110	60	25	50	40	20	Ø20	7	30	37	10	13.5
CMSS160	160	180	140	65	28	55	45	20	Ø26	7	35	43	10	18
CMSS200	200	220	175	75	28	60	48	25	Ø26	7	35	43	11	18



## CERNIERA MASCHIO

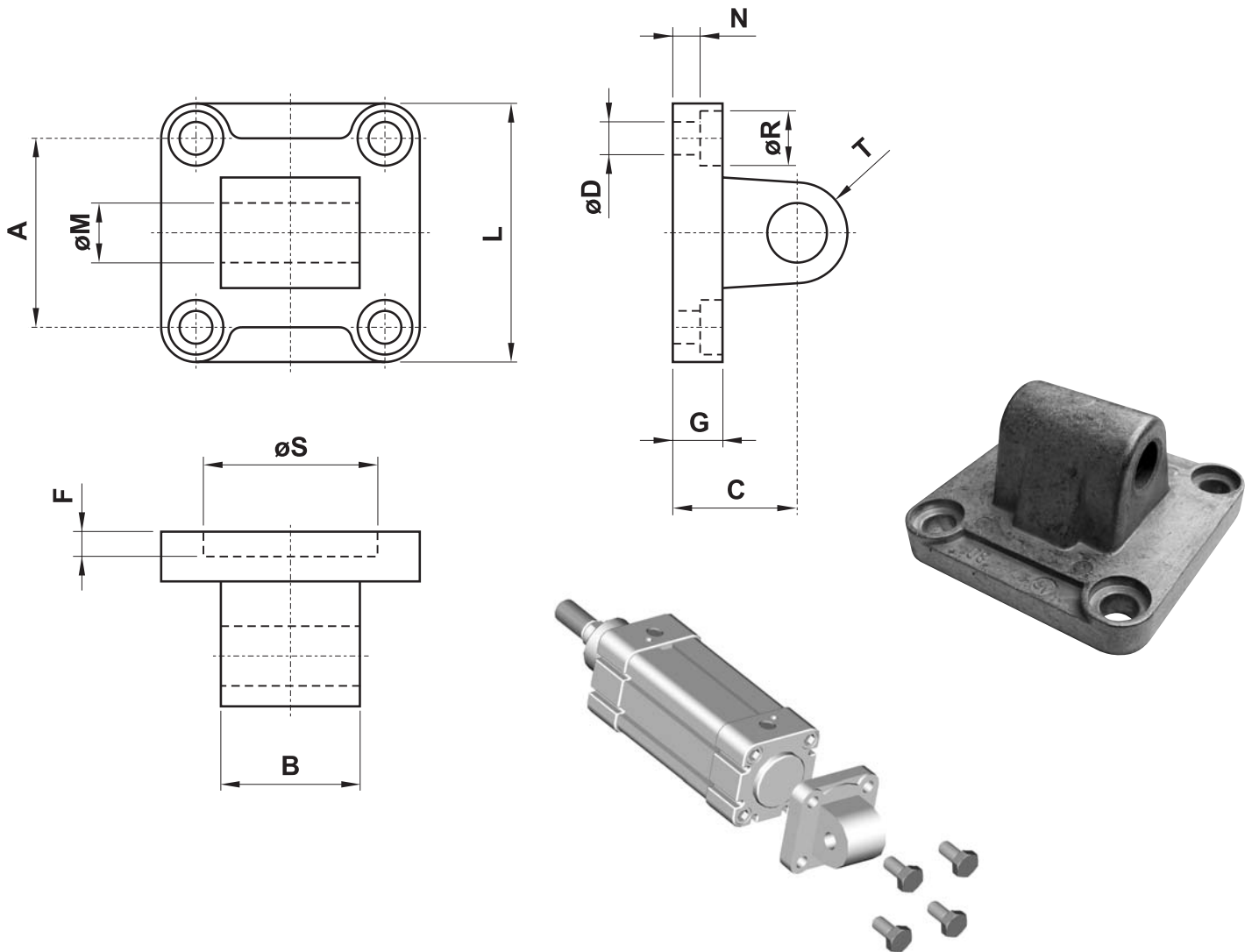

sigla part number	sigla part number	per alesaggio for bore	A	B	C	D	F	G	L	M	N	R	S	T
standard	con boccola di bronzo													
<b>CMIS032</b>	<b>CMKS032</b>	32	32.5	26	22	6.6	5	9	45	10	5.5	11	30	10
<b>CMIS040</b>	<b>CMKS040</b>	40	38	28	25	6.6	5	9	52	12	5.5	11	35	12
<b>CMIS050</b>	<b>CMKS050</b>	50	46.5	32	27	9	5	11	65	12	6.5	15	40	12
<b>CMIS063</b>	<b>CMKS063</b>	63	56.5	40	32	9	5	11	75	16	6.5	15	45	16
<b>CMIS080</b>	<b>CMKS080</b>	80	72	50	36	11	5	14	95	16	10	18	45	16
<b>CMIS100</b>	<b>CMKS100</b>	100	89	60	41	11	5	14	115	20	10	18	55	20
<b>CMIS125</b>	<b>CMKS125</b>	125	110	70	50	14	7	20	140	25	10	20	60	25
<b>CMIS160</b>	<b>CMKS160</b>	160	140	90	55	18	7	20	180	30	10	26	65	25
<b>CMIS200</b>	<b>CMKS200</b>	200	175	90	60	18	7	25	220	30	11	26	75	25



## CERNIERA FEMMINA CON PERNO

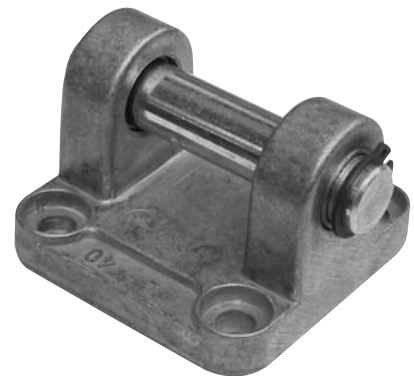
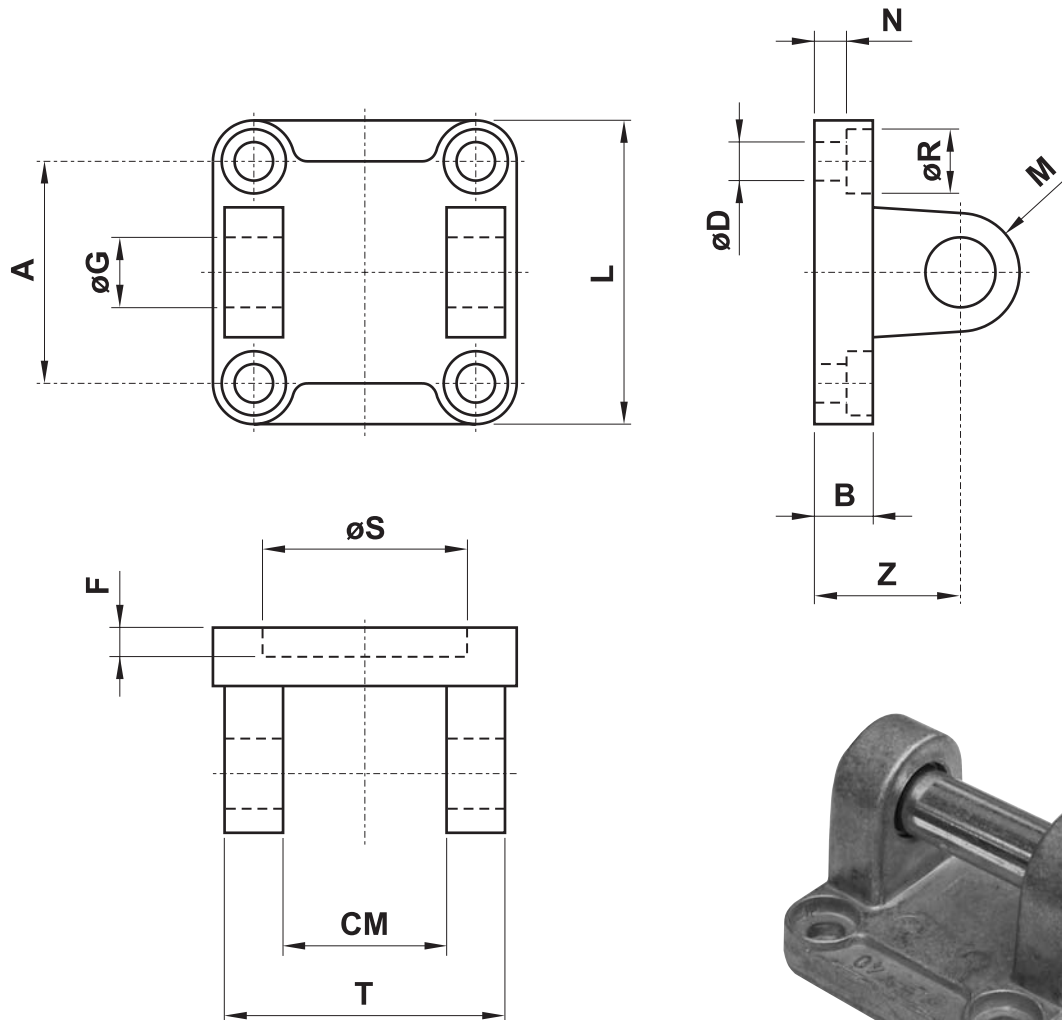

sigla part number	sigla part number	per alesaggio for bore	A	B	CM	D	F	G	L	M	N	R	S	T	Z
standard	con boccola di bronzo														
<b>CFIS032</b>	<b>CFKS032</b>	32	32.5	9	26	6.6	5	10	45	10	5.5	11	30	45	22
<b>CFIS040</b>	<b>CFKS040</b>	40	38	9	28	6.6	5	12	52	12	5.5	11	35	52	25
<b>CFIS050</b>	<b>CFKS050</b>	50	46.5	11	32	9	5	12	65	12	6.5	15	40	60	27
<b>CFIS063</b>	<b>CFKS063</b>	63	56.5	11	40	9	5	16	75	16	6.5	15	45	70	32
<b>CFIS080</b>	<b>CFKS080</b>	80	72	14	50	11	5	16	95	16	10	18	45	90	36
<b>CFIS100</b>	<b>CFKS100</b>	100	89	14	60	11	5	20	115	20	10	18	55	110	41
<b>CFIS125</b>	<b>CFKS125</b>	125	110	20	70	14	7	25	140	25	10	20	60	130	50
<b>CFIS160</b>	<b>CFKS160</b>	160	140	20	90	18	7	30	180	25	10	26	65	170	55
<b>CFIS200</b>	<b>CFKS200</b>	200	175	25	90	18	7	30	220	25	11	26	75	170	60

## FLANGIA

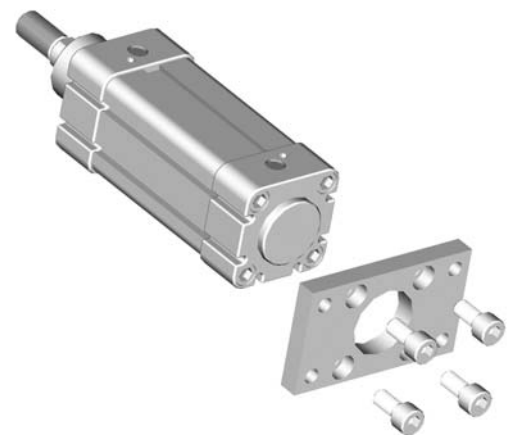
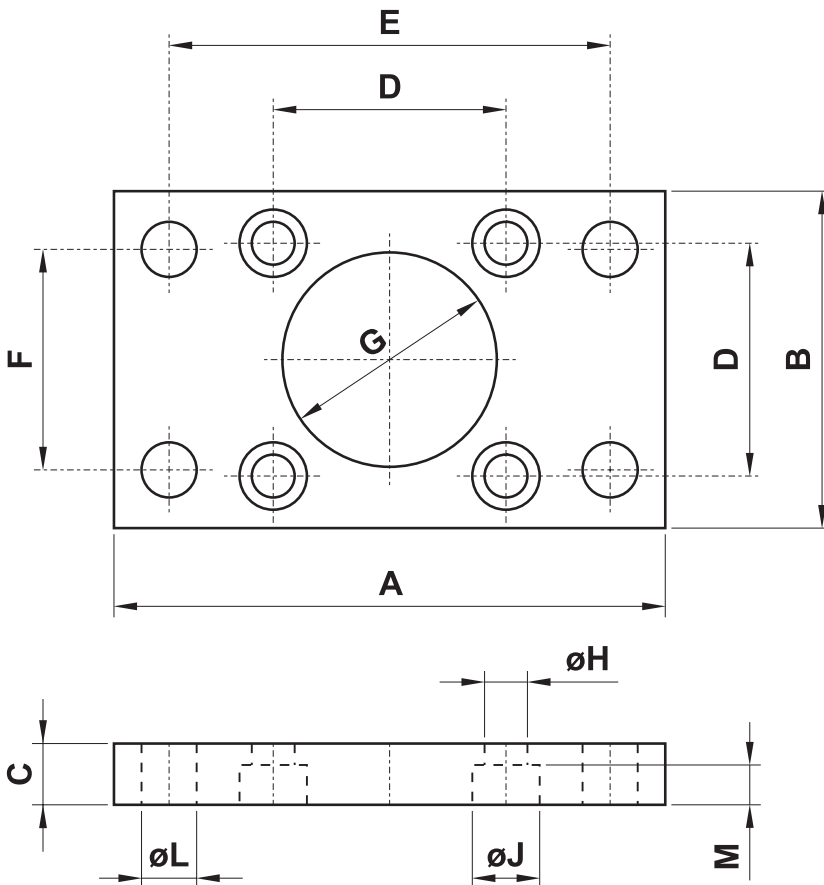

sigla part number	per alesaggio for bore	A	B	C	D	E	F	G	H	J	L	M
<b>FLIS032</b>	32	80	45	10	32.5	64	32	ø30	6.6	10.5	7	6.5
<b>FLIS040</b>	40	90	52	10	38	72	36	ø35	6.6	11	9	6.5
<b>FLIS050</b>	50	110	65	12	46.5	90	45	ø40	9	15	9	8.5
<b>FLIS063</b>	63	120	75	12	56.5	100	50	ø45	9	15	9	8.5
<b>FLIS080</b>	80	150	95	16	72	126	63	ø45	11	18	12	10.5
<b>FLIS100</b>	100	170	115	16	89	150	75	ø55	11	18	14	10.5
<b>FLIS125</b>	125	205	140	20	110	180	90	ø60	13.5	20	16	12.5
<b>FLIS160</b>	160	260	180	20	140	230	115	ø65	18	26	18	16.5
<b>FLIS200</b>	200	300	220	25	175	270	135	ø75	18	26	22	16.5

## PIEDINO

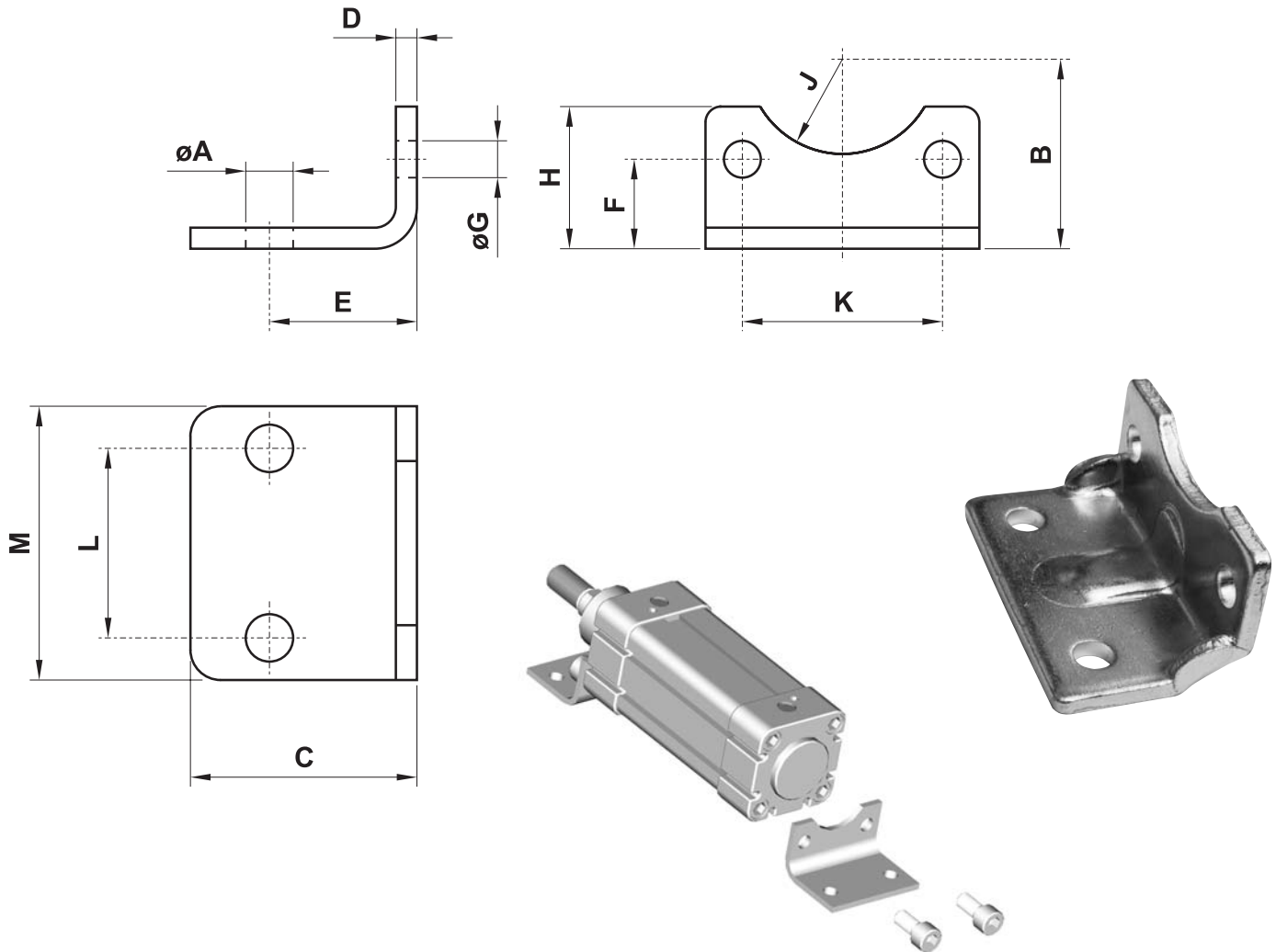

sigla* part number*	per alesaggio for bore	A	B	C	D	E	F	G	H	J	K	L	M
<b>PBIS032</b>	32	7	32	35	4	24	15.75	7	30	15	32.5	32	45
<b>PBIS040</b>	40	9	36	36	4	28	17	7	30	17.5	38	36	52
<b>PBIS050</b>	50	9	45	47	5	32	21.75	9	36	20	46.5	45	65
<b>PBIS063</b>	63	9	50	45	5	32	21.75	9	35	22.5	56.5	50	75
<b>PBIS080</b>	80	12	63	55	6	41	27	11	47	22.5	72	63	95
<b>PBIS100</b>	100	14	71	57	6	41	26.5	11	53	27.5	89	75	115
<b>PBIS125</b>	125	16	90	70	8	45	35	14	70	30	110	90	140
<b>PBIS160</b>	160	18	115	75	9	60	45	18	100	32.5	140	115	180
<b>PBIS200</b>	200	22	135	100	12	70	47.5	18	100	37.5	175	135	220

\* La sigla si riferisce a un solo piedino e non alla coppia

\* The part number is referred to only one element and not to the couple

## CERNIERA INTERMEDIA PER ESTRUSO

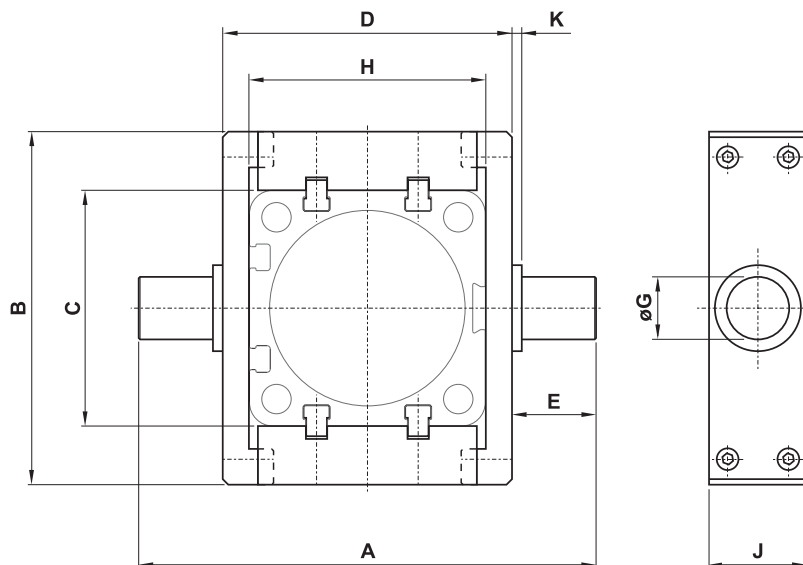

**alesaggi: 32, 40, 50**

*bores: 32, 40, 50*

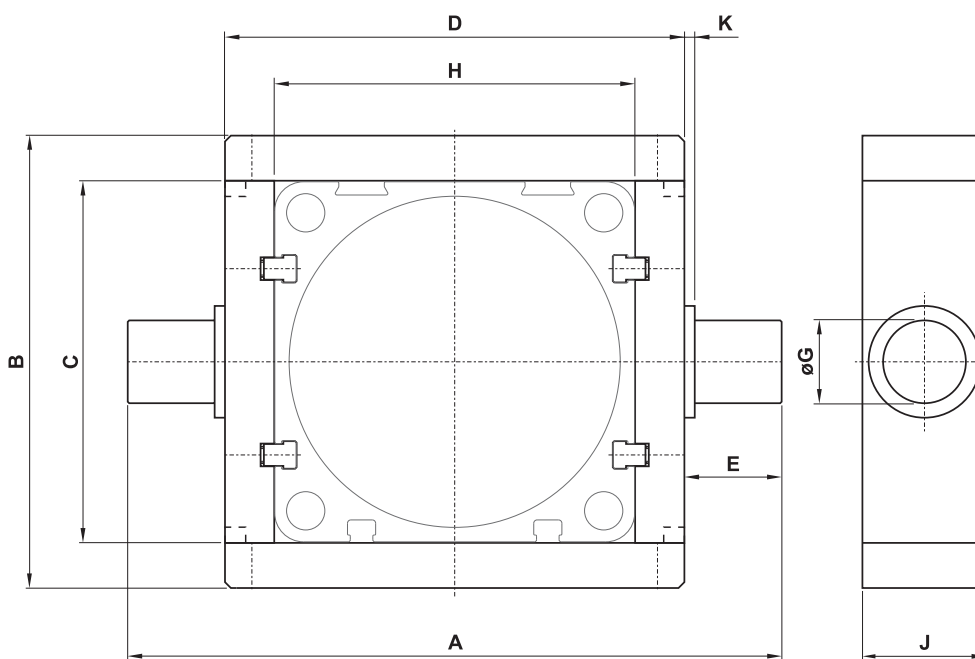

**alesaggi: 63, 80, 100, 125**

*bores: 63, 80, 100, 125*

sigla part number	per alesaggio for bore	A	B	C	D	E	G	H	J	K
<b>CIN032</b>	32	87	65	44.5	52	17.5	12	45	25	2
<b>CIN040</b>	40	105	74.8	50.5	62	21.5	16	50.8	25	2.5
<b>CIN050</b>	50	117	90.3	60.3	74	21.5	16	60.6	25	2.5
<b>CIN063</b>	63	136	94.5	70.5	91	22.5	20	70	30	2.5
<b>CIN080</b>	80	156	109.3	87.5	111	22.5	20	87	30	2.5
<b>CIN100</b>	100	195	134	106.6	129	33	25	106	40	2.5
<b>CIN125</b>	125	222.7	160	132.6	156.7	33	25	132	40	2.5

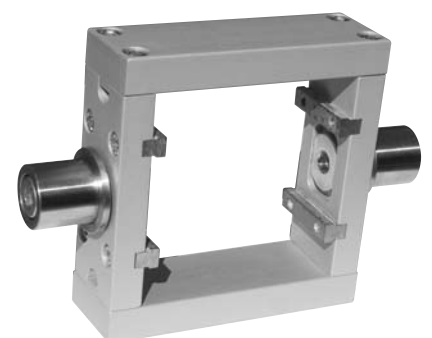

## SNODO PER CERNIERA INTERMEDIA

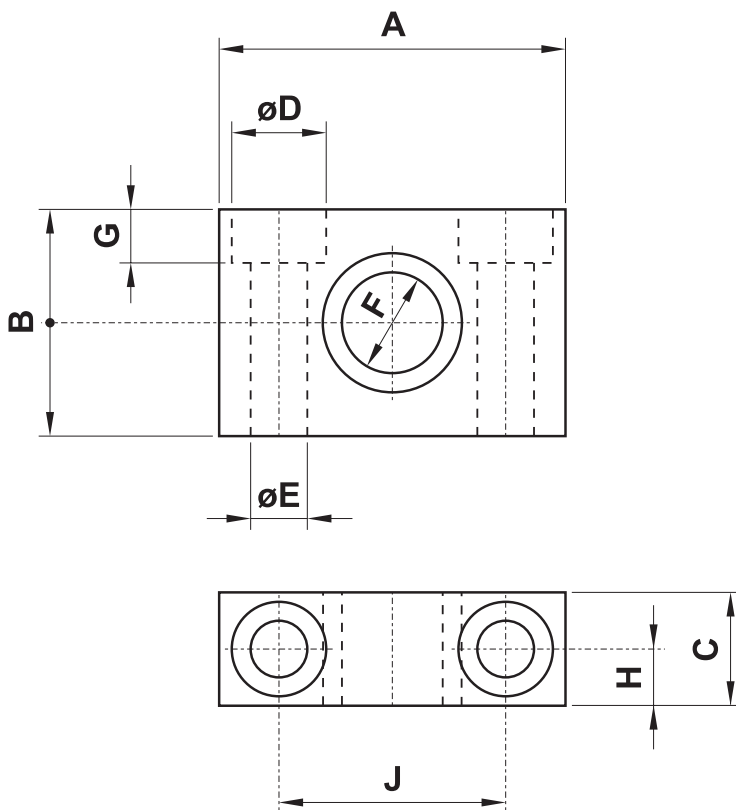

sigla* part number*	per alesaggio for bore	A	B	C	D	E	F	G	H	J
<b>SNINT 032 B</b>	32	46	30	15	10.5	6.5	∅12	6.5	7.5	32
<b>SNINT 040-050 B</b>	40-50	55	35	20	14	9	∅16	8	10	36
<b>SNINT 063-080 B</b>	63-80	65	40	20	17	11	∅20	12	10	42
<b>SNINT 100-125 B</b>	100-125	75	50	30	19	14	∅25	10	15	50

\* La sigla si riferisce a una coppia di snodi

\* The part number is referred to a couple of elements

## CERNIERA INTERMEDIA per cilindri da alesaggio 160 e 200 versione a tiranti

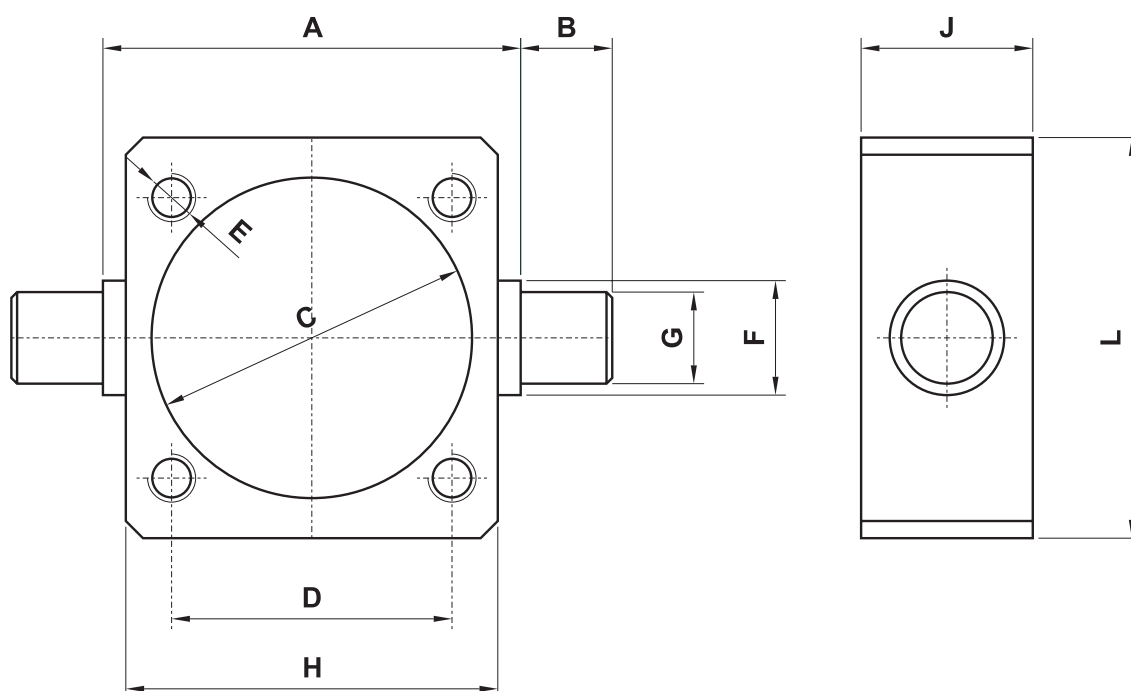

Questa cerniera intermedia può essere montata solo su cilindri a tubo tondo con tiranti. Al momento dell'ordine dei cilindri specificare chiaramente questa caratteristica, fornendo anche precise indicazioni riguardo alla posizione di montaggio della cerniera sul cilindro.

*This fixing element can be mounted only on a cylinder with round barrel and tie-rods. The request for cylinders with tie-rods must be clearly specified on the order. On the order please specify also the position where the fixing element should be mounted on the cylinder.*

sigla part number	per alesaggio for bore	A	B	C	D	E	G	H	J	L
<b>CSIS160TI</b>	160	200	32	∅170	140	M16	∅32	190	40	190
<b>CSIS200TI</b>	200	250	32	∅211	175	M16	∅32	240	40	240

## CONTROCERNIERA ORIZZONTALE A BASE RETTANGOLARE

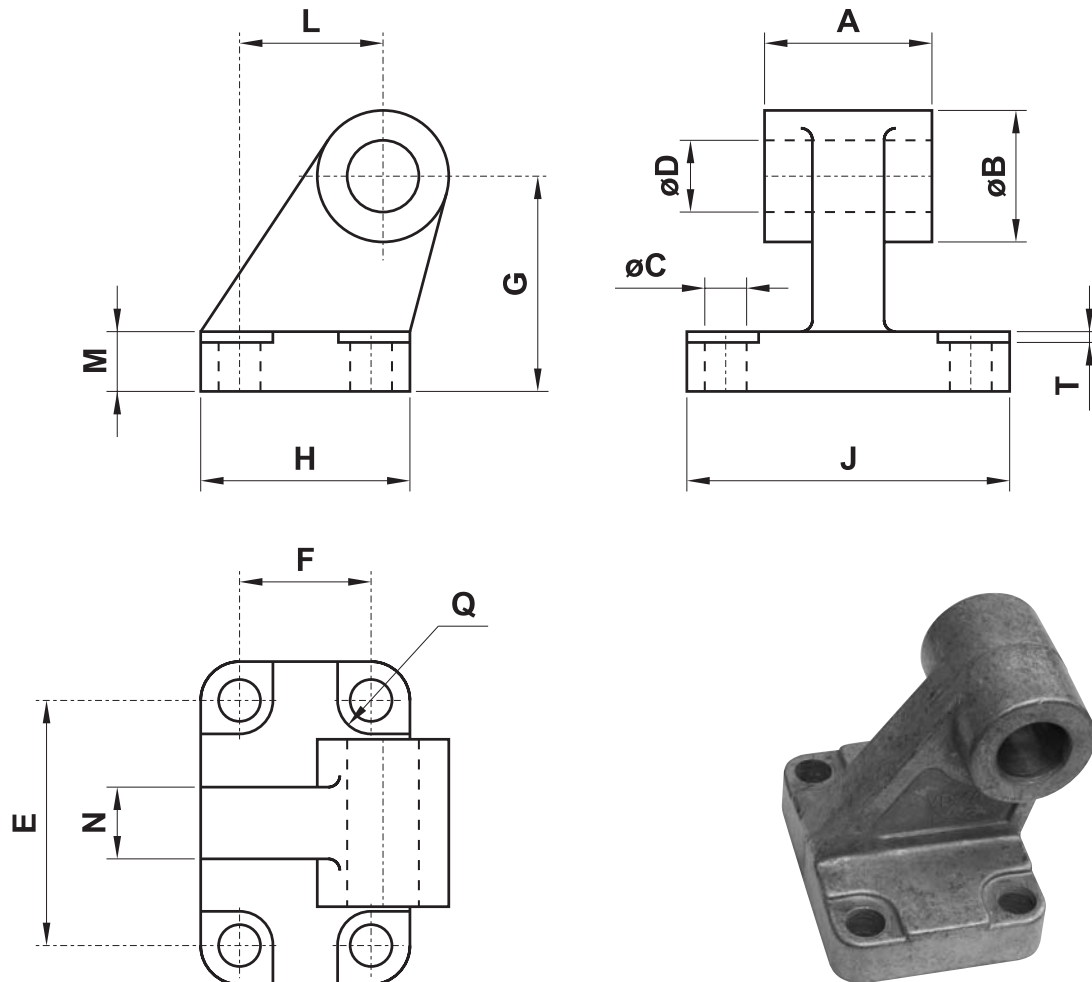

sigla part number	per alesaggio for bore	A	B	C	D	E	F	G	H	J	L	M	N	Q	T
<b>COIS032</b>	32	26	20	6.6	10	38	18	32	31	51	21	8	10	6.6	1.6
<b>COIS040</b>	40	28	22	6.6	12	41	22	36	35	54	24	10	15	6.6	1.6
<b>COIS050</b>	50	32	26	9	12	50	30	45	45	65	33	12	16	9	1.6
<b>COIS063</b>	63	40	30	9	16	52	35	50	50	67	37	14	16	9	1.6
<b>COIS080</b>	80	50	30	11	16	66	40	63	60	86	47	14	20	11	2.5
<b>COIS100</b>	100	60	38	11	20	76	50	71	70	96	55	17	20	11	2.5
<b>COIS125</b>	125	70	45	14	25	94	60	90	90	124	70	20	30	14	3.2
<b>COIS160</b>	160	90	63	14	30	118	88	115	126	156	97	25	36	14	4
<b>COIS200</b>	200	90	63	18	30	122	90	135	130	162	105	30	40	18	4



# fissaggi per cilindri ISO 6431 VDMA

fixing elements for cylinders ISO 6431 VDMA



## CERNIERA MASCHIO SNODO SFERICO

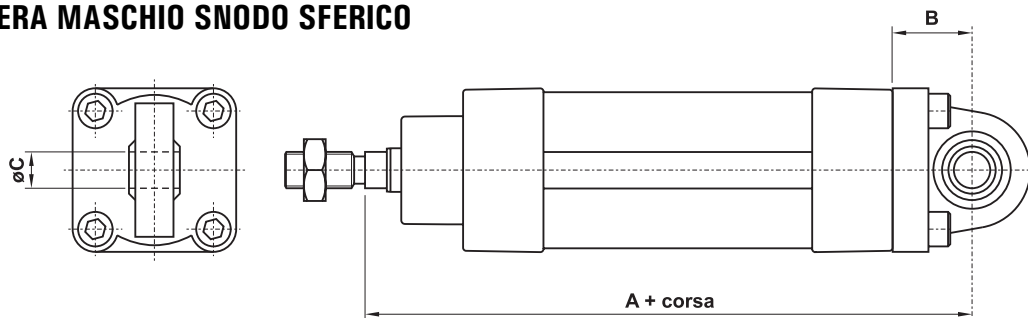

CMSS...

## CERNIERA MASCHIO

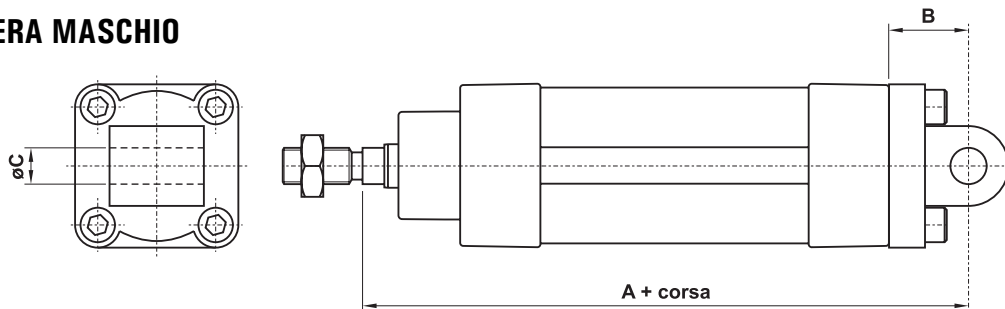

CMIS...

CMKS...

## CERNIERA FEMMINA CON PERNO

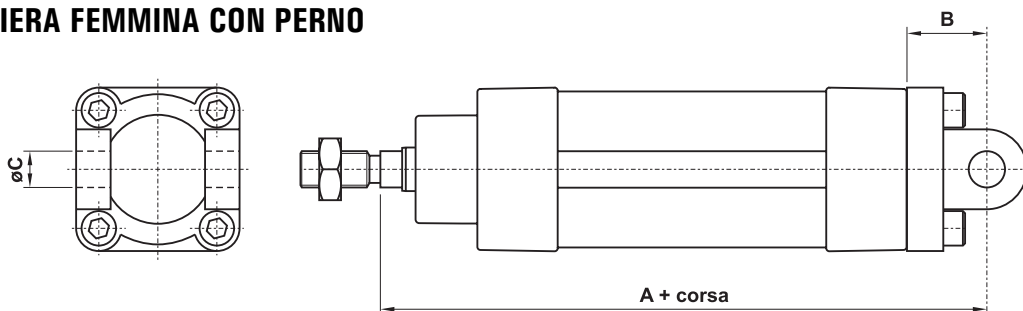

CFIS...

CFKS...

## PIEDINO

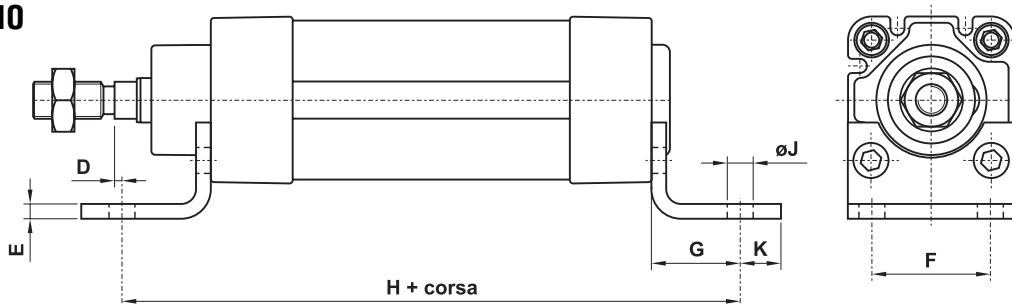

PBIS...

Ø	A	B	C	D	E	F	G	H	J	K
32	142	22	10	2	4	32	24	142	7	11
40	160	25	12	2	4	36	28	161	9	8
50	170	27	12	5	5	45	32	170	9	15
63	190	32	16	5	5	50	32	185	9	13
80	210	36	16	5	6	63	41	210	12	14
100	230	41	20	10	6	75	41	220	14	16
125	275	50	25	20	8	90	45	250	16	25
160	315	55	30	20	9	115	60	300	18	15
200	335	60	30	25	12	135	70	320	22	30

# fissaggi per cilindri ISO 6431 VDMA

fixing elements for cylinders ISO 6431 VDMA



## CERNIERA INTERMEDIA PER ESTRUSO

CIN...  
CSIS...TI

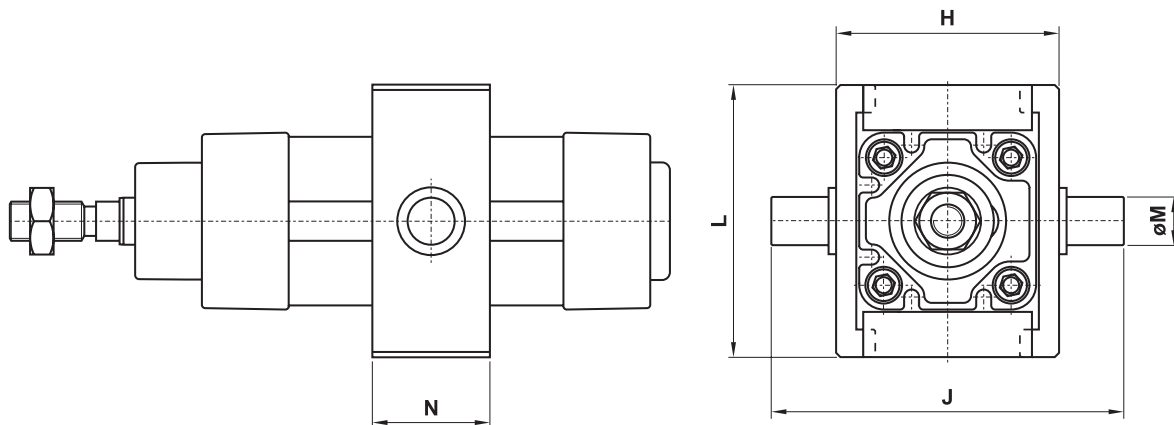

## FLANGIA

FLIS...

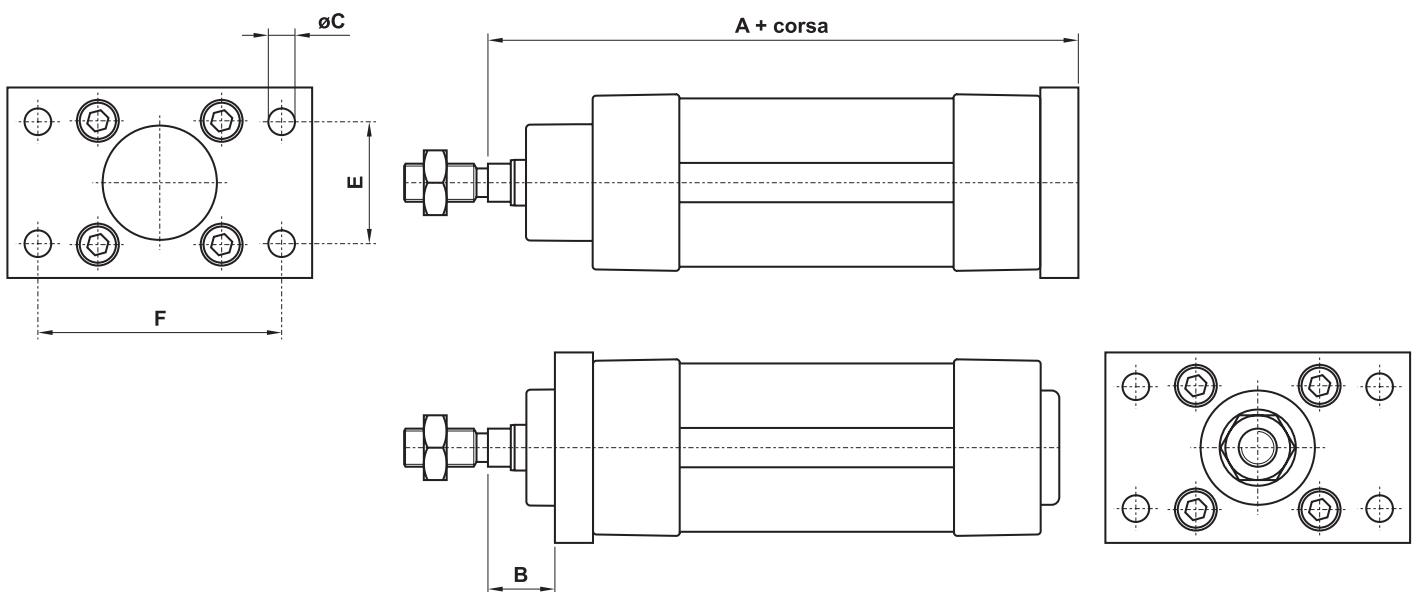

Ø	A	B	C	E	F	H	J	L	M	N
32	130	16	7	32	64	52	87	65	12	25
40	145	20	9	36	72	62	105	74.8	16	25
50	155	25	9	45	90	74	117	90.3	16	25
63	170	25	9	50	100	91	136	94.5	20	30
80	190	30	12	63	126	111	156	109.3	20	30
100	205	35	14	75	150	129	195	134	25	40
125	245	45	16	90	180	156.7	222.7	160	25	40
160	280	60	18	115	230	190	262	200	32	40
200	300	70	22	135	270	240	312	250	32	40

# cilindri compatti

compact cylinders



- Cilindri compatti con interasse ISO 6431 o UNITOP  
*Fixing dimensions are compliant to norm ISO 6431 or UNITOP*
- Predisposti per i fissaggi normalizzati  
*To be installed with standard fixing elements*
- Grande affidabilità e lunga durata  
*High reliability and long life time*
- Versione magnetica standard  
*Standard magnetic version*
- Esecuzioni e corse speciali a richiesta  
*Special versions and strokes on request*

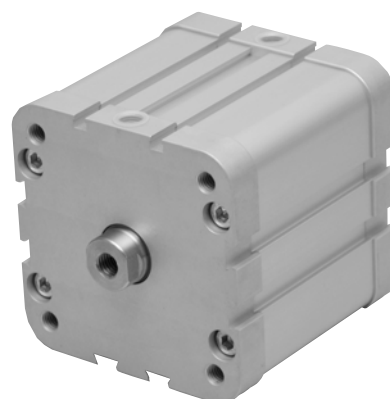

## Materiali

Camicia: alluminio

Stelo: C45 cromato o INOX AISI 304

Testate: alluminio

Pistone: alluminio

Guarnizioni: NBR o VITON

Guarnizione stelo: poliuretano o VITON

Magnete: plastroferrite

## Materials

Barrel: aluminium

Piston-rod: C45 (chromium plated) or stainless steel

End-cups: aluminium

Piston: aluminium

Sealings: NBR or VITON

Piston-rod sealing: polyurethane or VITON

Magnet: magnetic iron compound

Pressione di esercizio <i>Working pressure</i>	max 10 bar max 1 MPa
Temperatura di esercizio <i>Temperature range</i>	NBR: max +60°C VITON: max +110°C
Alesaggi <i>Bores</i>	32; 40; 50; 63; 80; 100 mm
Tipo di costruzione <i>Construction type</i>	Profilo quadro con cava centrale e cave laterali <i>Square aluminium profile</i>
Corse <i>Strokes</i>	5 ... 200 mm
Fluido <i>Fluid</i>	Aria filtrata 50µ con o senza lubrificazione <i>50µ filtered, lubricated or non lubricated air</i>

## chiave di codifica

key to codes

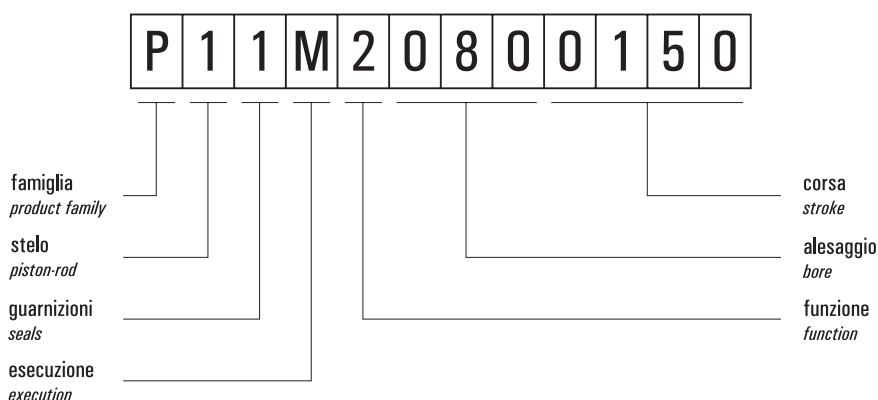

### Famiglia *[product family]*

- P** cilindri compatti interasse ISO 6431  
*[compact cylinders with fixing distances ISO 6431]*
- R** cilindri compatti interasse UNITOP  
*[compact cylinders with fixing distances UNITOP]*

### Stelo *[piston-rod]*

- 1** C45 cromato - filetto stelo femmina  
*[C45 chromium plated - female rod thread]*
- 2** INOX - filetto stelo femmina  
*[stainless steel - female rod thread]*
- 3** C45 cromato - filetto stelo maschio  
*[C45 chromium plated - male rod thread]*
- 4** INOX - filetto stelo maschio  
*[stainless steel - male rod thread]*

### Guarnizioni *[seals]*

- 1** NBR
- 2** tutte le guarnizioni in VITON *[all seals in VITON]*
- 3** guarnizioni dello stelo in VITON *[rod seals in VITON]*

### Esecuzione *[execution]*

- M** magnetico *[magnetic]*

### Funzione *[function]*

- 1** semplice effetto non ammortizzato molla anteriore  
*[single acting front spring without pneumatic cushioning]*
- 2** doppio effetto non ammortizzato  
*[double acting without pneumatic cushioning]*
- 3** semplice effetto non ammortizzato molla posteriore  
*[single acting back spring without pneumatic cushioning]*
- 4** doppio effetto non ammortizzato stelo passante  
*[double acting without pneumatic cushioning, with passing-through rod]*

## versioni disponibili

available versions

<b>semplice effetto molla anteriore</b> <i>single acting front spring</i> <b>magnetico</b> <i>magnetic</i> <b>non ammortizzato</b> <i>without pneumatic cushioning</i>	alesaggio		32	40	50	63	80	100	<b>OPZIONI</b> <i>options</i>  Lo standard è evidenziato in grigio <i>The standard is marked with grey background</i>				
	corsa	bore								stroke			
	5	X	X	X	X	X	X	X		<b>materiale stelo [piston-rod material]</b> C45 cromato <i>C45 chromium plated</i>	INOX <i>stainless steel</i>		
	10	X	X	X	X	X	X	X				<b>materiale guarnizioni [seals material]</b> NBR	tutte in VITON <i>all seals in VITON</i>
	25	X	X	X	X	X	X	X		<b>filetto stelo [rod thread]</b>			
	30			X	X	X	X	X		filetto stelo femmina <i>female rod thread</i>			
	40									filetto stelo maschio <i>male rod thread</i>			
	50												
	75												
	80												
	100												
	125												
	150												
	160												
	200												
	<b>semplice eff. molla posteriore</b> <i>single acting back spring</i> <b>magnetico</b> <i>magnetic</i> <b>non ammortizzato</b> <i>without pneumatic cushioning</i>	alesaggio		32	40	50	63	80	100	<b>OPZIONI</b> <i>options</i>  Lo standard è evidenziato in grigio <i>The standard is marked with grey background</i>			
corsa		bore	stroke										
		5	X	X	X	X	X	X	X		<b>materiale stelo [piston-rod material]</b> C45 cromato <i>C45 chromium plated</i>	INOX <i>stainless steel</i>	
		10	X	X	X	X	X	X	X				<b>materiale guarnizioni [seals material]</b> NBR
		25	X	X	X	X	X	X	X		<b>filetto stelo [rod thread]</b>		
		30			X	X	X	X	X		filetto stelo femmina <i>female rod thread</i>		
		40									filetto stelo maschio <i>male rod thread</i>		
		50											
		75											
		80											
		100											
		125											
		150											
		160											
	200												

4

## versioni disponibili

available versions

<b>doppio effetto</b> <i>double acting</i> <b>magnetico</b> <i>magnetic</i> <b>non ammortizzato</b> <i>without pneumatic cushioning</i>	alesaggio		32	40	50	63	80	100	<b>OPZIONI</b> <i>options</i>  Lo standard è evidenziato in grigio <i>The standard is marked with grey background</i>							
	corsa	bore														
	5	stroke	X	X	X	X	X	X	<b>materiale stelo [piston-rod material]</b>  <table border="1"> <tr> <td>C45 cromato <i>C45 chromium plated</i></td> <td>INOX <i>stainless steel</i></td> </tr> </table> <b>materiale guarnizioni [seals material]</b>  <table border="1"> <tr> <td>NBR</td> <td>tutte in VITON <i>all seals in VITON</i></td> <td>guarnizioni stelo in VITON <i>rod seals in VITON</i></td> </tr> </table> <b>filetto stelo [rod thread]</b>  <table border="1"> <tr> <td>filetto stelo femmina <i>female rod thread</i></td> <td>filetto stelo maschio <i>male rod thread</i></td> </tr> </table>	C45 cromato <i>C45 chromium plated</i>	INOX <i>stainless steel</i>	NBR	tutte in VITON <i>all seals in VITON</i>	guarnizioni stelo in VITON <i>rod seals in VITON</i>	filetto stelo femmina <i>female rod thread</i>	filetto stelo maschio <i>male rod thread</i>
	C45 cromato <i>C45 chromium plated</i>	INOX <i>stainless steel</i>														
	NBR	tutte in VITON <i>all seals in VITON</i>	guarnizioni stelo in VITON <i>rod seals in VITON</i>													
	filetto stelo femmina <i>female rod thread</i>	filetto stelo maschio <i>male rod thread</i>														
	10	X	X	X	X	X	X	X								
	25	X	X	X	X	X	X	X								
	30	X	X	X	X	X	X	X								
	40	X	X	X	X	X	X	X								
	50	X	X	X	X	X	X	X								
	75	X	X	X	X	X	X	X								
	80	X	X	X	X	X	X	X								
	100	X	X	X	X	X	X	X								
	125	X	X	X	X	X	X	X								
150	X	X	X	X	X	X	X									
160	X	X	X	X	X	X	X									
200	X	X	X	X	X	X	X									
<b>doppio effetto</b> <i>double acting</i> <b>magnetico</b> <i>magnetic</i> <b>non ammortizzato</b> <i>without pneumatic cushioning</i> <b>stelo passante</b> <i>passing-through rod</i>	alesaggio		32	40	50	63	80	100	<b>OPZIONI</b> <i>options</i>  Lo standard è evidenziato in grigio <i>The standard is marked with grey background</i>							
	corsa	bore														
	5	stroke	X	X	X	X	X	X	<b>materiale stelo [piston-rod material]</b>  <table border="1"> <tr> <td>C45 cromato <i>C45 chromium plated</i></td> <td>INOX <i>stainless steel</i></td> </tr> </table> <b>materiale guarnizioni [seals material]</b>  <table border="1"> <tr> <td>NBR</td> <td>tutte in VITON <i>all seals in VITON</i></td> <td>guarnizioni stelo in VITON <i>rod seals in VITON</i></td> </tr> </table> <b>filetto stelo [rod thread]</b>  <table border="1"> <tr> <td>filetto stelo femmina <i>female rod thread</i></td> <td>filetto stelo maschio <i>male rod thread</i></td> </tr> </table>	C45 cromato <i>C45 chromium plated</i>	INOX <i>stainless steel</i>	NBR	tutte in VITON <i>all seals in VITON</i>	guarnizioni stelo in VITON <i>rod seals in VITON</i>	filetto stelo femmina <i>female rod thread</i>	filetto stelo maschio <i>male rod thread</i>
	C45 cromato <i>C45 chromium plated</i>	INOX <i>stainless steel</i>														
	NBR	tutte in VITON <i>all seals in VITON</i>	guarnizioni stelo in VITON <i>rod seals in VITON</i>													
	filetto stelo femmina <i>female rod thread</i>	filetto stelo maschio <i>male rod thread</i>														
	10	X	X	X	X	X	X	X								
	25	X	X	X	X	X	X	X								
	30	X	X	X	X	X	X	X								
	40	X	X	X	X	X	X	X								
	50	X	X	X	X	X	X	X								
	75	X	X	X	X	X	X	X								
	80	X	X	X	X	X	X	X								
	100	X	X	X	X	X	X	X								
	125	X	X	X	X	X	X	X								
150	X	X	X	X	X	X	X									
160	X	X	X	X	X	X	X									
200	X	X	X	X	X	X	X									

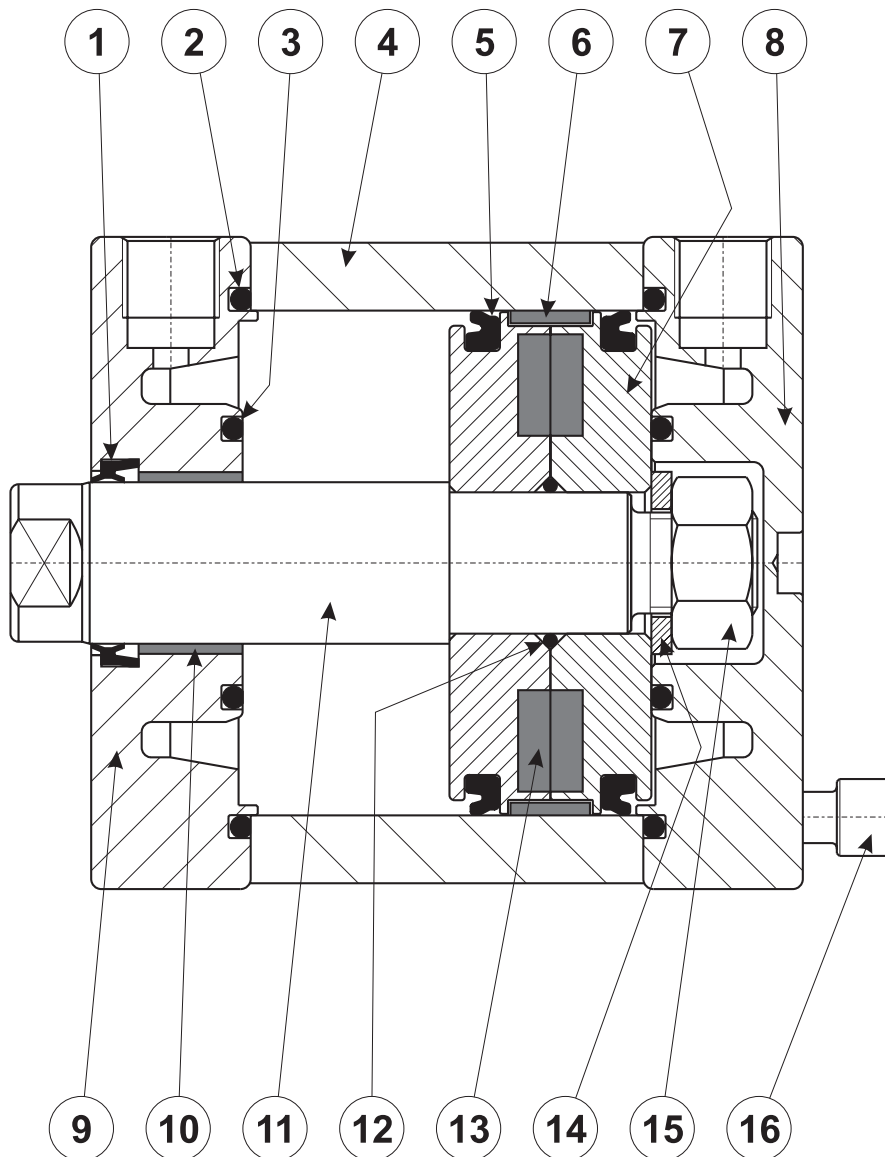

1. Guarnizione stelo: POLIURETANO o VITON
2. O-Ring per tenuta testata: NBR o VITON
3. O-Ring paracolpi: NBR o VITON
4. Camicia: alluminio profilato, calibrato e anodizzato
5. Guarnizione a labbro per pistone: NBR o VITON
6. Anello guida per pistone: bronzo PTFE
7. Pistone: alluminio
8. Testata posteriore: alluminio
9. Testata anteriore: alluminio
10. Boccola guida: materiale autolubrificante
11. Stelo: acciaio C45 cromato o INOX AISI 304
12. O-Ring per tenuta pistone: NBR o VITON
13. Magnete: plastoferrite
14. Rondella piana
15. Dado per bloccaggio stelo
16. Vite per fissaggio testata

## kit guarnizioni di ricambio

seals kit

## MAGNETICO, guarnizioni standard

normale			stelo passante <i>[passing-through rod]</i>		
per alesaggio <i>for bore</i>	sigla <i>part number</i>	codice <i>code</i>	per alesaggio <i>for bore</i>	sigla <i>part number</i>	codice <i>code</i>
32	<b>GP032</b>	25.103.2	32	<b>GP032P</b>	25.113.2
40	<b>GP040</b>	25.104.2	40	<b>GP040P</b>	25.114.2
50	<b>GP050</b>	25.105.2	50	<b>GP050P</b>	25.115.2
63	<b>GP063</b>	25.106.2	63	<b>GP063P</b>	25.116.2
80	<b>GP080</b>	25.107.2	80	<b>GP080P</b>	25.117.2
100	<b>GP100</b>	25.108.2	100	<b>GP100P</b>	25.118.2

## MAGNETICO, guarnizioni VITON

normale			stelo passante <i>[passing-through rod]</i>		
per alesaggio <i>for bore</i>	sigla <i>part number</i>	codice <i>code</i>	per alesaggio <i>for bore</i>	sigla <i>part number</i>	codice <i>code</i>
32	<b>GP032V</b>	25.123.2	32	<b>GP032PV</b>	25.133.2
40	<b>GP040V</b>	25.124.2	40	<b>GP040PV</b>	25.134.2
50	<b>GP050V</b>	25.125.2	50	<b>GP050PV</b>	25.135.2
63	<b>GP063V</b>	25.126.2	63	<b>GP063PV</b>	25.136.2
80	<b>GP080V</b>	25.127.2	80	<b>GP080PV</b>	25.137.2
100	<b>GP100V</b>	25.128.2	100	<b>GP100PV</b>	25.138.2



## VERSIONE MAGNETICA, FILETTO STELO FEMMINA

magnetic version, female rod thread

alesaggio 32  
bore 32

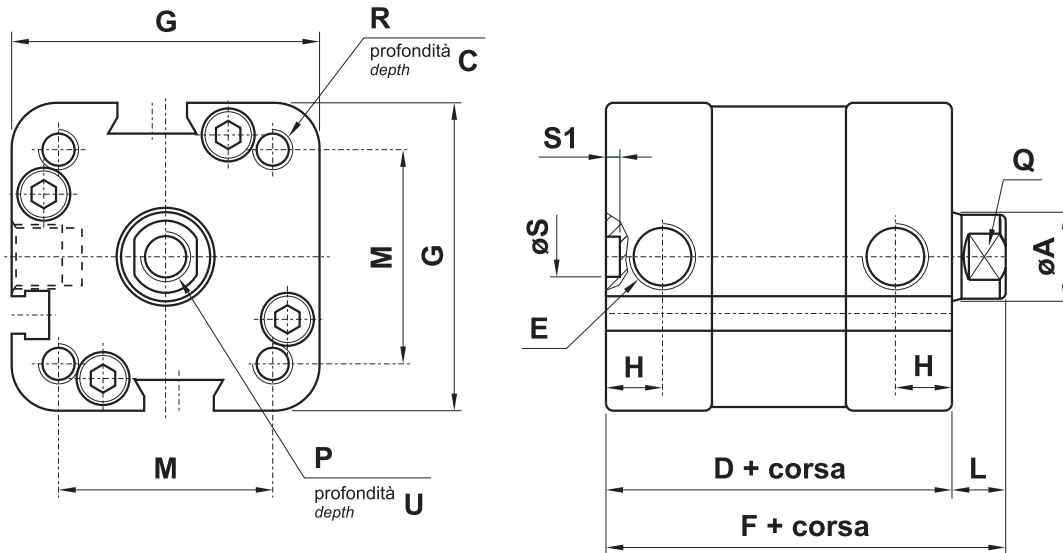

ø	A	C	D	E	F*	G		H	L*	M		P	Q	R		S	S1	U
						ISO	UNITOP			ISO	UNITOP			ISO	UNITOP			
32	12	14	46	G1/8"	53	46	46	7	7	32.3	32.3	M8	ch 10	M6	M6	6	2.5	13.5

4

alesaggio 40 - 50 - 63  
bore 40 - 50 - 63

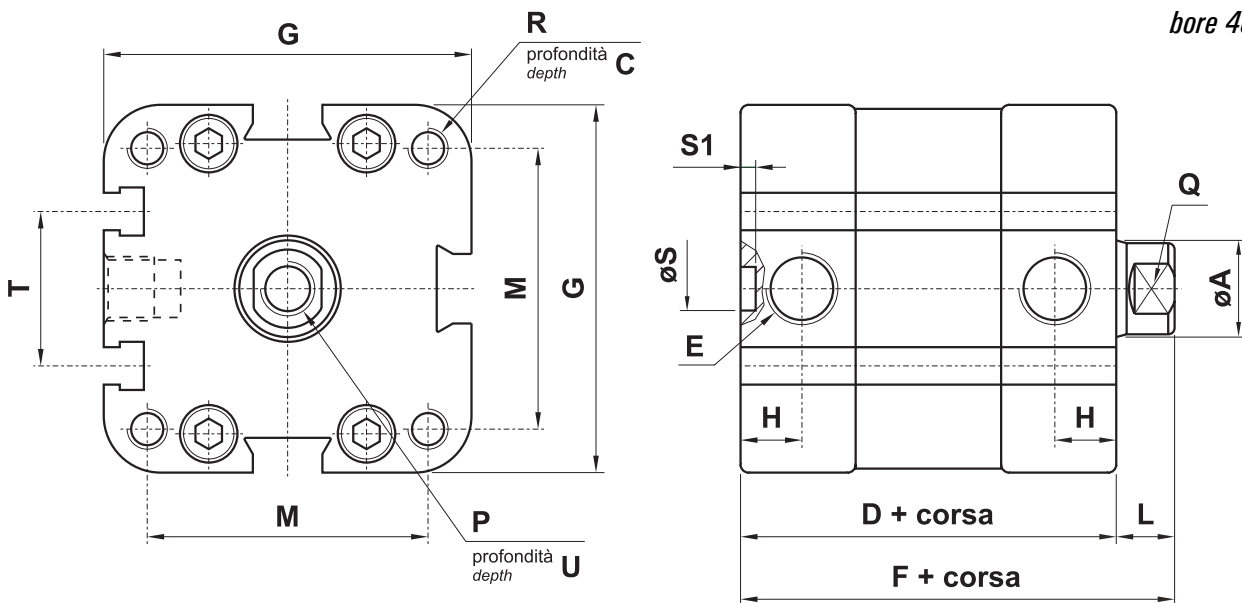

ø	A	C	D	E	F*	G		H	L*	M		P	Q	R		S	S1	T	U
						ISO	UNITOP			ISO	UNITOP			ISO	UNITOP				
40	12	14	46	G1/8"	53	55	55	6.5	7	38	42	M8	ch 10	M6	M6	6	2.5	22	13.5
50	16	15	50	G1/8"	58	64.5	64.5	7.5	8	46.5	50	M10	ch 13	M8	M8	6	2.5	24	16
63	16	15	53	G1/8"	61	78	78	7.5	8	56.5	62	M10	ch 13	M8	M10	6	2.5	29	16

# cilindri compatti

compact cylinders



alesaggio 80 - 100

bore 80 - 100

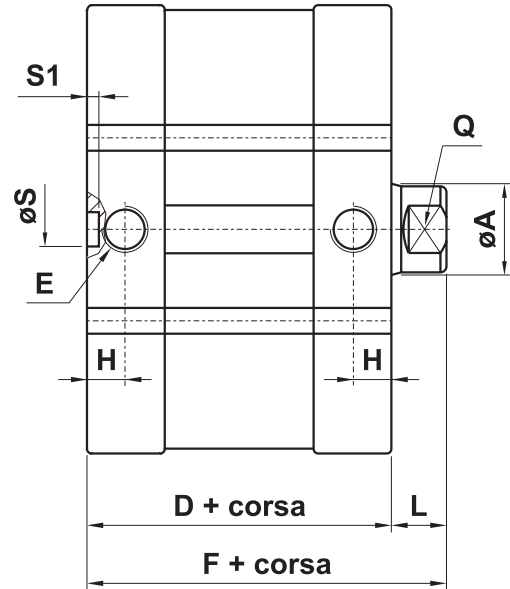
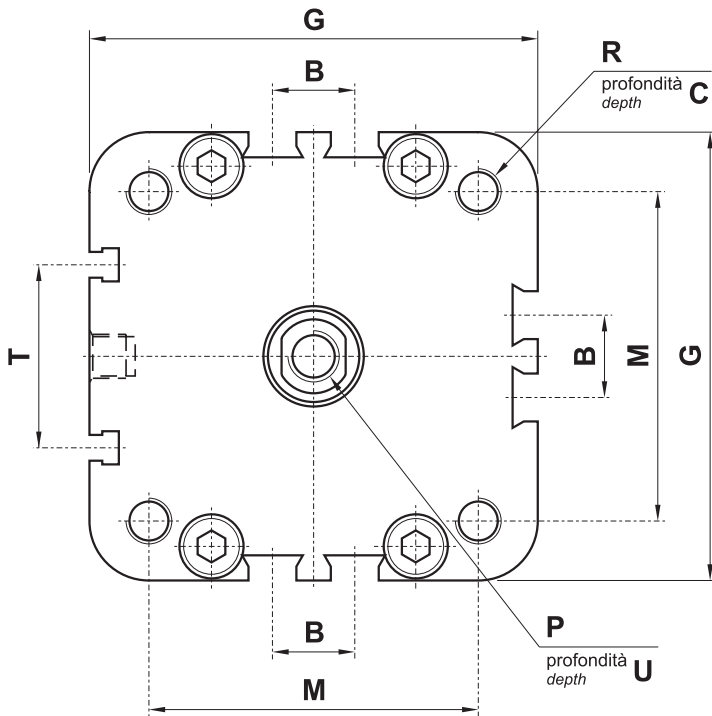

ø	A	B	C	D	E	F*	G		H	L*	M		P	Q	R		S	S1	T	U
							ISO	UNITOP			ISO	UNITOP			ISO	UNITOP				
80	20	18	17	56	G1/8"	66	98	99	8	10	72	82	M10	ch 17	M10	M10	8	3.5	40	20
100	25	28	17.5	67	G1/4"	77	117	119	9	10	89	103	M12	ch 22	M10	M10	8	4	40	24

F\*; L\*: In caso di cilindro semplice effetto molla posteriore aggiungere la lunghezza della corsa

F\*; L\*: In case of single acting cylinder with back spring add stroke length

## VERSIONE MAGNETICA, FILETTO STELO FEMMINA, STELO PASSANTE

magnetic version, female rod thread, passing-through rod

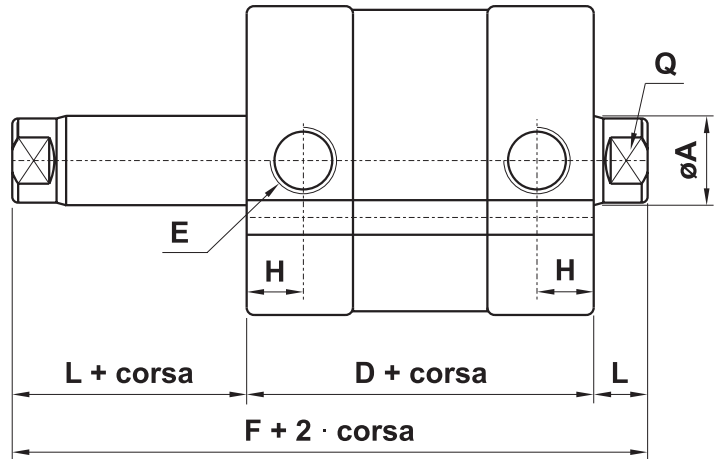
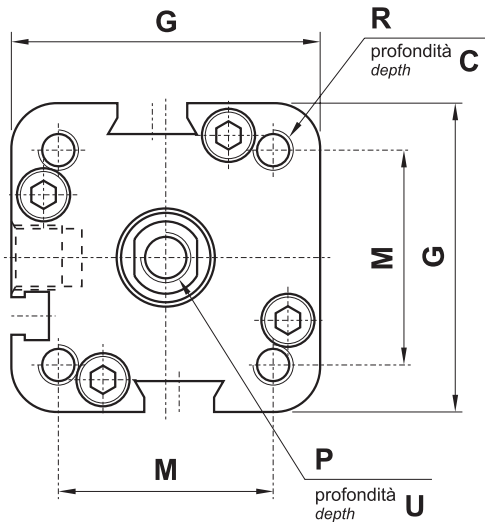

alesaggio 32  
bore 32

ø	A	C	D	E	F	G		H	L	M		P	Q	R		U
						ISO	UNITOP			ISO	UNITOP			ISO	UNITOP	
32	12	14	46	G1/8"	60	46	46	7	7	32.3	32.3	M8	ch 10	M6	M6	13.5

4

alesaggio 40 - 50 - 63

bore 40 - 50 - 63

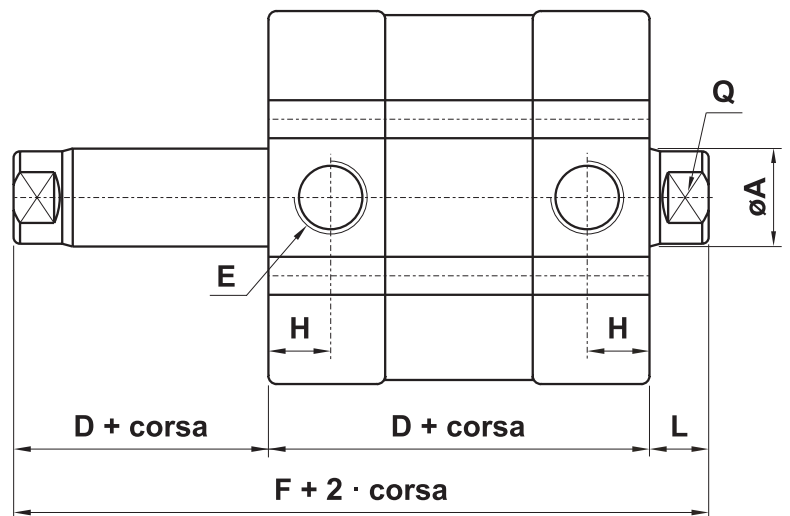
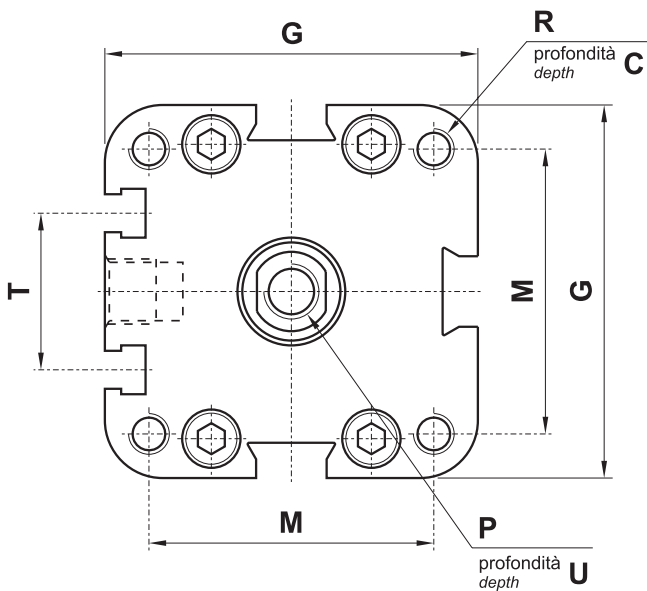

ø	A	C	D	E	F	G		H	L	M		P	Q	R		T	U
						ISO	UNITOP			ISO	UNITOP			ISO	UNITOP		
40	12	14	46	G1/8"	60	55	55	6.5	7	38	42	M8	ch 10	M6	M6	22	13.5
50	16	15	50	G1/8"	66	64.5	64.5	7.5	8	46.5	50	M10	ch 13	M8	M8	24	16
63	16	15	53	G1/8"	69	78	78	7.5	8	56.5	62	M10	ch 13	M8	M10	29	16

# cilindri compatti

compact cylinders



alesaggio 80 - 100

bore 80 - 100

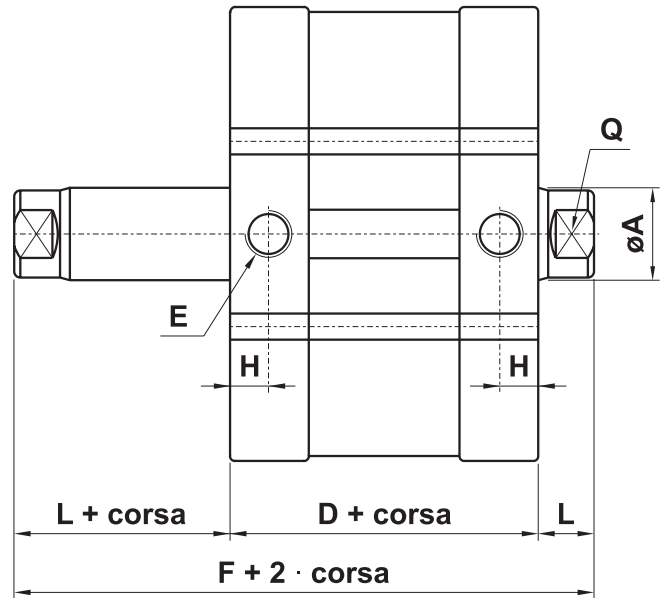
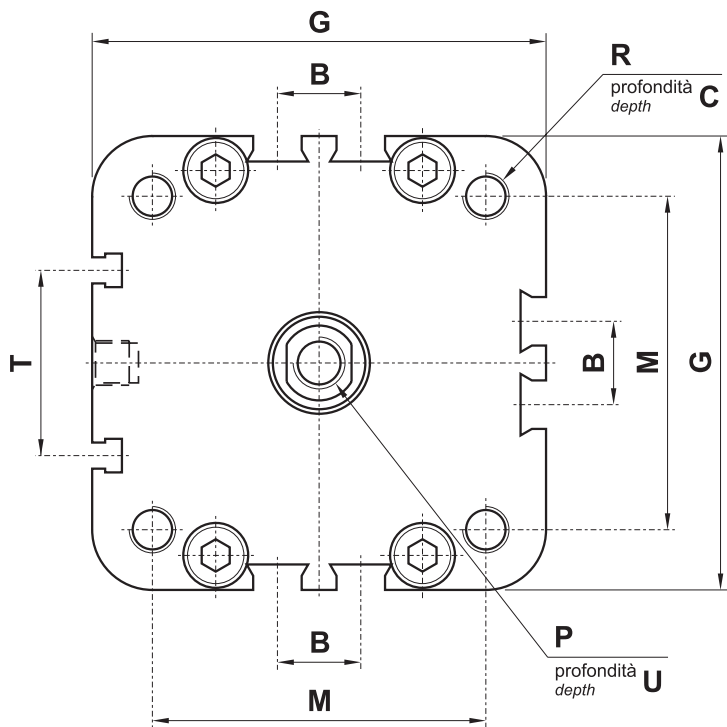

ø	A	B	C	D	E	F	G		H	L	M		P	Q	R		T	U
							ISO	UNITOP			ISO	UNITOP			ISO	UNITOP		
80	20	18	17	56	G1/8"	76	98	99	8	10	72	82	M10	ch 17	M10	M10	40	20
100	25	28	17.5	67	G1/4"	87	117	119	9	10	89	103	M12	ch 22	M10	M10	40	24

## VERSIONE MAGNETICA, FILETTO STELO MASCHIO

magnetic version, male rod thread

alesaggio 32  
bore 32

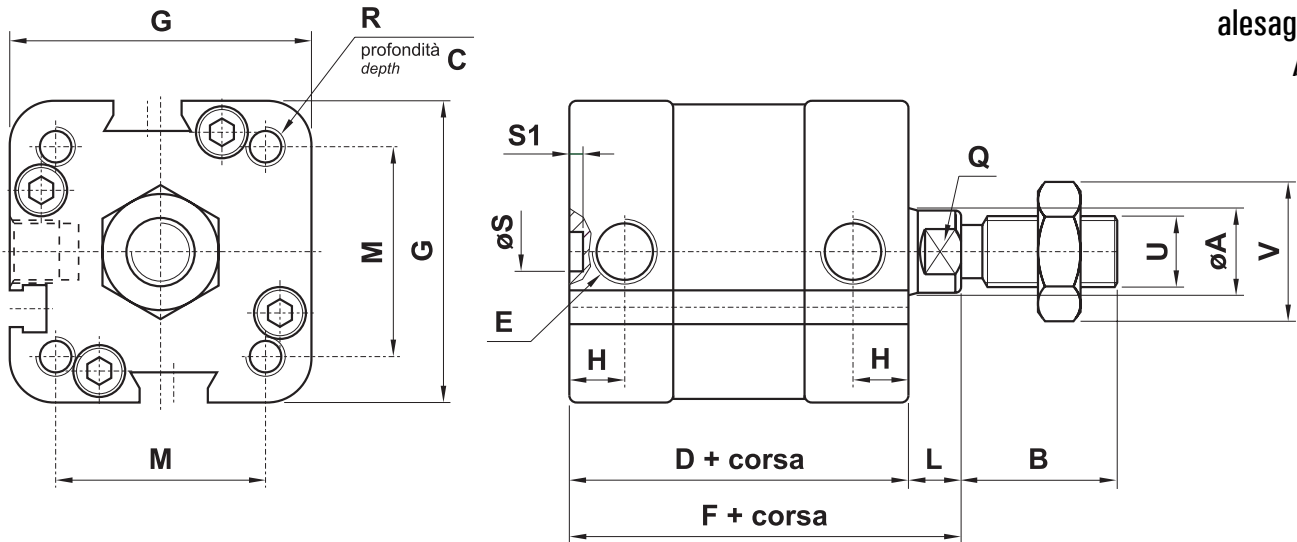

ø	A	B	C	D	E	F*	G		H	L*	M		Q	R		S	S1	U	V
							ISO	UNITOP			ISO	UNITOP		ISO	UNITOP				
32	12	22	14	46	G1/8"	53	46	46	7	7	32.3	32.3	ch 10	M6	M6	6	2.5	M10x1.25	ch 17

4

alesaggio 40 - 50 - 63  
bore 40 - 50 - 63

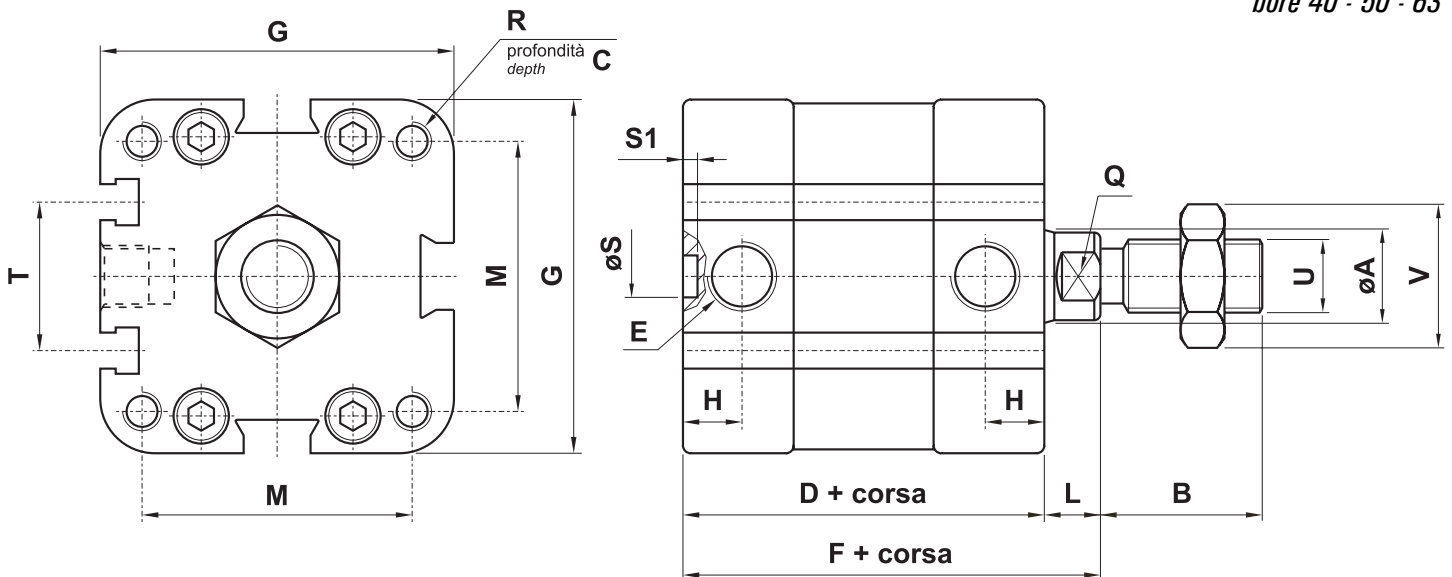

ø	A	B	C	D	E	F*	G		H	L*	M		Q	R		S	S1	T	U	V
							ISO	UNITOP			ISO	UNITOP		ISO	UNITOP					
40	12	22	14	46	G1/8"	53	55	55	6.5	7	38	42	ch 10	M6	M6	6	2.5	22	M10x1.25	ch 17
50	16	24	15	50	G1/8"	58	64.5	64.5	7.5	8	46.5	50	ch 13	M8	M8	6	2.5	24	M12x1.25	ch 19
63	16	24	15	53	G1/8"	61	78	78	7.5	8	56.5	62	ch 13	M8	M10	6	2.5	29	M12x1.25	ch 19

# cilindri compatti

compact cylinders



alesaggio 80 - 100

bore 80 - 100

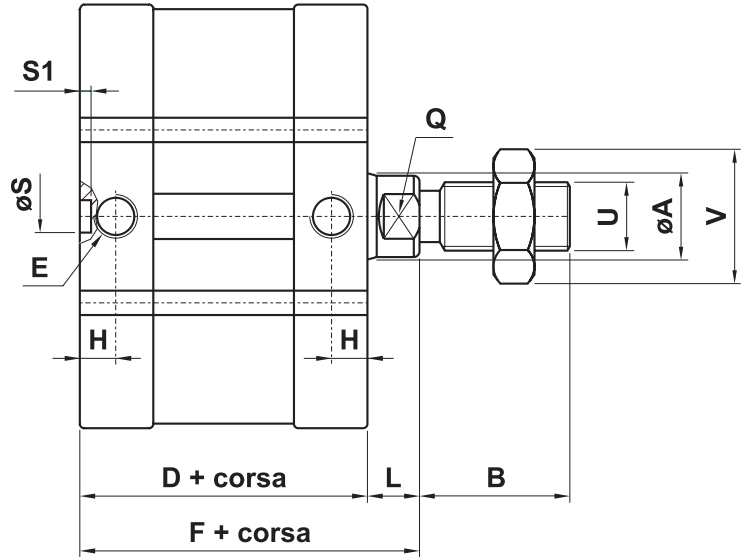
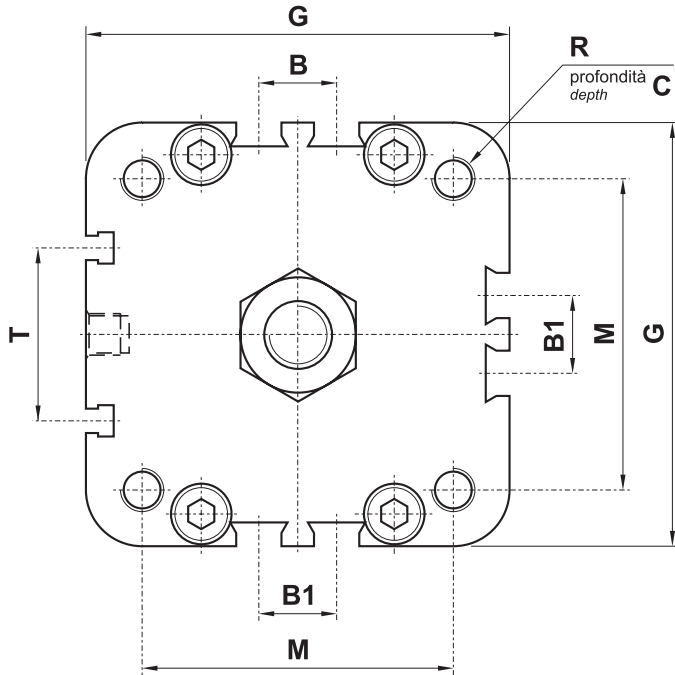

ø	A	B	B1	C	D	E	F*	G		H	L*	M		Q	R		S	S1	T	U	V
								ISO	UNITOP			ISO	UNITOP		ISO	UNITOP					
80	20	32	18	17	56	G1/8"	66	98	99	8	10	72	82	ch 17	M10	M10	8	3.5	40	M16x1.5	ch 24
100	25	40	28	17.5	67	G1/4"	77	117	119	9	10	89	103	ch 22	M10	M10	8	4	40	M20x1.5	ch 30

F\*; L\*: In caso di cilindro semplice effetto molla posteriore aggiungere la lunghezza della corsa

F\*; L\*: In case of single acting cylinder with back spring add stroke length

## VERSIONE MAGNETICA, FILETTO STELO MASCHIO, STELO PASSANTE

magnetic version, male rod thread, passing-through rod

alesaggio 32  
bore 32

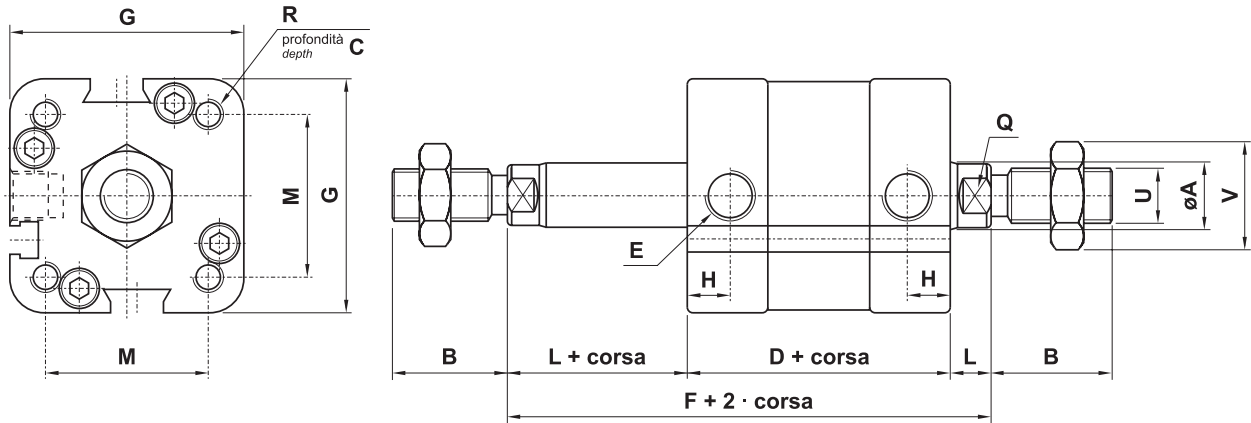

ø	A	B	C	D	E	F	G		H	L	M		Q	R		U	V
							ISO	UNITOP			ISO	UNITOP		ISO	UNITOP		
32	12	22	14	46	G1/8"	60	46	46	7	7	32.3	32.3	ch 10	M6	M6	M10x1.25	ch 17

alesaggio 40 - 50 - 63  
bore 40 - 50 - 63

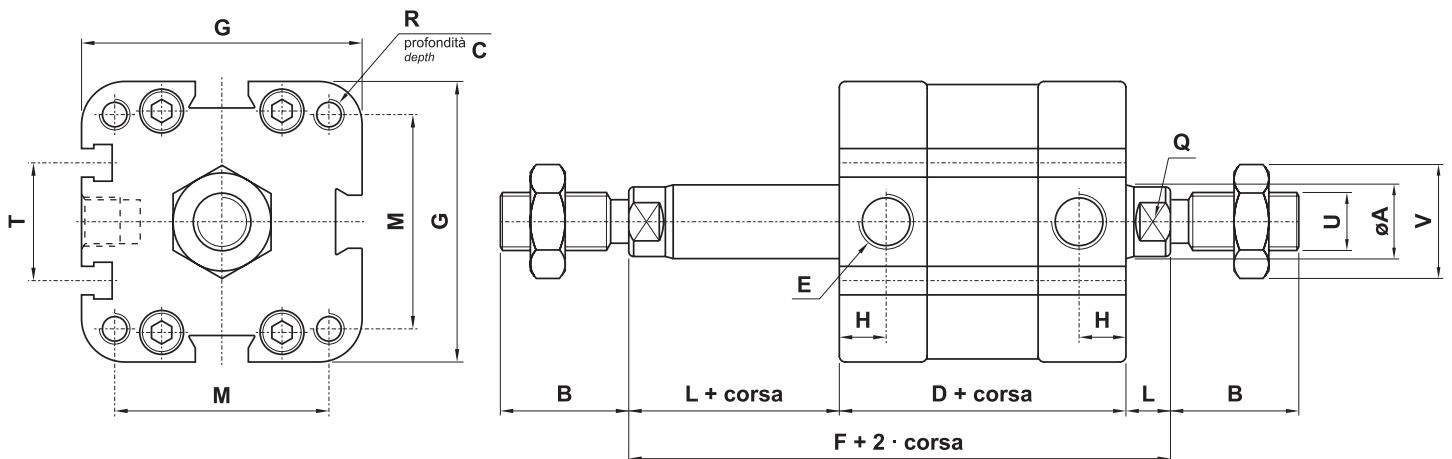

ø	A	B	C	D	E	F	G		H	L	M		Q	R		T	U	V
							ISO	UNITOP			ISO	UNITOP		ISO	UNITOP			
40	12	22	14	46	G1/8"	60	55	55	6.5	7	38	42	ch 10	M6	M6	22	M10x1.25	ch 17
50	16	24	15	50	G1/8"	66	64.5	64.5	7.5	8	46.5	50	ch 13	M8	M8	24	M12x1.25	ch 19
63	16	24	15	53	G1/8"	69	78	78	7.5	8	56.5	62	ch 13	M8	M10	29	M12x1.25	ch 19

# cilindri compatti

compact cylinders



alesaggio 80 - 100

bore 80 - 100

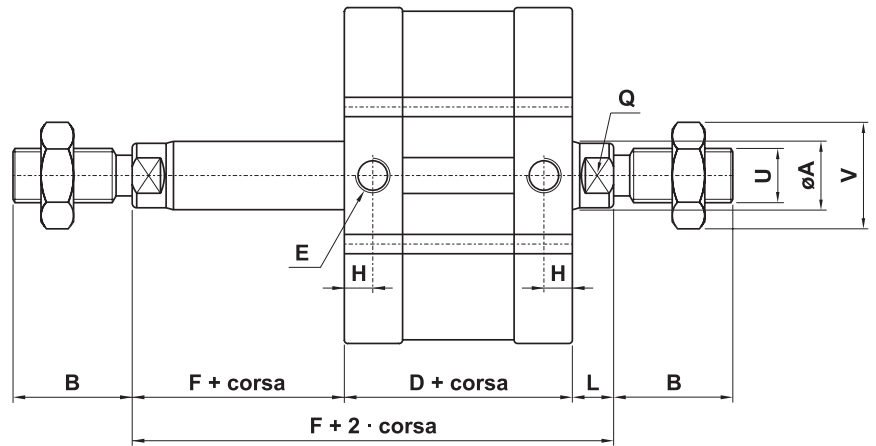
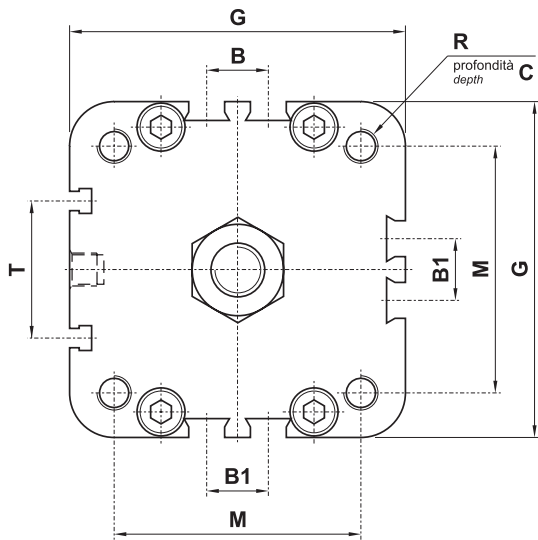

ø	A	B	B1	C	D	E	F	G		H	L	M		Q	R		T	U	V
								ISO	UNITOP			ISO	UNITOP		ISO	UNITOP			
80	20	32	18	17	56	G1/8"	76	98	99	8	10	72	82	ch 17	M10	M10	40	M16x1.5	ch 24
100	25	40	28	17.5	67	G1/4"	87	117	119	9	10	89	103	ch 22	M10	M10	40	M20x1.5	ch 30



## kit cilindro compatto

compact cylinder kit

### Il kit comprende:

- testate premontate
- pistone con magnete, guarnizioni e anello di guida
- viti
- tutte le guarnizioni necessarie

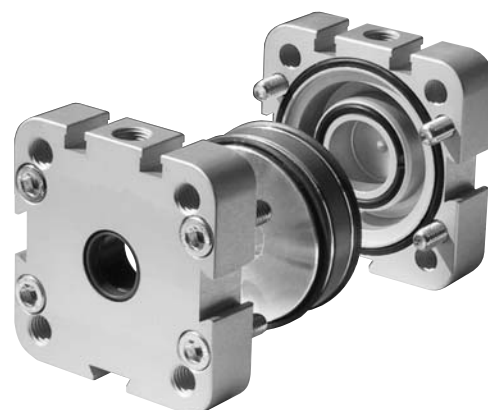

### MAGNETICO, guarnizioni standard

normale					stelo passante [passing-through rod]				
per alesaggio for bore	ISO		UNITOP		per alesaggio for bore	ISO		UNITOP	
	sigla part number	codice code	sigla part number	codice code		sigla part number	codice code	sigla part number	codice code
32	KP032	25.004.3	KR032	25.104.3	32	KP032P	25.014.3	KR032P	25.114.3
40	KP040	25.005.3	KR040	25.105.3	40	KP040P	25.015.3	KR040P	25.115.3
50	KP050	25.006.3	KR050	25.106.3	50	KP050P	25.016.3	KR050P	25.116.3
63	KP063	25.007.3	KR063	25.107.3	63	KP063P	25.017.3	KR063P	25.117.3
80	KP080	25.008.3	KR080	25.108.3	80	KP080P	25.018.3	KR080P	25.118.3
100	KP100	25.009.3	KR100	25.109.3	100	KP100P	25.019.3	KR100P	25.119.3

### MAGNETICO, guarnizioni VITON

normale					stelo passante [passing-through rod]				
per alesaggio for bore	ISO		UNITOP		per alesaggio for bore	ISO		UNITOP	
	sigla part number	codice code	sigla part number	codice code		sigla part number	codice code	sigla part number	codice code
32	KP032V	25.024.3	KR032V	25.124.3	32	KP032PV	25.034.3	KR032PV	25.134.3
40	KP040V	25.025.3	KR040V	25.125.3	40	KP040PV	25.035.3	KR040PV	25.135.3
50	KP050V	25.026.3	KR050V	25.126.3	50	KP050PV	25.036.3	KR050PV	25.136.3
63	KP063V	25.027.3	KR063V	25.127.3	63	KP063PV	25.037.3	KR063PV	25.137.3
80	KP080V	25.028.3	KR080V	25.128.3	80	KP080PV	25.038.3	KR080PV	25.138.3
100	KP100V	25.029.3	KR100V	25.129.3	100	KP100PV	25.039.3	KR100PV	25.139.3

Maggiori informazioni sono disponibili all'indirizzo internet <http://www.azpneumatica.com/azweb/ita/kitcilc.htm>

More information is available at the internet address <http://www.azpneumatica.com/azweb/ita/kitcilc.htm>

# barre per camicia cilindri compatti

barrel for compact cylinders



	codice di ordinazione order code	dimensioni - dimensions [mm]					peso weight [kg/m]
		A	B	C	D	E	
	<b>000.523.7</b>	$\varnothing 32^{+0.16}$	32.5	45	14.5	20.5	2.368
	<b>000.524.7</b>	$\varnothing 40^{+0.16}$	38	53	22	-	2.984
	<b>000.525.7</b>	$\varnothing 50^{+0.19}$	46.5	63	24	-	3.823
	<b>000.526.7</b>	$\varnothing 63^{+0.19}$	56.5	76.5	29	-	5.686
	<b>000.527.7</b>	$\varnothing 80^{+0.22}$	72	95	40	18	7.544
	<b>000.528.7</b>	$\varnothing 100^{+0.45}$	89	115	40	28	10.919

composizione chimica chemical composition	Cu	Fe	Mn	Mg	Si	Zn	Cr	Ti	Al resto
	≤ 0.10	0.10 ÷ 0.30	≤ 0.10	0.35 ÷ 0.60	0.30 ÷ 0.60	≤ 0.15	≤ 0.05	≤ 0.10	

## Fori di fissaggio

dal  $\varnothing 32$  al  $\varnothing 100$  : predisposti per la filettatura metrica mediante rullatura

## Fixing holes

from  $\varnothing 32$  to  $\varnothing 100$  : prepared for metric thread through rolling

# fissaggi per cilindri compatti ISO

fixing elements for ISO compact cylinders



Per altre informazioni vedi le pagine 301-305 (fissaggi per cilindri ISO 6431 VDMA)

For more information see pages 301-305 (fixing elements for cylinders ISO 6431 VDMA)

<p><b>CERNIERA MASCHIO SNODO SFERICO</b></p>	<p><b>CMSS...</b></p>
<p><b>CERNIERA MASCHIO</b></p>	<p><b>CMIS...</b> <b>CMKS...</b></p>
<p><b>CERNIERA FEMMINA CON PERNO</b></p>	<p><b>CFIS...</b> <b>CFKS...</b></p>

$\varnothing$	A1	B1	C	D1
32	75	22	10	26
40	78	25	12	28
50	85	27	12	32
63	93	32	16	40
80	102	36	16	50
100	118	41	20	60

# fissaggi per cilindri compatti ISO

fixing elements for ISO compact cylinders



Per altre informazioni vedi le pagine 301-305 (fissaggi per cilindri ISO 6431 VDMA)

For more information see pages 301-305 (fixing elements for cylinders ISO 6431 VDMA)

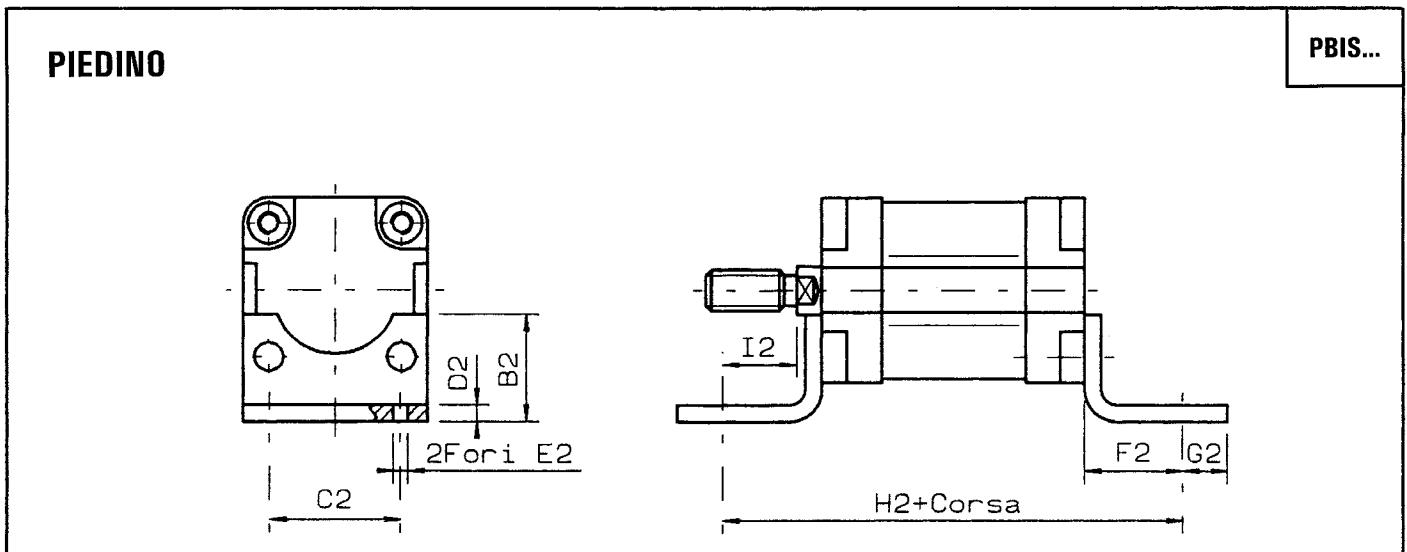
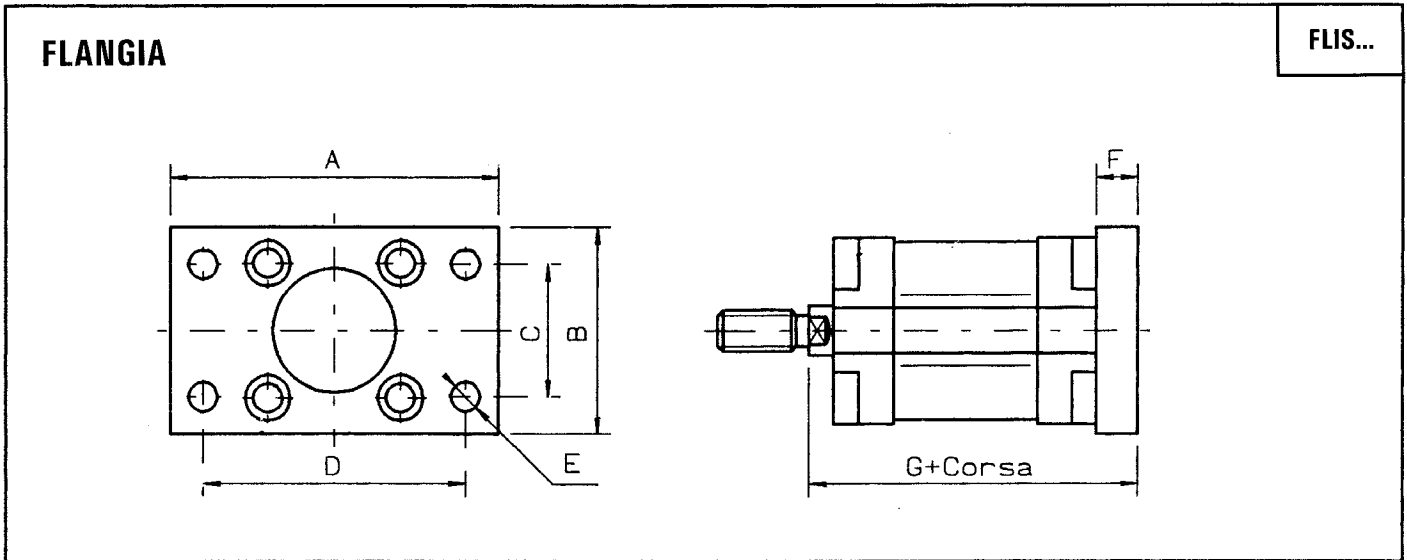

G	F	E	D	C	B	A	∅	B2	C2	D2	E2	F2	G2	H2	I2
63	10	7	64	32	45	80	32	30	32.5	4	7	24	11	94	17
63	10	9	72	36	52	90	40	30	38	4	9	28	8	102	21
70	12	9	90	45	65	110	50	36	46.5	5	9	32	15	114	24
73	12	9	100	50	75	120	63	35	56.5	5	9	32	13	117	24
82	16	12	126	63	95	150	80	47	72	6	12	41	14	138	31
93	16	14	150	75	115	170	100	53	89	6	14	41	16	149	31

## CERNIERA FEMMINA CON PERNO

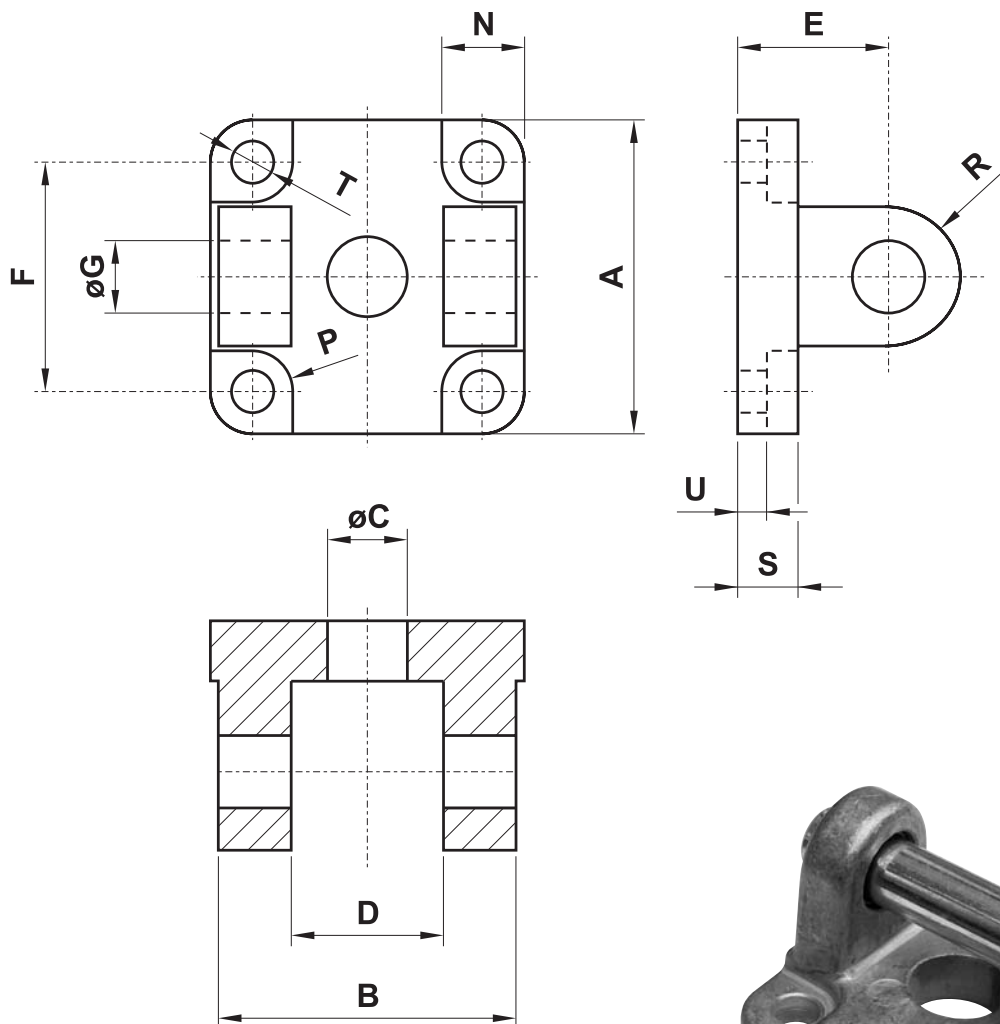

sigla part number	sigla part number	per alesaggio for bore	A	B	C	D	E	F	G	N	P	R	S	T	U
standard	con boccia di bronzo														
<b>CFUN032</b>	<b>CFKN032</b>	32	48	45	14	26	22	32	10	13.5	5.5	10	9	6.6	5.5
<b>CFUN040</b>	<b>CFKN040</b>	40	58	52	14	28	25	42	12	13.5	5.5	12.5	9	6.6	5.5
<b>CFUN050</b>	<b>CFKN050</b>	50	66	60	18	32	27	50	12	15.5	7.5	12.5	11	9	6.5
<b>CFUN063</b>	<b>CFKN063</b>	63	83	70	18	40	32	62	16	18	7.5	15	11	11	6.5
<b>CFUN080</b>	<b>CFKN080</b>	80	102	90	23	50	36	82	16	19	9	15	13	11	10
<b>CFUN100</b>	<b>CFKN100</b>	100	123	110	28	60	41	103	20	19	9	20	15	11	10

## FLANGIA

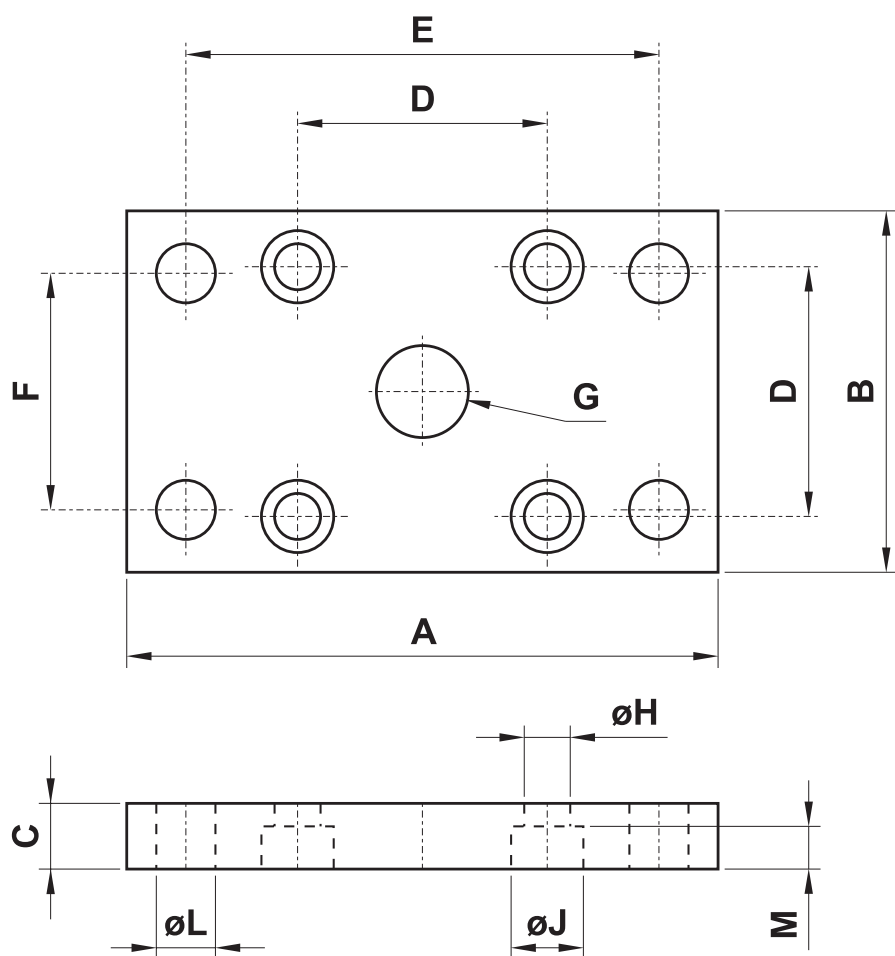
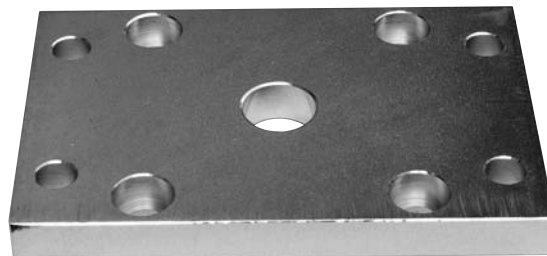

sigla part number	per alesaggio for bore	A	B	C	D	E	F	G	H	J	L	M
<b>FLUN032</b>	32	80	50	10	32	65	32	$\varnothing 14$	6.6	11	7	6.4
<b>FLUN040</b>	40	102	60	10	42	82	36	$\varnothing 14$	6.6	11	9	6.4
<b>FLUN050</b>	50	110	68	12	50	90	45	$\varnothing 18$	9	15	9	8.6
<b>FLUN063</b>	63	130	87	15	62	110	50	$\varnothing 18$	11	15	9	8.6
<b>FLUN080</b>	80	160	107	15	82	135	63	$\varnothing 23$	11	18	12	10.6
<b>FLUN100</b>	100	190	128	15	103	163	75	$\varnothing 28$	11	18	14	10.6

## PIEDINO

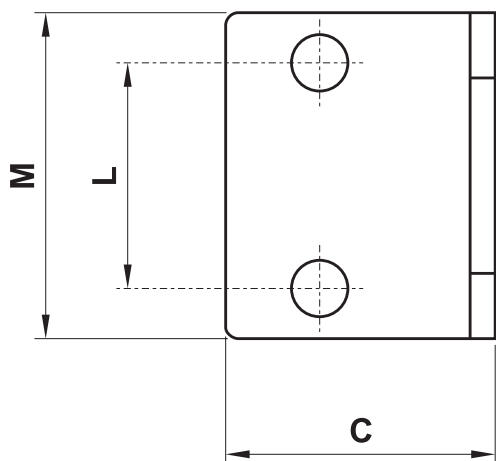
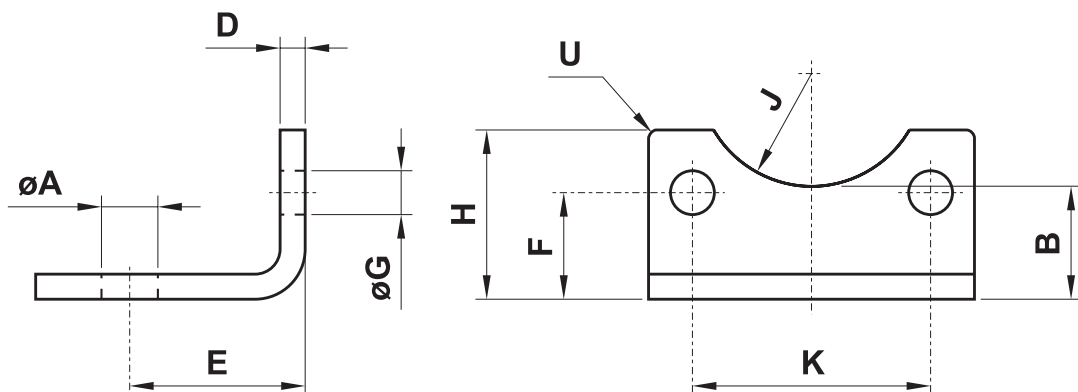

sigla* part number*	per alesaggio for bore	A	B	C	D	E	F	G	H	J	K	L	M	U
<b>PBUN032</b>	32	6.6	20	26	5	18	16	6.6	24	12	32	32	50	2
<b>PBUN040</b>	40	9	-	28	5	20	21.5	6.6	29.5	-	42	42	60	5
<b>PBUN050</b>	50	9	-	32	6	24	22	9	30	-	50	50	68	5
<b>PBUN063</b>	63	11	-	39	6	27	28.5	11	39	-	62	62	84	5
<b>PBUN080</b>	80	11	-	42	8	30	24.5	11	36.5	-	82	82	102	5
<b>PBUN100</b>	100	13.5	-	45	8	33	26.5	11	38.5	-	103	103	123	5

\* La sigla si riferisce a un solo piedino e non alla coppia

\* The part number is referred to only one element and not to the couple

# cilindri corsa breve

short stroke cylinders



- **Dimensioni di ingombro ridotte**  
*Reduced external dimensions*
- **Grande affidabilità e lunga durata**  
*High reliability and long life time*
- **Versione magnetica standard**  
*Standard magnetic version*
- **Esecuzioni e corse speciali a richiesta**  
*Special versions and strokes on request*

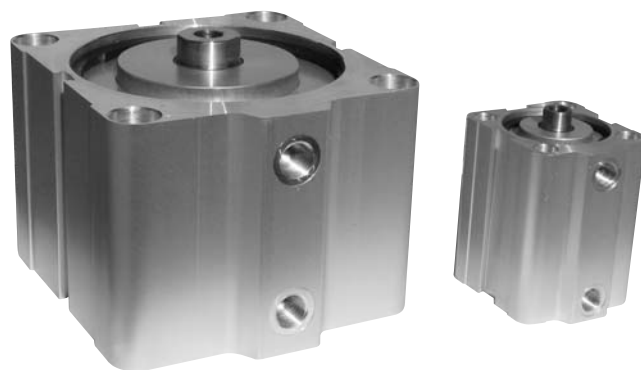

## Materiali

Camicia: alluminio

Stelo: C45 cromato o INOX AISI 304

Testate: alluminio con boccola guida stelo

Pistone: alluminio

Guarnizioni: NBR o VITON

Guarnizione stelo: poliuretano o VITON

Magnete: neodimio fino all'alesaggio 25  
plastroferrite dall'alesaggio 32 al 100

## Materials

Barrel: aluminium

Piston-rod: C45 (chromium plated) or stainless steel

End-cups: aluminium with rod guide

Piston: aluminium

Sealings: NBR or VITON

Piston-rod sealing: polyurethane or VITON

Magnet: neodymium from bore 16 to 25  
magnetic iron compound from bore 32 to 100

Pressione di esercizio <i>Working pressure</i>	max 10 bar max 1 MPa
Temperatura di esercizio <i>Temperature range</i>	NBR: max +60°C VITON: max +110°C
Alesaggi <i>Bores</i>	16; 20; 25; 32; 40; 50; 63; 80; 100 mm
Corse <i>Strokes</i>	5 ... 100 mm
Fluido <i>Fluid</i>	Aria filtrata 50µ con o senza lubrificazione 50µ filtered, lubricated or non lubricated air



## chiave di codifica

key to codes

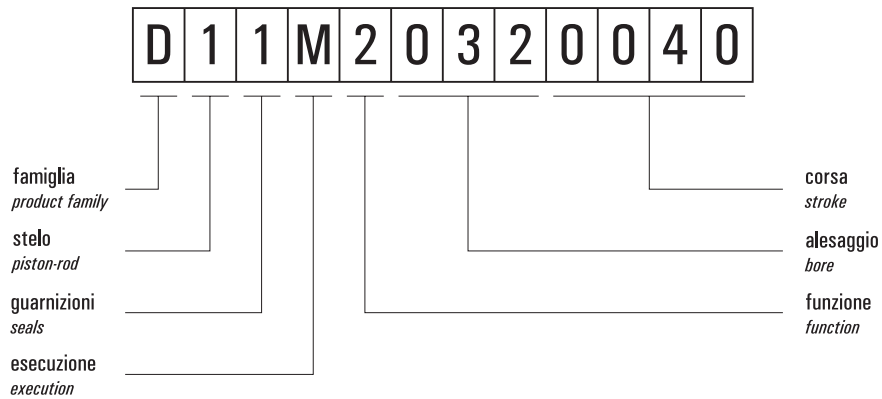

### Famiglia *[product family]*

**D** cilindri corsa breve *[short stroke cylinders]*

### Stelo *[piston-rod]*

**1** C45 cromato *[C45 chromium plated]*

**2** INOX *[stainless steel]*

### Guarnizioni *[seals]*

**1** NBR

**2** tutte le guarnizioni in VITON  
*[all seals in VITON]*

**3** guarnizioni dello stelo in VITON *[rod seals in VITON]*

### Esecuzione *[execution]*

**M** magnetico *[magnetic]*

### Funzione *[function]*

**1** semplice effetto non ammortizzato molla anteriore  
*[single acting front spring without pneumatic cushioning]*

**2** doppio effetto non ammortizzato  
*[double acting without pneumatic cushioning]*

**3** semplice effetto non ammortizzato molla posteriore  
*[single acting back spring without pneumatic cushioning]*

**4** doppio effetto non ammortizzato stelo passante  
*[double acting without pneumatic cushioning, with passing-through rod]*

# cilindri corsa breve

short stroke cylinders



disegno valido dall'alesaggio 32 all'alesaggio 100  
the drawing is valid from bore 32 to bore 100

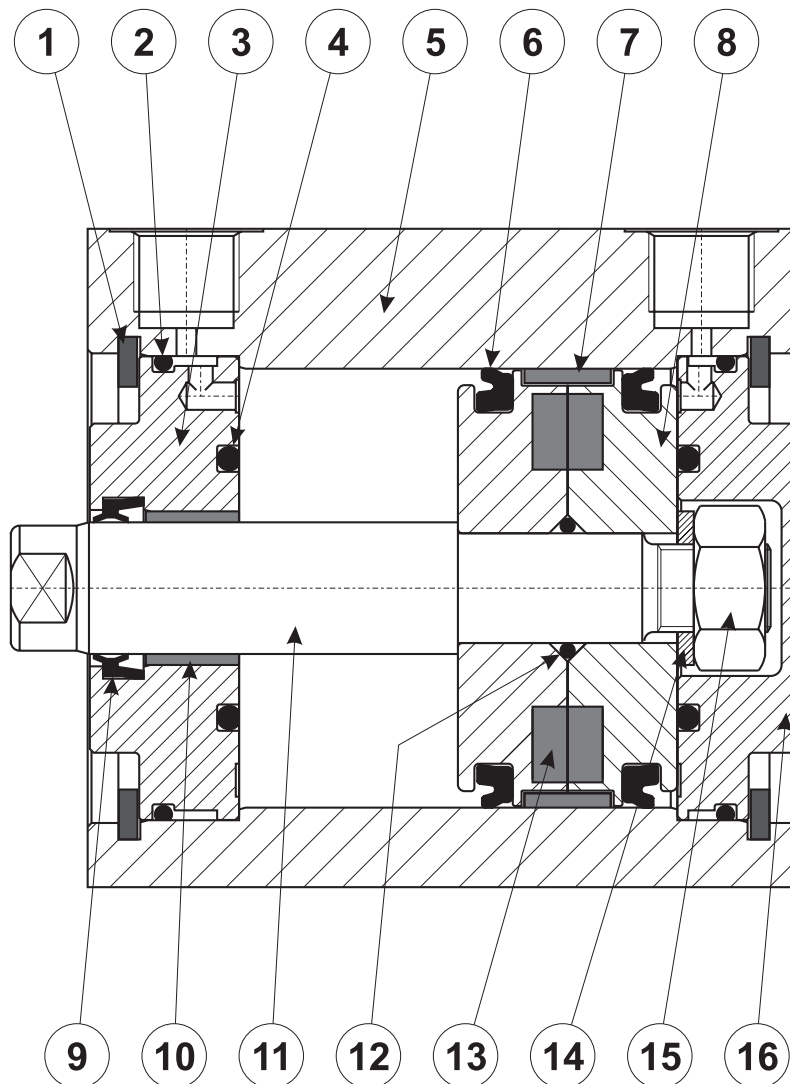

1. Anello SEEGER per fissaggio testata
2. O-Ring per tenuta testata: NBR o VITON
3. Testata anteriore: alluminio
4. O-Ring paracolpi: NBR o VITON
5. Camicia: alluminio profilato, calibrato e anodizzato
6. Guarnizione a labbro per pistone: NBR o VITON
7. Anello guida per pistone: bronzo PTFE
8. Pistone: alluminio
9. Guarnizione stelo: POLIURETANO o VITON
10. Boccola guida: materiale autolubrificante
11. Stelo: acciaio C45 cromato o INOX AISI 304
12. O-Ring per tenuta pistone: NBR o VITON
13. Magnete: plastoferrite
14. Rondella piana
15. Dado per bloccaggio stelo
16. Testata posteriore: alluminio

# cilindri corsa breve

short stroke cylinders



## versioni disponibili

available versions

<b>semplice effetto molla anteriore</b> <i>single acting front spring</i> <b>magnetico</b> <i>magnetic</i> <b>non ammortizzato</b> <i>without pneumatic cushioning</i>	alesaggio		16	20	25	32	40	50	63	80	100	<b>OPZIONI</b> <i>options</i>  Lo standard è evidenziato in grigio <i>The standard is marked with grey background</i>  <b>materiale stelo (piston-rod material)</b>  <table border="1"> <tr> <td>C45 cromato <i>C45 chromium plated</i></td> <td>INOX <i>stainless steel</i></td> </tr> </table> <b>materiale guarnizioni (seals material)</b>  <table border="1"> <tr> <td>NBR</td> <td>tutte in VITON <i>all seals in VITON</i></td> <td>guarnizioni stelo in VITON <i>rod seals in VITON</i></td> </tr> </table>	C45 cromato <i>C45 chromium plated</i>	INOX <i>stainless steel</i>	NBR	tutte in VITON <i>all seals in VITON</i>	guarnizioni stelo in VITON <i>rod seals in VITON</i>
	C45 cromato <i>C45 chromium plated</i>	INOX <i>stainless steel</i>															
NBR	tutte in VITON <i>all seals in VITON</i>	guarnizioni stelo in VITON <i>rod seals in VITON</i>															
corsa	bore	stroke															
5						X	X	X	X	X	X						
10						X	X	X	X	X	X						
25						X	X	X	X	X	X						
30								X	X	X	X						
40																	
50																	
75																	
100																	
<b>semplice eff. molla posteriore</b> <i>single acting back spring</i> <b>magnetico</b> <i>magnetic</i> <b>non ammortizzato</b> <i>without pneumatic cushioning</i>	alesaggio		16	20	25	32	40	50	63	80	100	<b>OPZIONI</b> <i>options</i>  Lo standard è evidenziato in grigio <i>The standard is marked with grey background</i>  <b>materiale stelo (piston-rod material)</b>  <table border="1"> <tr> <td>C45 cromato <i>C45 chromium plated</i></td> <td>INOX <i>stainless steel</i></td> </tr> </table> <b>materiale guarnizioni (seals material)</b>  <table border="1"> <tr> <td>NBR</td> <td>tutte in VITON <i>all seals in VITON</i></td> <td>guarnizioni stelo in VITON <i>rod seals in VITON</i></td> </tr> </table>	C45 cromato <i>C45 chromium plated</i>	INOX <i>stainless steel</i>	NBR	tutte in VITON <i>all seals in VITON</i>	guarnizioni stelo in VITON <i>rod seals in VITON</i>
	C45 cromato <i>C45 chromium plated</i>	INOX <i>stainless steel</i>															
	NBR	tutte in VITON <i>all seals in VITON</i>	guarnizioni stelo in VITON <i>rod seals in VITON</i>														
	corsa	bore	stroke														
	5						X	X	X	X	X		X				
	10						X	X	X	X	X		X				
	25						X	X	X	X	X		X				
	30								X	X	X		X				
	40																
	50																
75																	
100																	

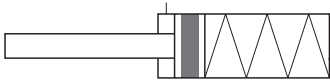
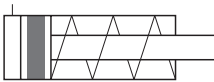

# cilindri corsa breve

short stroke cylinders



## versioni disponibili

available versions

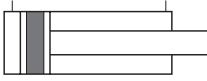
<b>doppio effetto</b> <i>double acting</i> <b>magnetico</b> <i>magnetic</i> <b>non ammortizzato</b> <i>without pneumatic cushioning</i>	alesaggio											<b>OPZIONI</b> <i>options</i>  Lo standard è evidenziato in grigio <i>The standard is marked with grey background</i>											
	corsa	bore	16	20	25	32	40	50	63	80	100		<b>materiale stelo (piston-rod material)</b>										
	5		X	X	X	X	X	X	X	X	X	X	X	<b>C45 cromato</b> <i>C45 chromium plated</i>		<b>INOX</b> <i>stainless steel</i>							
	10		X	X	X	X	X	X	X	X	X	X	X	<b>materiale guarnizioni (seals material)</b>		<b>NBR</b>		<b>tutte in VITON</b> <i>all seals in VITON</i>		<b>guarnizioni stelo in VITON</b> <i>rod seals in VITON</i>			
	25		X	X	X	X	X	X	X	X	X	X	X	<b>C45 cromato</b> <i>C45 chromium plated</i>		<b>INOX</b> <i>stainless steel</i>		<b>NBR</b>		<b>tutte in VITON</b> <i>all seals in VITON</i>		<b>guarnizioni stelo in VITON</b> <i>rod seals in VITON</i>	
	30		X	X	X	X	X	X	X	X	X	X	X	<b>C45 cromato</b> <i>C45 chromium plated</i>		<b>INOX</b> <i>stainless steel</i>		<b>NBR</b>		<b>tutte in VITON</b> <i>all seals in VITON</i>		<b>guarnizioni stelo in VITON</b> <i>rod seals in VITON</i>	
	40		X	X	X	X	X	X	X	X	X	X	X	<b>C45 cromato</b> <i>C45 chromium plated</i>		<b>INOX</b> <i>stainless steel</i>		<b>NBR</b>		<b>tutte in VITON</b> <i>all seals in VITON</i>		<b>guarnizioni stelo in VITON</b> <i>rod seals in VITON</i>	
	50			X	X	X	X	X	X	X	X	X	X	<b>C45 cromato</b> <i>C45 chromium plated</i>		<b>INOX</b> <i>stainless steel</i>		<b>NBR</b>		<b>tutte in VITON</b> <i>all seals in VITON</i>		<b>guarnizioni stelo in VITON</b> <i>rod seals in VITON</i>	
	75										X	X	X	<b>C45 cromato</b> <i>C45 chromium plated</i>		<b>INOX</b> <i>stainless steel</i>		<b>NBR</b>		<b>tutte in VITON</b> <i>all seals in VITON</i>		<b>guarnizioni stelo in VITON</b> <i>rod seals in VITON</i>	
	100											X	X	<b>C45 cromato</b> <i>C45 chromium plated</i>		<b>INOX</b> <i>stainless steel</i>		<b>NBR</b>		<b>tutte in VITON</b> <i>all seals in VITON</i>		<b>guarnizioni stelo in VITON</b> <i>rod seals in VITON</i>	
<b>doppio effetto</b> <i>double acting</i> <b>magnetico</b> <i>magnetic</i> <b>non ammortizzato</b> <i>without pneumatic cushioning</i> <b>stelo passante</b> <i>passing-through rod</i>	alesaggio											<b>OPZIONI</b> <i>options</i>  Lo standard è evidenziato in grigio <i>The standard is marked with grey background</i>											
	corsa	bore	16	20	25	32	40	50	63	80	100		<b>materiale stelo (piston-rod material)</b>										
	5		X	X	X	X	X	X	X	X	X	X	X	<b>C45 cromato</b> <i>C45 chromium plated</i>		<b>INOX</b> <i>stainless steel</i>		<b>NBR</b>		<b>tutte in VITON</b> <i>all seals in VITON</i>		<b>guarnizioni stelo in VITON</b> <i>rod seals in VITON</i>	
	10		X	X	X	X	X	X	X	X	X	X	X	<b>C45 cromato</b> <i>C45 chromium plated</i>		<b>INOX</b> <i>stainless steel</i>		<b>NBR</b>		<b>tutte in VITON</b> <i>all seals in VITON</i>		<b>guarnizioni stelo in VITON</b> <i>rod seals in VITON</i>	
	25		X	X	X	X	X	X	X	X	X	X	X	<b>C45 cromato</b> <i>C45 chromium plated</i>		<b>INOX</b> <i>stainless steel</i>		<b>NBR</b>		<b>tutte in VITON</b> <i>all seals in VITON</i>		<b>guarnizioni stelo in VITON</b> <i>rod seals in VITON</i>	
	30		X	X	X	X	X	X	X	X	X	X	X	<b>C45 cromato</b> <i>C45 chromium plated</i>		<b>INOX</b> <i>stainless steel</i>		<b>NBR</b>		<b>tutte in VITON</b> <i>all seals in VITON</i>		<b>guarnizioni stelo in VITON</b> <i>rod seals in VITON</i>	
	40		X	X	X	X	X	X	X	X	X	X	X	<b>C45 cromato</b> <i>C45 chromium plated</i>		<b>INOX</b> <i>stainless steel</i>		<b>NBR</b>		<b>tutte in VITON</b> <i>all seals in VITON</i>		<b>guarnizioni stelo in VITON</b> <i>rod seals in VITON</i>	
	50			X	X	X	X	X	X	X	X	X	X	<b>C45 cromato</b> <i>C45 chromium plated</i>		<b>INOX</b> <i>stainless steel</i>		<b>NBR</b>		<b>tutte in VITON</b> <i>all seals in VITON</i>		<b>guarnizioni stelo in VITON</b> <i>rod seals in VITON</i>	
75										X	X	X	<b>C45 cromato</b> <i>C45 chromium plated</i>		<b>INOX</b> <i>stainless steel</i>		<b>NBR</b>		<b>tutte in VITON</b> <i>all seals in VITON</i>		<b>guarnizioni stelo in VITON</b> <i>rod seals in VITON</i>		
100											X	X	<b>C45 cromato</b> <i>C45 chromium plated</i>		<b>INOX</b> <i>stainless steel</i>		<b>NBR</b>		<b>tutte in VITON</b> <i>all seals in VITON</i>		<b>guarnizioni stelo in VITON</b> <i>rod seals in VITON</i>		

# cilindri corsa breve

short stroke cylinders



## VERSIONE NORMALE - alesaggio 16, 20, 25

Normal version - bore 16, 20, 25

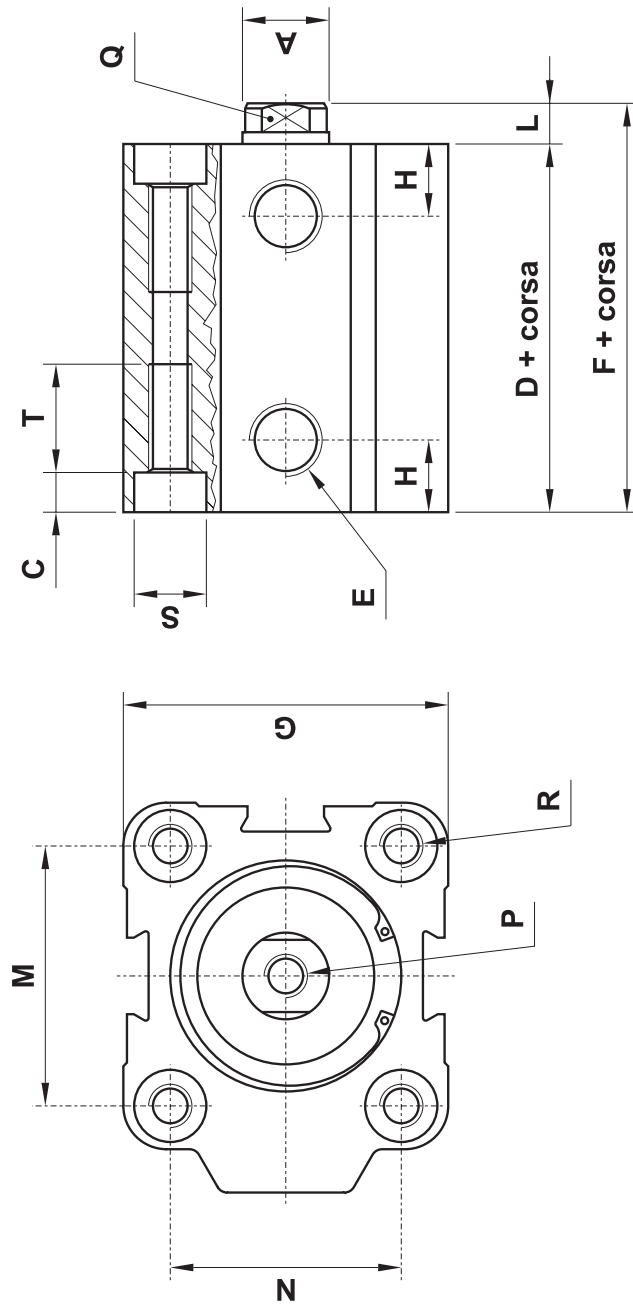

Ø	A	C	D	E	F	G	H	L	M	N	P	Q	R	S	T
16	Ø8	3.5	36	M5	41.5	28	8	5.5	20	20	M5	CH 7	M4	Ø6	10
20	Ø10	4.5	36	M5	41.5	32	8.5	5.5	22	22	M5	CH 8	M5	Ø7	12
25	Ø10	4.5	38	G1/8"	43.5	38	9	5.5	28	26	M5	CH 8	M5	Ø7	12

# cilindri corsa breve

short stroke cylinders



## VERSIONE NORMALE - alesaggio 32, 40, 50, 63, 80, 100

Normal version - bore 32, 40, 50, 63, 80, 100

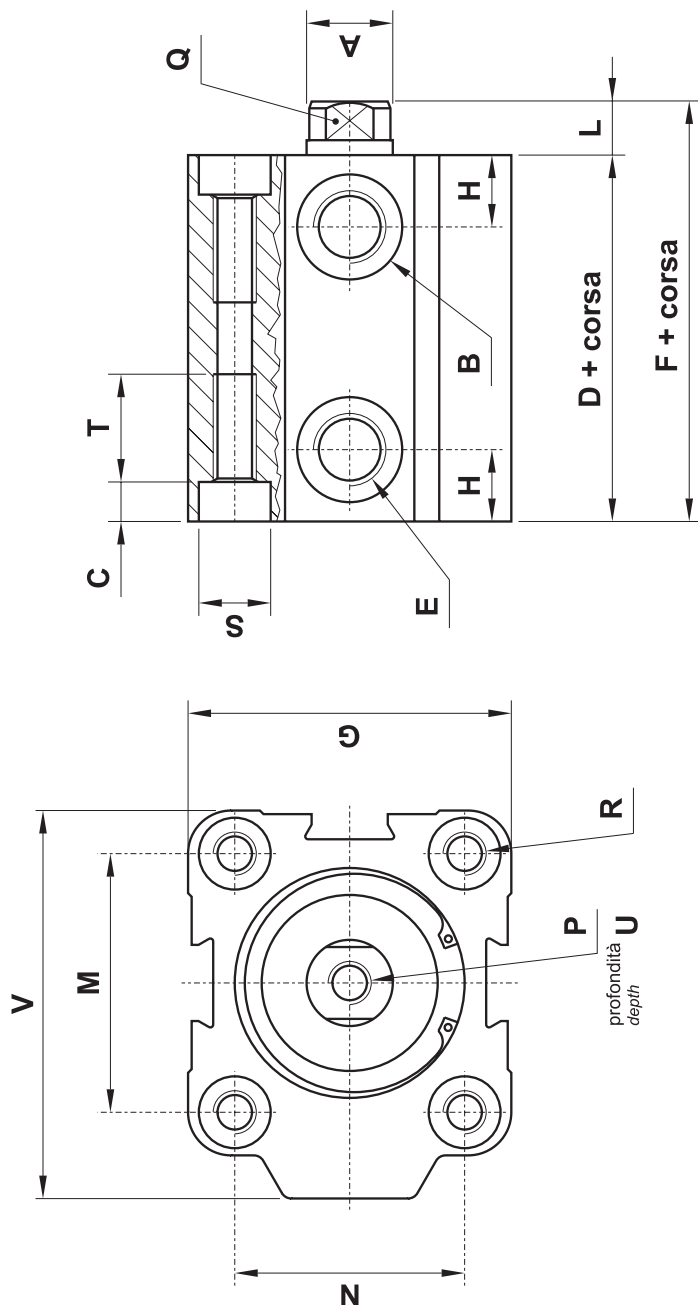

Ø	A	B	C	D	E	F	G	H	L	M	N	P	Q	R	S	T	U	V
32	Ø12	Ø14	5.5	46.2	G1/8"	53.2	45	9	7	36	32	M8	CH 10	M6	Ø9	15	13.5	54
40	Ø12	Ø14	5.5	46.2	G1/8"	53.2	54.5	10	7	40	40	M8	CH 10	M6	Ø9	15	13.5	60
50	Ø16	Ø14	6.5	50	G1/8"	58	65	11.5	8	50	50	M10	CH 13	M8	Ø11	20	16	72.5
63	Ø16	Ø14	8.5	53	G1/8"	61	80	11.5	8	62	62	M10	CH 13	M10	Ø14	20	16	88
80	Ø20	Ø19	8.5	56.4	G1/4"	66.2	100	13.8	9.8	82	82	M10	CH 17	M10	Ø14	22.5	20	110
100	Ø25	Ø19	11	67	G1/4"	76.8	124	17	9.8	103	103	M12	CH 22	M12	Ø17	24	24	134

## VERSIONE CON STELO PASSANTE - alesaggio 16, 20, 25

Version with passing-through rod - bore 16, 20, 25

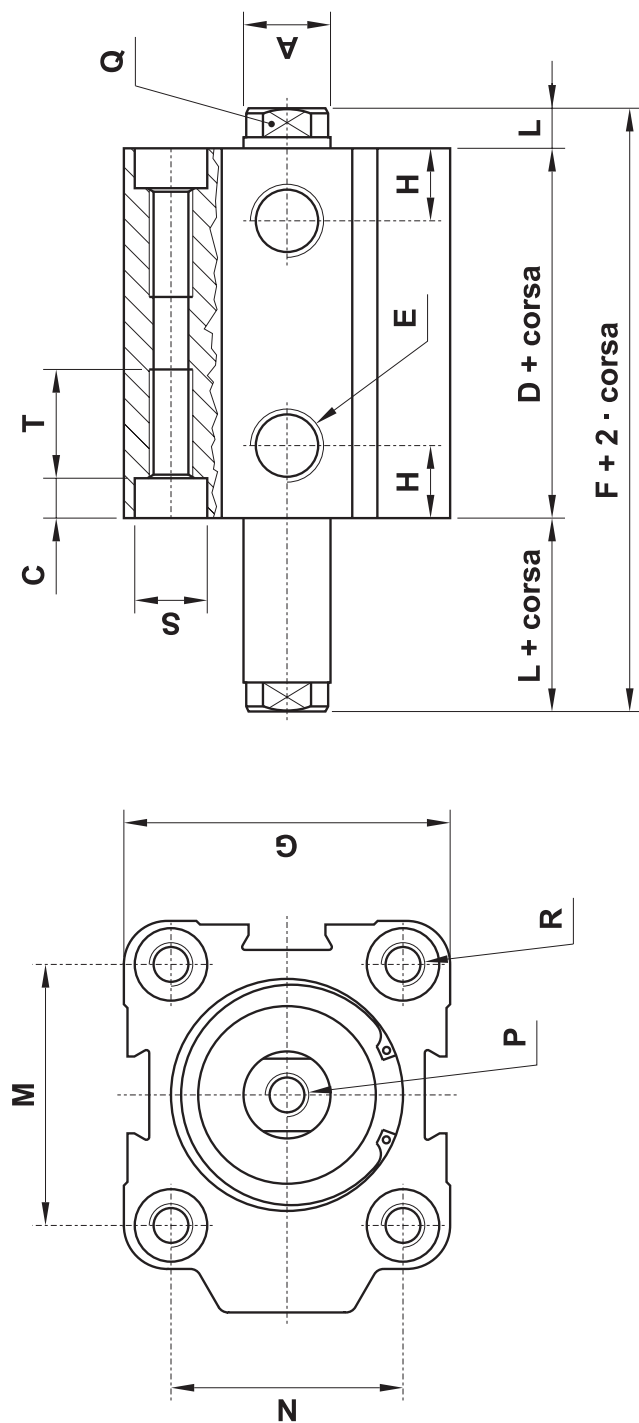

Ø	A	C	D	E	F	G	H	L	M	N	P	Q	R	S	T
16	ø8	3.5	36	M5	47	28	8	5.5	20	20	M5	CH 7	M4	ø6	10
20	ø10	4.5	36	M5	47	32	8.5	5.5	22	22	M5	CH 8	M5	ø7	12
25	ø10	4.5	38	G1/8"	49	38	9	5.5	28	26	M5	CH 8	M5	ø7	12

# cilindri corsa breve

short stroke cylinders



## VERSIONE CON STELO PASSANTE - alesaggio 32, 40, 50, 63, 80, 100

Version with passing-through rod - bore 32, 40, 50, 63, 80, 100

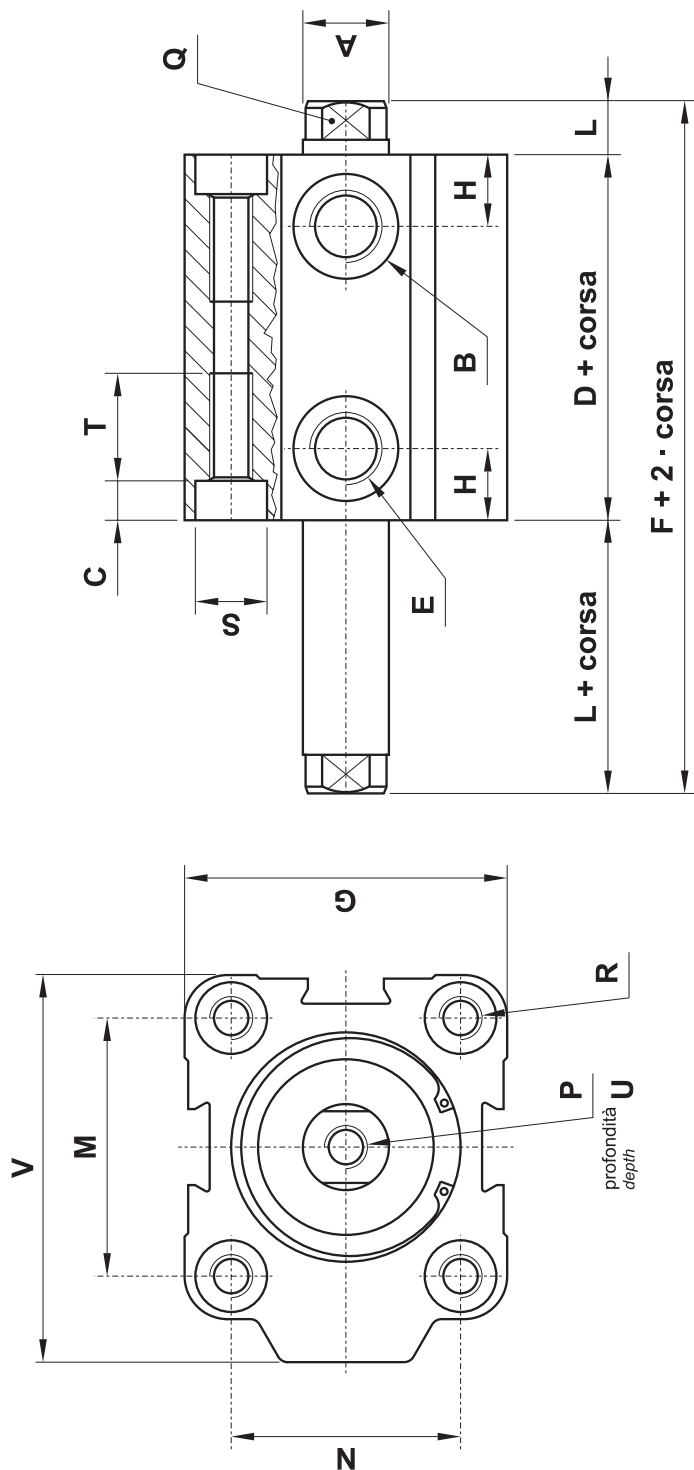

Ø	A	B	C	D	E	F	G	H	I	J	K	L	M	N	O	P	Q	R	S	T	U	V
32	Ø12	Ø14	5.5	46.2	G1/8"	60.2	45	9	7	36	32	7	36	32	CH 10	M8	CH 10	M6	Ø9	15	13.5	54
40	Ø12	Ø14	5.5	46.2	G1/8"	60.2	54.5	10	7	40	40	7	40	40	CH 10	M8	CH 10	M6	Ø9	15	13.5	60
50	Ø16	Ø14	6.5	50	G1/8"	66	65	11.5	8	50	50	8	50	50	CH 13	M10	CH 13	M8	Ø11	20	16	72.5
63	Ø16	Ø14	8.5	53	G1/8"	69	80	11.5	8	62	62	8	62	62	CH 13	M10	CH 13	M10	Ø14	20	16	88
80	Ø20	Ø19	8.5	56.4	G1/4"	76	100	13.8	9.8	82	82	9.8	82	82	CH 17	M10	CH 17	M10	Ø14	22.5	20	110
100	Ø25	Ø19	11	67	G1/4"	86.6	124	17	9.8	103	103	9.8	103	103	CH 22	M12	CH 22	M12	Ø17	24	24	134





## kit guarnizioni di ricambio

seals kit

<b>MAGNETICO, guarnizioni standard</b>					
<b>normale</b>			<b>stelo passante [passing-through rod]</b>		
per alesaggio for bore	sigla part number	codice code	per alesaggio for bore	sigla part number	codice code
16	<b>GD016</b>	22.100.2	16	<b>GD016P</b>	22.110.2
20	<b>GD020</b>	22.101.2	20	<b>GD020P</b>	22.111.2
25	<b>GD025</b>	22.102.2	25	<b>GD025P</b>	22.112.2
32	<b>GD032</b>	22.103.2	32	<b>GD032P</b>	22.113.2
40	<b>GD040</b>	22.104.2	40	<b>GD040P</b>	22.114.2
50	<b>GD050</b>	22.105.2	50	<b>GD050P</b>	22.115.2
63	<b>GD063</b>	22.106.2	63	<b>GD063P</b>	22.116.2
80	<b>GD080</b>	22.107.2	80	<b>GD080P</b>	22.117.2
100	<b>GD100</b>	22.108.2	100	<b>GD100P</b>	22.118.2
<b>MAGNETICO, guarnizioni VITON</b>					
<b>normale</b>			<b>stelo passante [passing-through rod]</b>		
per alesaggio for bore	sigla part number	codice code	per alesaggio for bore	sigla part number	codice code
16	<b>GD016V</b>	22.120.2	16	<b>GD016PV</b>	22.130.2
20	<b>GD020V</b>	22.121.2	20	<b>GD020PV</b>	22.131.2
25	<b>GD025V</b>	22.122.2	25	<b>GD025PV</b>	22.132.2
32	<b>GD032V</b>	22.123.2	32	<b>GD032PV</b>	22.133.2
40	<b>GD040V</b>	22.124.2	40	<b>GD040PV</b>	22.134.2
50	<b>GD050V</b>	22.125.2	50	<b>GD050PV</b>	22.135.2
63	<b>GD063V</b>	22.126.2	63	<b>GD063PV</b>	22.136.2
80	<b>GD080V</b>	22.127.2	80	<b>GD080PV</b>	22.137.2
100	<b>GD100V</b>	22.128.2	100	<b>GD100PV</b>	22.138.2

## dado per fissaggio in cava

fixing nut

Permette di fissare un cilindro a parete o di fissare sul cilindro le interfacce per valvole, di cui alle pagine 127 e 171. È utilizzabile anche per i cilindri ISO 6431 fino al  $\varnothing 125$  e per i cilindri compatti.

*It can be used to fix a cylinder on the side or to mount on the cylinder an interface for valves (see page 127 and 171). It can be used also for ISO 6431 cylinders (up to bore 125) and for compact cylinders.*

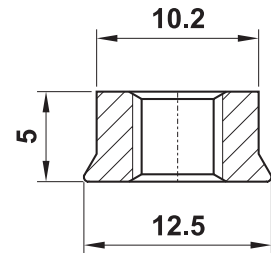

sigla part number	codice order code	A
<b>DCCB 16/32</b>	26.156.0T	M5
<b>DCCB 32/100</b>	26.157.0T	M6

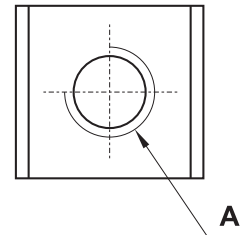

# cilindri ad asta gemellata

*twin rod cylinders*



- Grande affidabilità e lunga durata  
*High reliability and long life time*
- Versione magnetica standard  
*Standard magnetic version*
- Ammortizzo pneumatico standard su tutta la gamma  
*Pneumatic cushioning standard on the whole range*
- Esecuzioni e corse speciali a richiesta  
*Special versions and strokes on request*

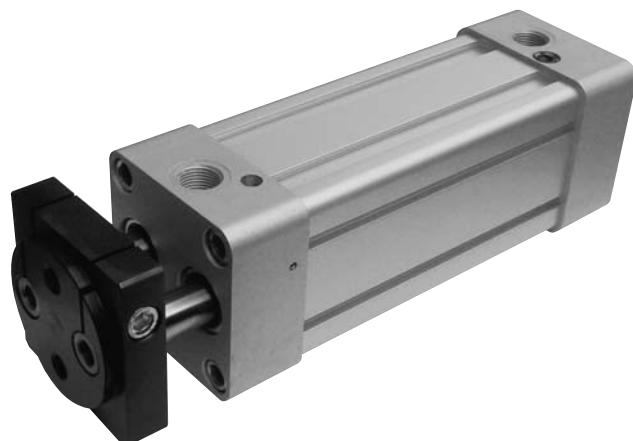

## Materiali

Camicia: alluminio

Steli: C45 cromato

Testate: alluminio

Pistone: alluminio

Guarnizioni: NBR

Flangia: acciaio brunito

Boccole guida stelo: bronzo sinterizzato

Guida pistone: PTFE a basso attrito

## Materials

Barrel: aluminium

Piston-rods: C45 (chromium plated)

End-cups: aluminium

Piston: aluminium

Sealings: NBR

Flange: burnished steel

Rod guides: sintered bronze

Piston guide: low friction PTFE

Pressione di esercizio <i>Working pressure</i>	max 10 bar max 1 MPa
Temperatura di esercizio <i>Temperature range</i>	max +60°C
Alesaggi <i>Bores</i>	32; 40; 50; 63; 80; 100 mm
Corse <i>Strokes</i>	25; 50; 80; 100; 125; 150; 160; 200; 250; 300; 320; 400; 500 mm
Fluido <i>Fluid</i>	Aria filtrata 50µ con o senza lubrificazione <i>50µ filtered, lubricated or non lubricated air</i>

## chiave di codifica

*key to codes*

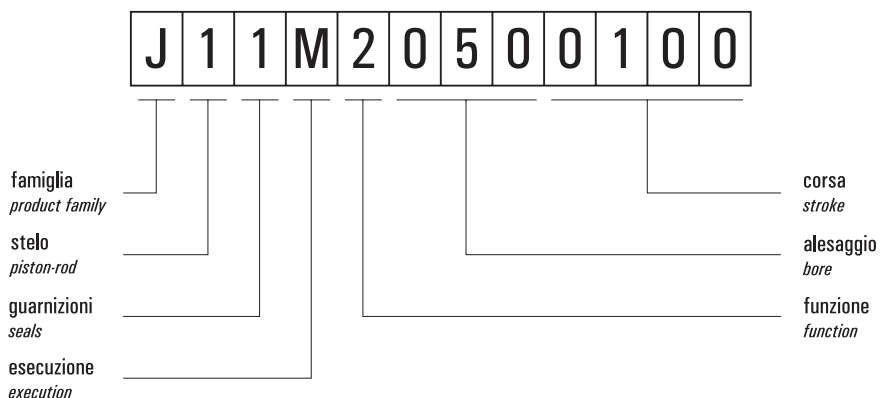

### Famiglia *[product family]*

**J** cilindri ad asta gemellata  
*[twin rod cylinders]*

### Steli *[piston-rods]*

**1** C45 cromato *[C45 chromium plated]*

### Guarnizioni *[seals]*

**1** NBR

### Esecuzione *[execution]*

**M** magnetico *[magnetic]*

### Funzione *[function]*

- 2** doppio effetto ammortizzato  
*[double acting with pneumatic cushioning]*
- 4** doppio effetto ammortizzato stelo passante ISO  
*[double acting with pneumatic cushioning, with ISO passing-through rod]*
- 9** doppio effetto ammortizzato asta gemellata passante  
*[double acting with pneumatic cushioning, with twin passing-through rod]*

# cilindri ad asta gemellata

twin rod cylinders



## J11M2

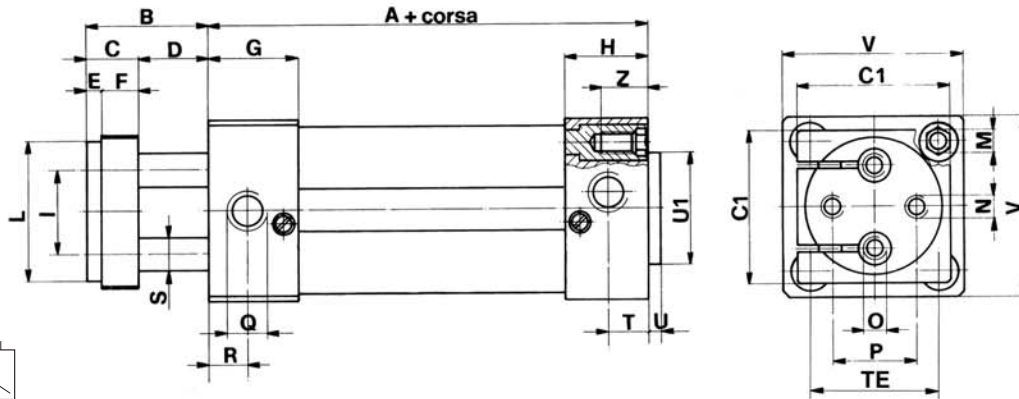

## J11M4

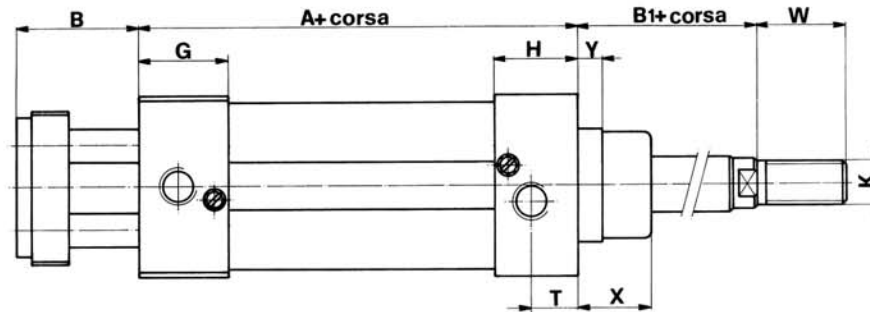

## J11M9

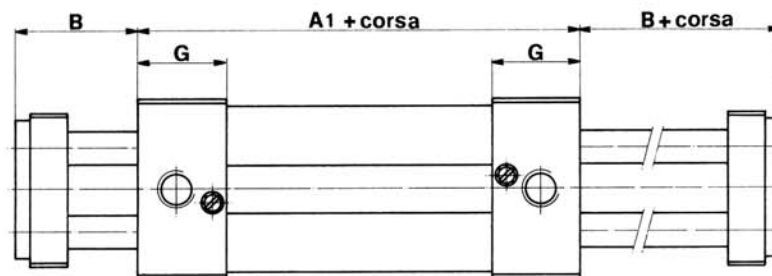

Ø	A	A1	B	B1	C	C1	D	E	F	G	H	I	L	M	N	O	P	Q
32	100	111	40	26	15	45	25	4	11	30	24,5	18	32	M6	M6	-	19	G1/8
40	101	104	40	30	15	50	25	4	11	26,5	27,5	22	40	M6	M8	-	22	G1/4
50	108,5	113	43	37	18	55	25	5	13	32	31	30	50	M8	M8	M8	30	G1/4
63	119	125	47	37	22	70	25	5	17	34	35,5	38	63	M8	M10	M10	38	G3/8
80	134	135	50	46	25	90	25	5	20	38	40	48	80	M10	M12	M12	50	G3/8
100	144	142	50	51	25	110	25	5	20	36	43	60	100	M10	M12	M12	70	G1/2
Ø	R	S	T	TE	U	U1	V	Z	W	Y	X	K						
32	13	10	14	32,5	4	30	45	18	22	6	20	M10X1,25						
40	11,5	10	17	38	4	35	52	18	24	6	22	M12X1,25						
50	14	12	18	46,5	4	40	65	23	32	8	26	M16X1,5						
63	14	16	17,5	56,5	4	45	75	23	32	8	26	M16X1,5						
80	15	22	20,5	72	4	45	95	30	40	10	40	M20X1,5						
100	15	22	18	89	4	55	115	30	40	10	40	M20X1,5						

# cilindri ad asta gemellata

twin rod cylinders



## FLANGIA

FLIS...

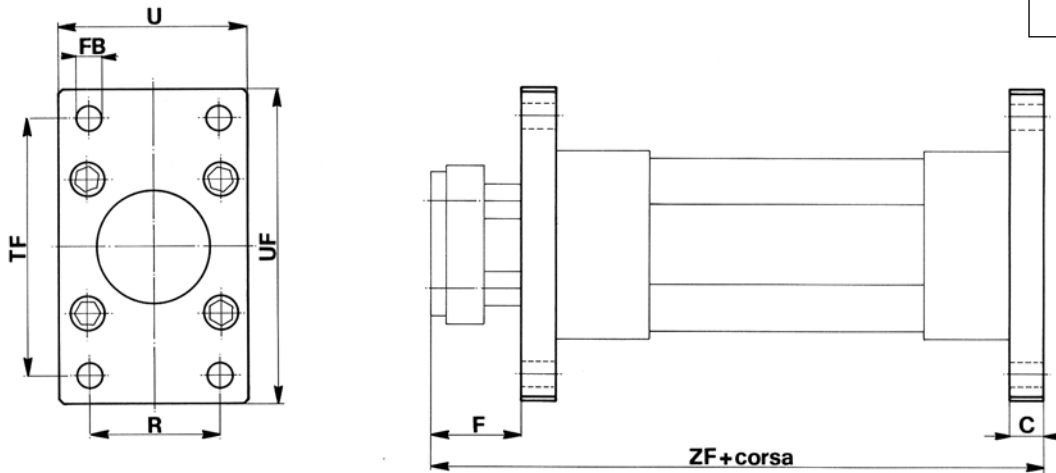

ø	DIM.	C	F	R	U	FB	TF	UF	ZF
32		10	30	32	45	7	64	80	150
40		10	30	36	52	9	72	90	151
50		12	31	45	65	9	90	110	163,5
63		12	35	50	75	9	100	120	178
80		16	34	63	95	12	126	150	200
100		16	34	75	115	14	150	170	210

La flangia ISO standard si può montare sulla testata posteriore di tutti gli alesaggi. Sulla testata anteriore si può montare solo sugli alesaggi 32 e 40. Per gli altri alesaggi contattare l'ufficio commerciale.

*The standard ISO flange can be mounted on the back end-cup for all bores. On the front end-cup it can be mounted only for bore 32 and 40. For other bores please contact our commercial office.*

## CERNIERA MASCHIO

CMIS...

CMKS...

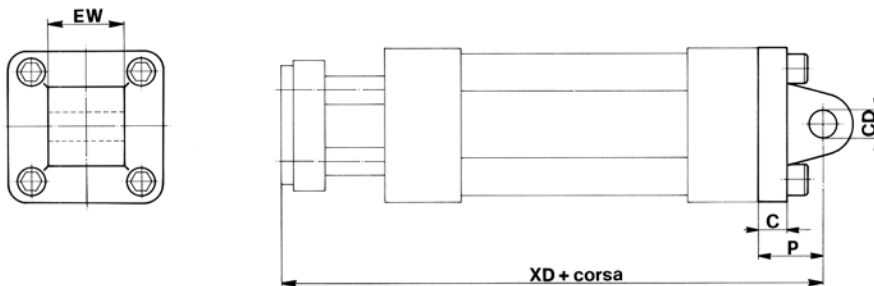

ø	DIM.	C	CD	P	EW	XD
32		9	10	22	26	162
40		9	12	25	28	166
50		11	12	27	32	178,5
63		11	16	32	40	198
80		14	16	36	50	220
100		14	20	41	60	235

# cilindri ad asta gemellata

*twin rod cylinders*



## PIEDINO

PBIS...

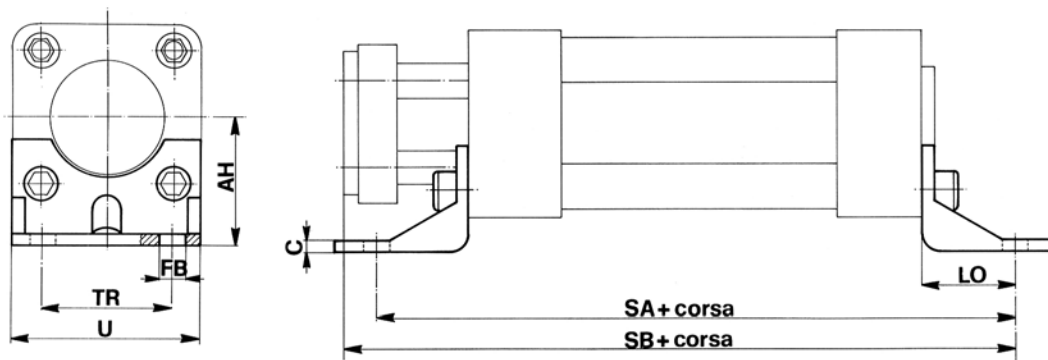

ø	DIM.	C	AH	FB	LO	SA	SB	TR	U
32		4	32	7	24	148	164	32	45
40		4	36	9	28	157	169	36	52
50		5	45	9	32	172,5	183,5	45	65
63		5	50	9	32	183	198	50	75
80		6	63	12	41	216	225	63	95
100		6	71	14	41	226	235	75	115

## CERNIERA FEMMINA CON PERNO

CFIS...

CFKS...

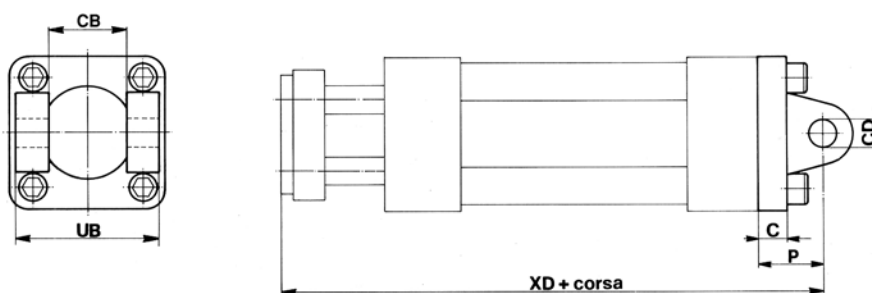

ø	DIM.	C	CD	P	CB	UB	XD
32		9	10	22	26	45	162
40		9	12	25	28	52	166
50		11	12	27	32	60	178,5
63		11	16	32	40	70	198
80		14	16	36	50	90	220
100		14	20	41	60	110	235

## momenti flettenti

*bending moments*

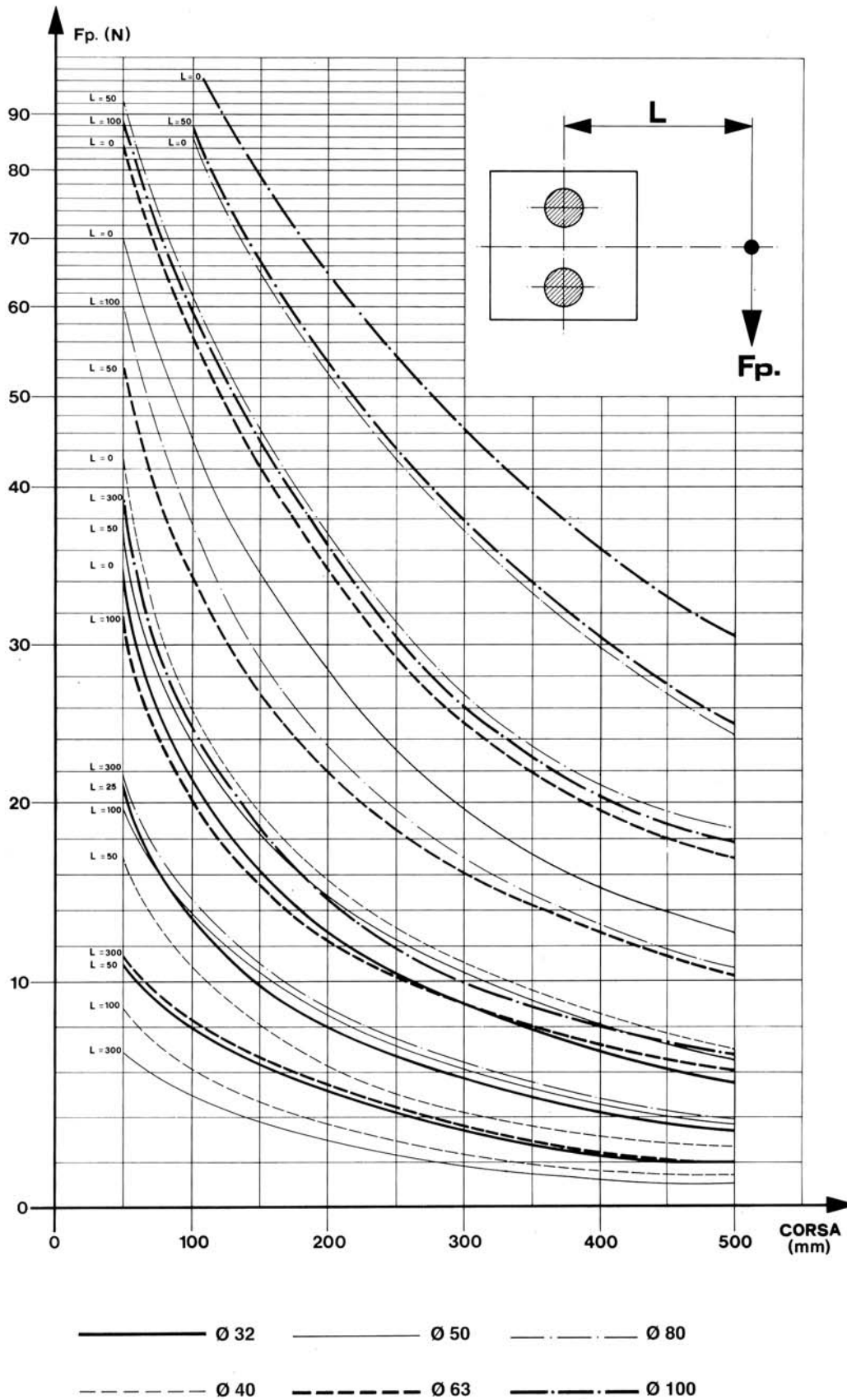



# cilindri ad asta gemellata

*twin rod cylinders*



## carichi a flessione

*flexion loads*

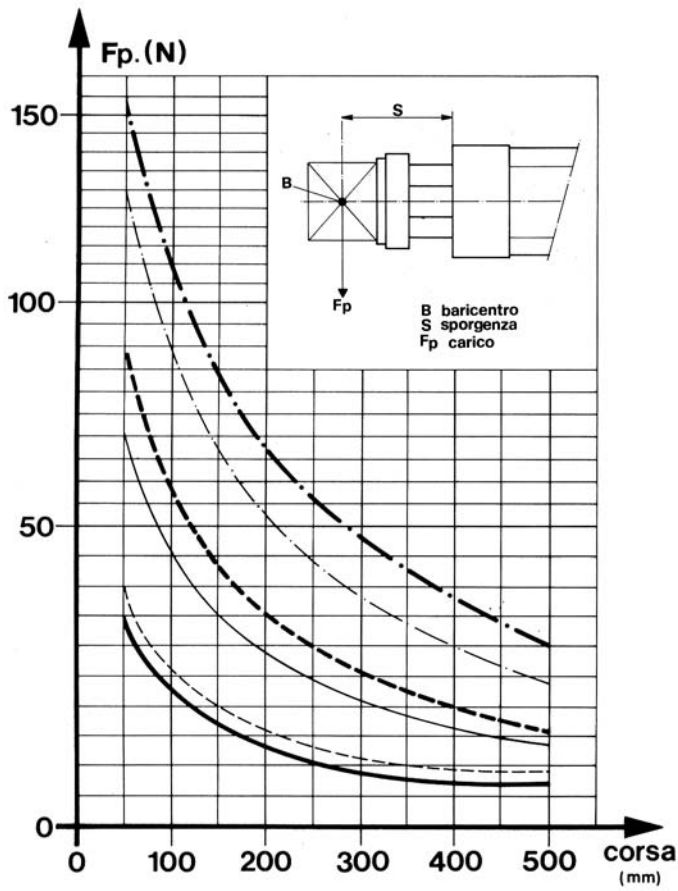

## momenti torcenti

*twisting moments*

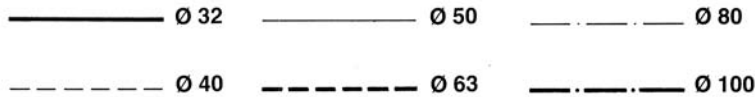
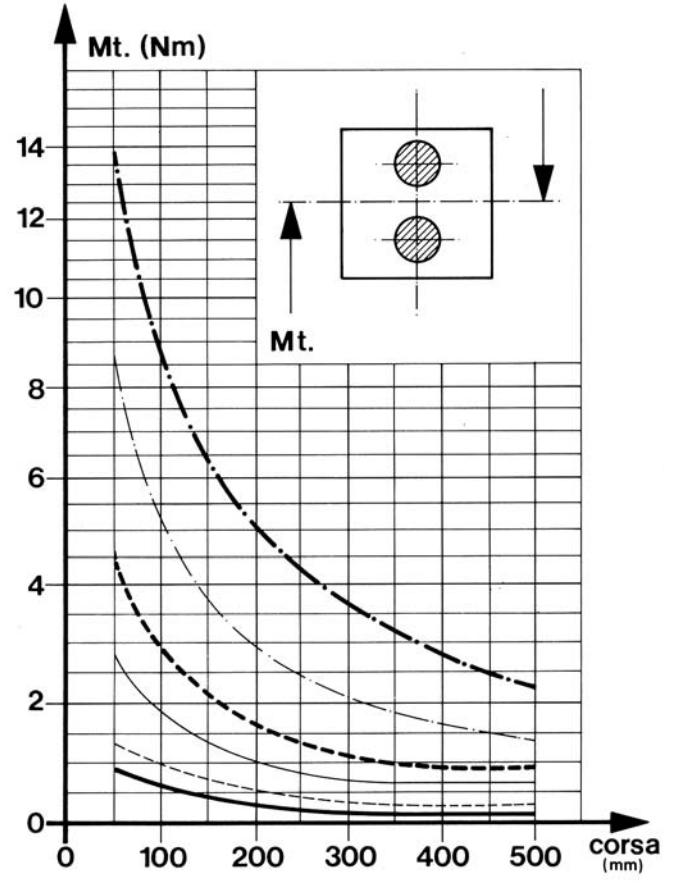

4

# bloccastelo

rod blocking device



Il bloccastelo è un dispositivo meccanico da applicare ai cilindri ISO 6431 (alesaggi da 32 a 125) e ai microcilindri ISO 6432 (alesaggi da 12 a 25).

È costituito da un sistema di due ganasce contrapposte che, sotto l'azione di molle opportunamente dimensionate, si oppongono allo scorrimento dello stelo del cilindro. Inviando un comando pneumatico l'azione delle molle viene neutralizzata e il cilindro si sblocca.

Pertanto è possibile posizionare il cilindro in punti intermedi della corsa o bloccarlo in caso di cadute di pressione.

*The rod blocking device can be used with cylinders ISO 6431 (bores from 32 to 125) and with minicylinders ISO 6432 (bores from 12 to 25).*

*The device is normally locked. It is unlocked by applying a pneumatic signal. Therefore it is possible to block the cylinder in case of pressure drop or to stop the movement in intermediate positions.*



## Materiali

Corpo: alluminio anodizzato

Ganasce di bloccaggio: ottone

Pistoni: resina acetica

Molle: acciaio armonico

## Materials

Body: aluminium (anodize treatment)

Internal parts: brass

Pistons: polymer

Springs: steel

Pressione minima di pilotaggio <i>Minimum actuating pressure</i>	3 bar 0.3 MPa											
Temperatura di esercizio <i>Temperature range</i>	max +60°C											
Funzionamento <i>Construction type</i>	Meccanico bidirezionale <i>Mechanical bi-directional</i>											
Tipologia <i>Function</i>	NC (sblocco a comando pneumatico) <i>NC (pneumatic piloted unlock)</i>											
Forza di bloccaggio <i>Locking force</i>	∅	12	16	20	25	32	40	50	63	80	100	125
	forza (N) <i>force (N)</i>	200	200	490	490	790	1240	1930	3060	5400	7700	12040
Fluido <i>Fluid</i>	Aria filtrata 50μ con o senza lubrificazione <i>50μ filtered, lubricated or non lubricated air</i>											

## versione per microcilindri ISO 6432

version for minicylinders ISO 6432

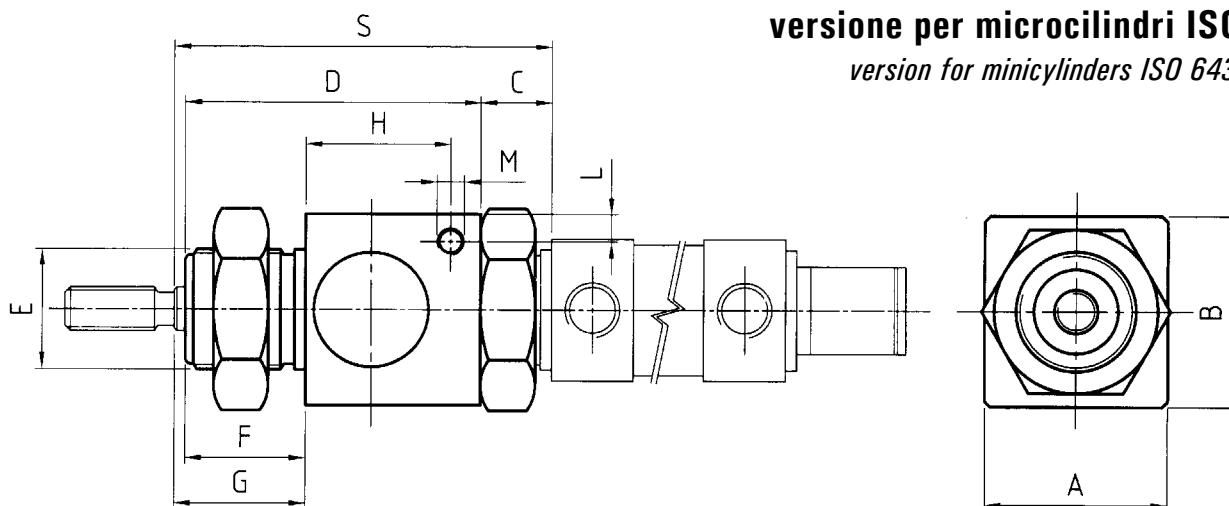

modello model	per alesaggi for bores	A	B	C	D	E	F	G	H	L	M
<b>BM012</b>	12-16	30	29.5	10.5	44.5	M16x1.5	17	22	24.5	4	M5
<b>BM020</b>	20	35	33.5	13	54	M22x1.5	22	24	26.5	4.5	M5
<b>BM025</b>	25	35	33.5	13	54	M22x1.5	22	28	26.5	4.5	M5

## versione per cilindri ISO 6431

version for cylinders ISO 6431

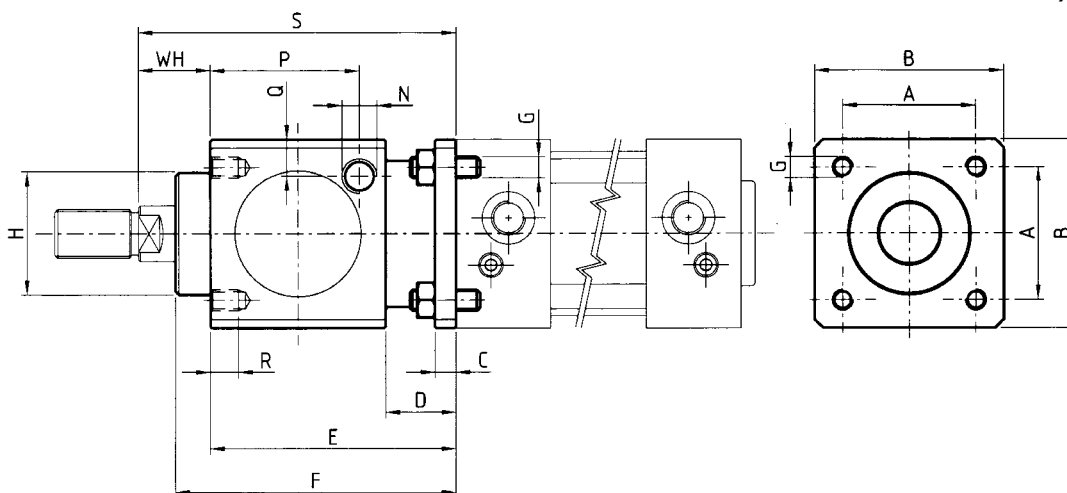

modello model	per alesaggi for bores	A	B	C	D	E	F	G	H	WH	N	P	Q	R	S
<b>BM032</b>	32	32.5	47	6	22.5	60	67.5	M6	30	26	G1/8"	33.5	9.5	8	86
<b>BM040</b>	40	38	54	6	20	70	80	M6	35	30	G1/8"	42.5	10.5	8	100
<b>BM050</b>	50	46.5	65	8	24	90	100	M8	40	32	G1/8"	58	12.5	12	122
<b>BM063</b>	63	56.5	75	8	24	90	100	M8	45	37	G1/8"	59	17.5	12	127
<b>BM080</b>	80	72	95	12	32	110	120	M10	45	46	G1/4"	69	17.5	16	156
<b>BM100</b>	100	89	114	12	32	110	120	M10	55	51	G1/4"	69	27	16	161
<b>BM125</b>	125	110	140	20	45	140	156	M12	60	65	G1/4"	84.5	20	20	205

## schema di montaggio instructions for installation

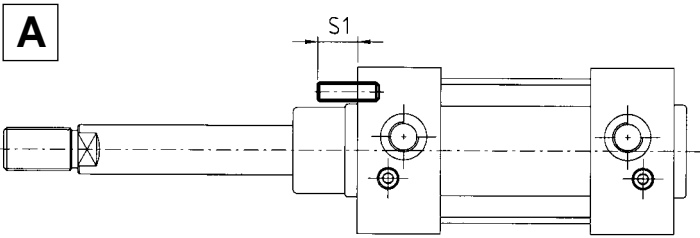

CILINDRO Ø	32	40	50	63	80	100	125
S1	12	12	16	16	22	22	32

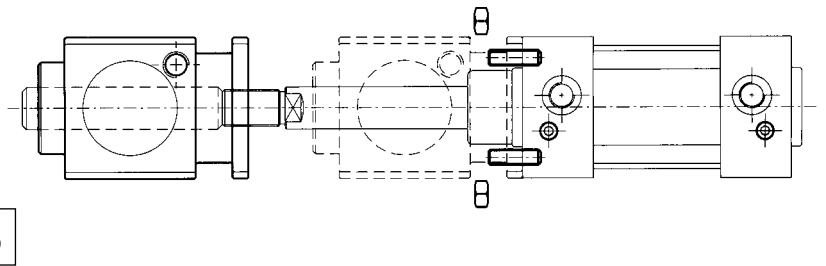

## schema di collegamento connection scheme

### comando pneumatico pneumatic control

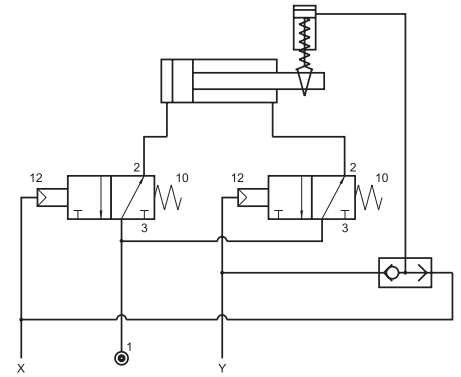
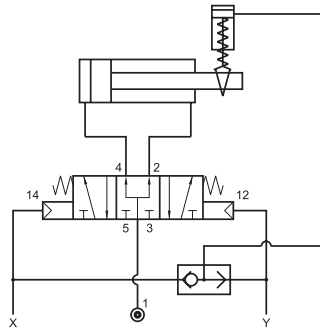

### comando elettropneumatico electropneumatic control

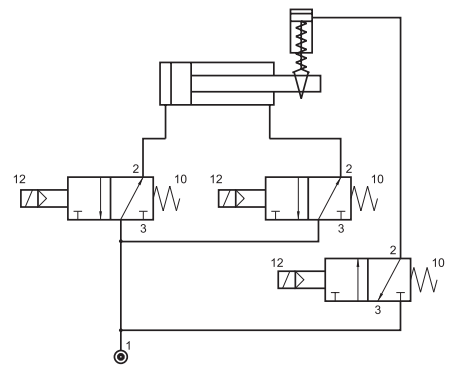
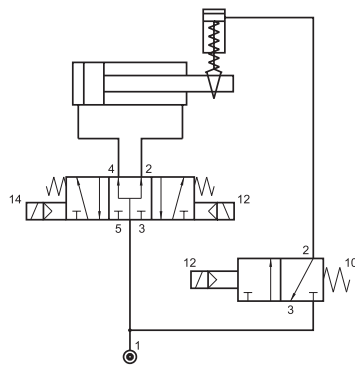

## FORCELLE

forks

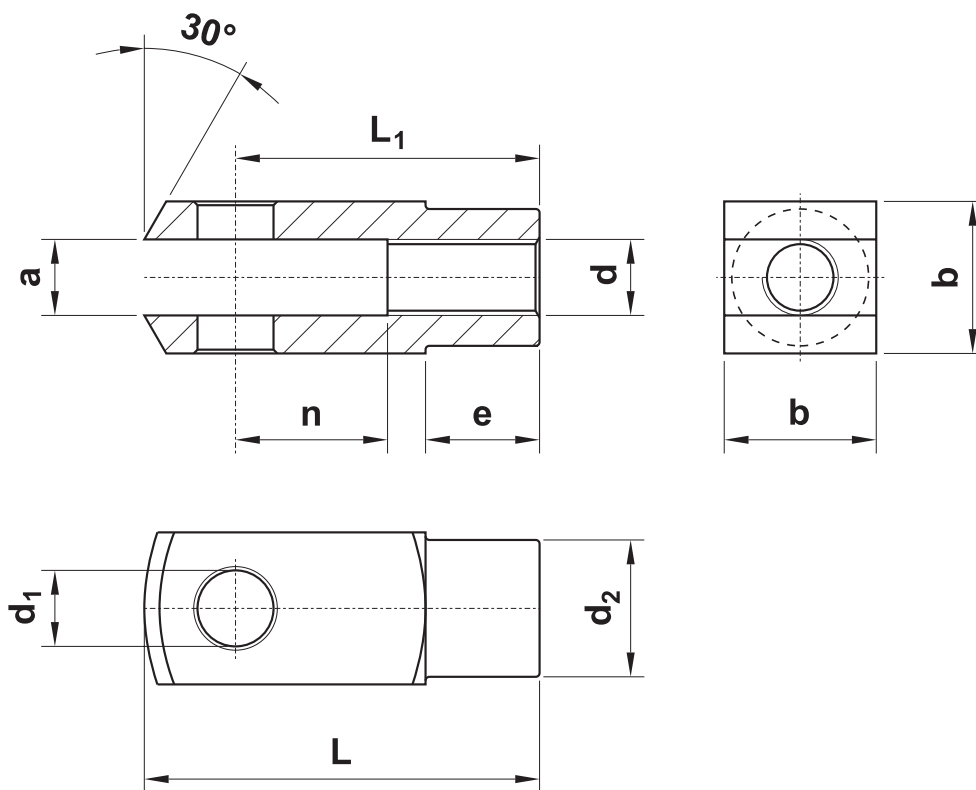

modello model	per alesaggi for bores	d	a	b	d <sub>1</sub>	d <sub>2</sub>	e	L	L <sub>1</sub>	n	fornita con it is supplied with
<b>FR8C10</b>	8-10	M4x0.7	4	8	ø4	ø8	6	21	16	8	clip
<b>FR12C16</b>	12-16	M6x1	6	12	ø6	ø10	9	31	24	12	clip
<b>FRC20</b>	20	M8x1.25	8	16	ø8	ø14	12	42	32	16	clip
<b>FR25C32</b>	25-32	M10x1.25	10	20	ø10	ø18	15	52	40	20	clip
<b>FRC40</b>	40	M12x1.25	12	24	ø12	ø20	18	62	48	24	clip
<b>FR50C63</b>	50-63	M16x1.5	16	32	ø16	ø26	24	83	64	32	clip
<b>FR80C100</b>	80-100	M20x1.5	20	40	ø20	ø34	30	105	80	40	clip
<b>FRC125</b>	125	M27x2	30	55	ø30	ø48	38	148	110	54	perno [pin]
<b>FR160C200</b>	160-200	M36x2	35	70	ø35	ø60	40	188	144	72	perno [pin]

## CLIPS PER FORCELLE

clips for forks

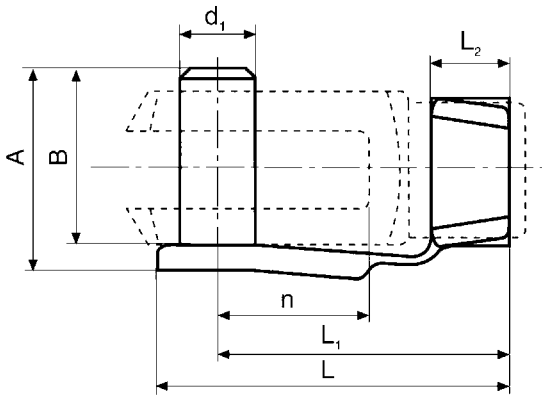

usata per forcella it is used for fork	d <sub>1</sub>	n	A	B	L	L <sub>1</sub>	L <sub>2</sub>
<b>M4x0.7</b>	4	8	11	9	19	15	5
<b>M6x1</b>	6	12	16	14	28	23	6
<b>M8x1.25</b>	8	16	22	19	37	31	8
<b>M10x1.25</b>	10	20	26	23	46	39	10
<b>M12x1.25</b>	12	24	32	28	55	47	12
<b>M16x1.5</b>	16	32	40	36	72	62	14
<b>M20x1.5</b>	20	40	48	44	88	72	16

## PERNI PER FORCELLE

pins for forks

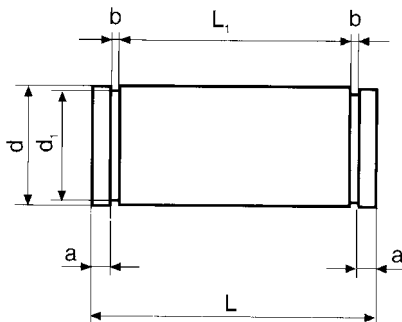

usato per forcella it is used for fork	d	L	d <sub>1</sub>	L <sub>1</sub>	a	b
<b>M27x2</b>	30	65	28.6	55	3.4	1.6
<b>M36x2</b>	35	84	33.4	70	5.4	1.6

## DADI PER STELO

nuts for piston-rod



sigla part number	codice code	per alesaggio for bore	filetto thread	chiave key
<b>DSMC8-10</b>	26.196.2	8-10	M4x0.7	7
<b>DSMC12-16</b>	26.197.2	12-16	M6x1	10
<b>DSMC20</b>	26.198.2	20	M8x1.25	13
<b>DSIS032</b>	21.750.0	25-32	M10x1.25	17
<b>DSIS040</b>	21.751.0	40	M12x1.25	19
<b>DSIS05063</b>	21.752.0	50-63	M16x1.5	24
<b>DSIS080100</b>	21.753.0	80-100	M20x1.5	30
<b>DSIS125</b>	21.754.0	125	M27x2	41
<b>DSIS160200</b>	21.755.0	160-200	M36x2	55

## TESTE A SNODO

jointing balls

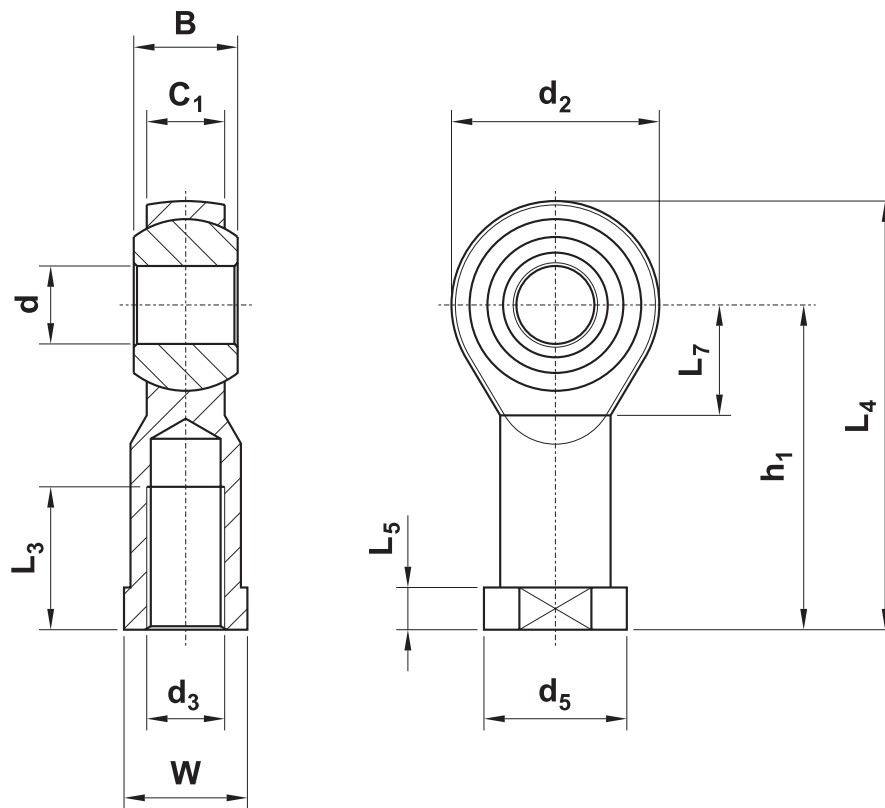

modello model	per alesaggi for bores	d <sub>3</sub>	d	B	C <sub>1</sub>	d <sub>2</sub>	d <sub>5</sub>	h <sub>1</sub>	L <sub>3</sub>	L <sub>4</sub>	L <sub>5</sub>	L <sub>7</sub>	W
TS8T10	8-10	M4x0.7	ø5	8	6	18	ø11	27	10	36	4	10	9
TS12T16	12-16	M6x1	ø6	9	6.75	20	ø13	30	12	40	5	11	11
TST20	20	M8x1.25	ø8	12	9	24	ø16	36	16	48	5	13	14
TS25T32	25-32	M10x1.25	ø10	14	10.5	28	ø19	43	20	57	6.5	15	17
TST40	40	M12x1.25	ø12	16	12	32	ø22	50	22	66	6.5	17	19
TS50T63	50-63	M16x1.5	ø16	21	15	42	ø27	64	28	85	8	23	22
TS80T100	80-100	M20x1.5	ø20	25	18	50	ø34	77	33	102	10	27	30
TST125	125	M27x2	ø30	37	25	70	ø50	110	51	145	15	36	41
TS160T200	160-200	M36x2	ø35	43	28	80	ø58	125	56	165	17	41	50

## SNODI AUTOALLINEANTI

self-aligning joints

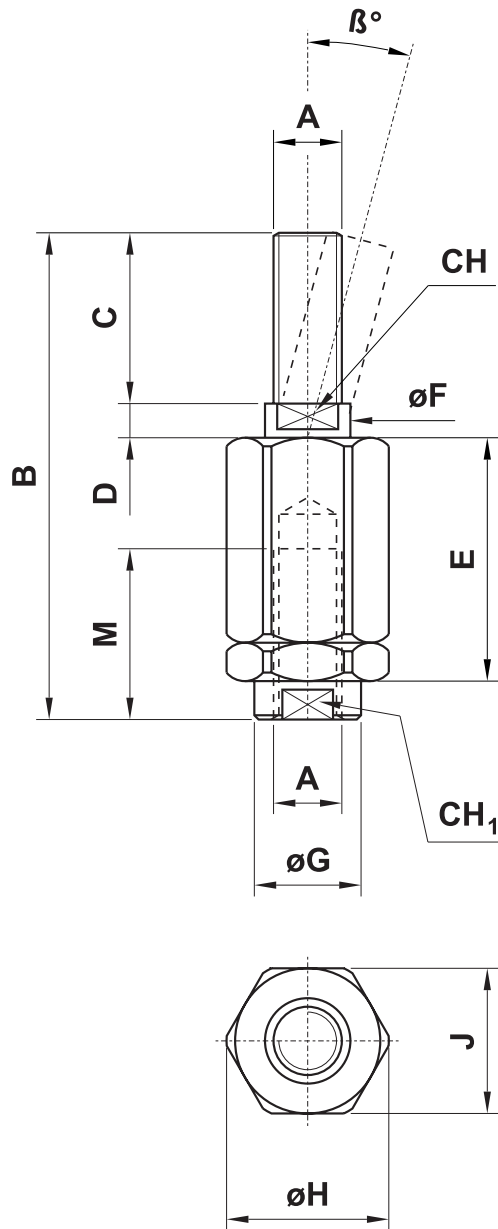

modello model	per alesaggi for bores	A	B	C	D	E	F	G	H	J	M	CH	β°	CH <sub>1</sub>
<b>SN12D16</b>	12-16	M6x1	35	10	3.5	17.5	6	8.5	14.5	13	10	5	10	7
<b>SND20</b>	20	M8x1.25	57	20	4	28.5	8	12.5	19	17	20	7	10	11
<b>SN25D32</b>	25-32	M10x1.25	71	20	5	35	14	22	32	30	20	12	10	19
<b>SND40</b>	40	M12x1.25	75	24	5	35	14	22	32	30	20	12	10	19
<b>SN50D63</b>	50-63	M16x1.5	103	32	8	54	22	32	45	41	32	20	10	30
<b>SN80D100</b>	80-100	M20x1.5	119	40	8	54	22	32	45	41	40	20	10	30





- Unità di guida per cilindri ISO 6431 e microcilindri ISO 6432  
*Guiding units for cylinders ISO 6431 and minicylinders ISO 6432*
- Versioni disponibili: tipo "U" con bronzine (cod. **UB...**) - per cilindri da alesaggio 12 a 100  
tipo "H" con bronzine (cod. **HB...**) - per cilindri da alesaggio 12 a 100  
tipo "H" con cuscinetti a rotolamento (cod. **HS...**) - per cilindri da alesaggio 12 a 100  
*Available versions: type "U" with sintered bronze rod guide (code **UB...**) - cylinder bores from 12 to 100  
type "H" with sintered bronze rod guide (code **HB...**) - cylinder bores from 12 to 100  
type "H" with linear ball bearings (code **HS...**) - cylinder bores from 12 to 100*
- Tipo "U" con bronzine: movimentazione con carichi medi e basse velocità  
*Type "U" with sintered bronze rod guide: movements with medium loads and low speeds*
- Tipo "H" con bronzine: movimentazione con carichi alti e basse velocità  
*Type "H" with sintered bronze rod guide: movements with heavy loads and low speeds*
- Tipo "H" con cuscinetti a rotolamento: movimentazione con carichi medi e alte velocità  
*Type "H" with linear ball bearings: movements with medium loads and high speeds*

## Materiali

Corpo: alluminio anodizzato

Steli: C40 cromato

## Materials

Body: aluminium (anodize treatment)

Rods: C40 (chromium plated)

## chiave di codifica

key to codes

**H B 0 8 0 C 1 5 0**

tipo  
type

guida stelo  
rod guide

corsa  
stroke

alesaggio cilindro  
cylinder bore

### Tipo [type]

**H** tipo "H" [type "H"]

**U** tipo "U" [type "U"]

### Guida stelo [rod guide]

**B** bronzine [sintered bronze]

**S** cuscinetti a rotolamento [linear ball bearings]

## alesaggi e corse disponibili

available bores and strokes

alesaggio corsa bore stroke	12* 16	20	25	32	40	50	63	80	100
50	X	X	X	X	X	X	X	X	X
100	X	X	X	X	X	X	X	X	X
150				X	X	X	X	X	X
160	X	X	X						
200	X	X	X	X	X	X	X	X	X
250	X	X	X	X	X	X	X	X	X
300				X	X	X	X	X	X
400				X	X	X	X	X	X
500				X	X	X	X	X	X

\* L'unità di guida per l'alesaggio 12 si utilizza anche per l'alesaggio 16. Il codice rimane quello dell'alesaggio 12.

\* The guiding unit for bore 12 is used also for bore 16, with the same code.

## Carico ammissibile / Permissible loads

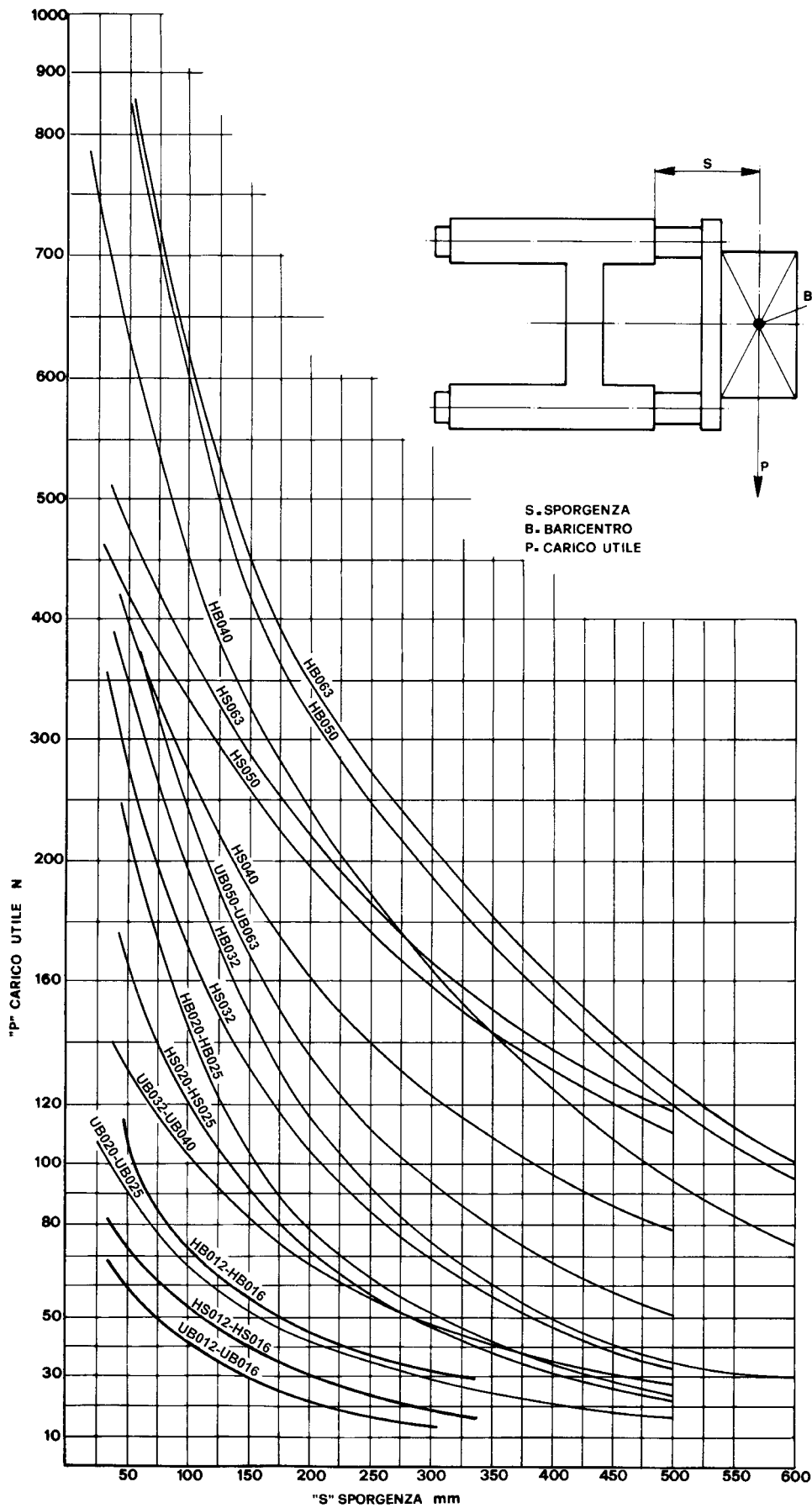

## tipo "U" per microcilindri ISO 6432

type "U" for minicylinders ISO 6432

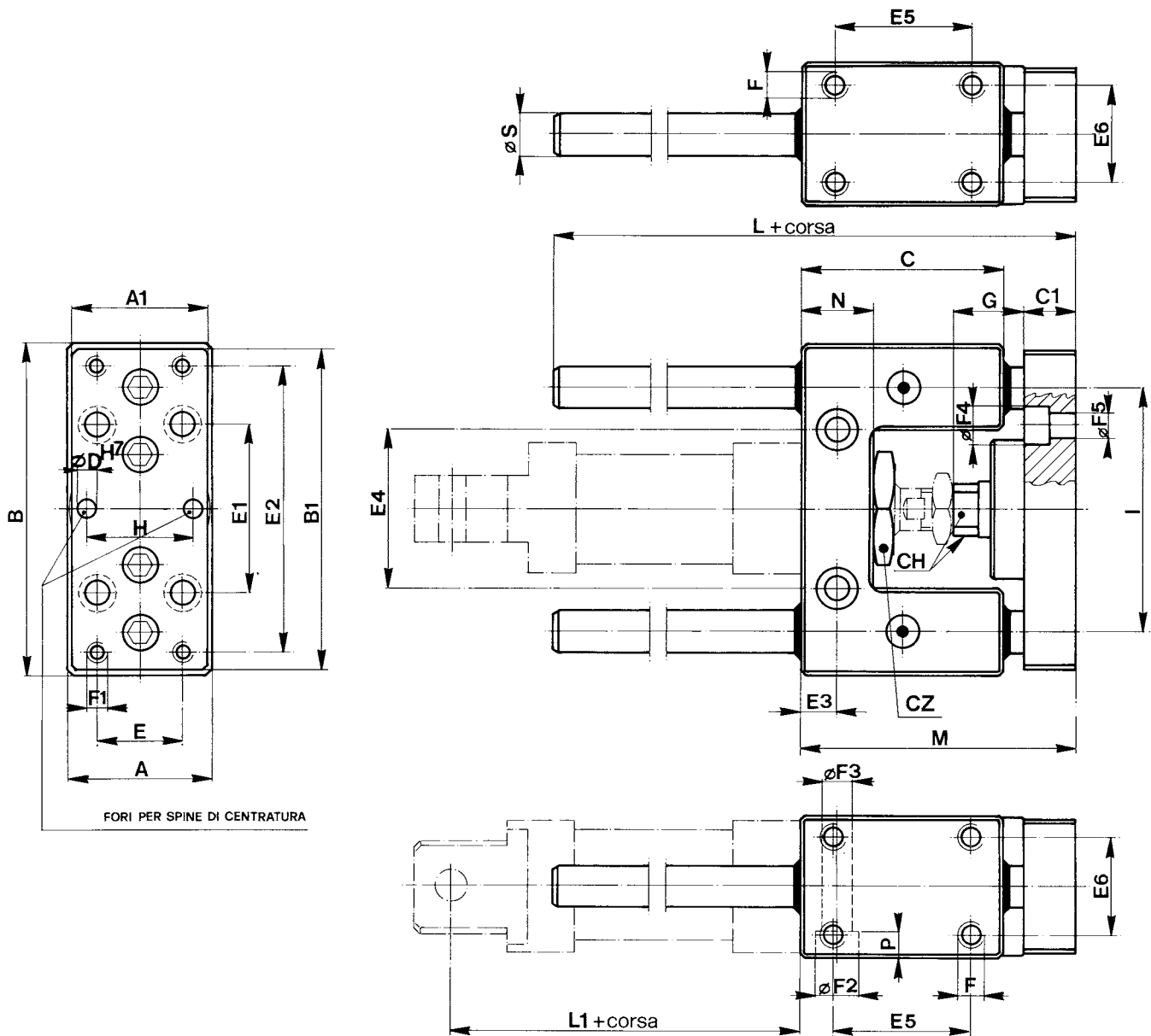

FORI PER SPINE DI CENTRATURA

ø CIL	A	A1	B	B1	C	C1	CH	CZ	D	E	E1	E2	E3	E4	E5	E6	F	F1	F2	F3	F4	F5	G	H	I	L	L1	M	N	P	S
12 16	30	27	65	63	38	10	8	19	4	15	32	54	6.5	24	25	22	M4	M4	8.5	5.1	7.5	4.5	12	15	46	70	53	51	13	5.5	8
																											60				
20	34	32	79	76	48	12	12	27	6	20	40	68	8.5	38	32.5	23	M6	M5	10.5	6.5	9	5.5	22	20	58	83	71	65	17	6.5	10
25	34	32	79	76	48	12	12	27	6	20	40	68	8.5	38	32.5	23	M6	M5	10.5	6.5	9	5.5	17	20	58	83	76	65	17	6.5	10

## tipo "U" per cilindri ISO 6431

type "U" for cylinders ISO 6431

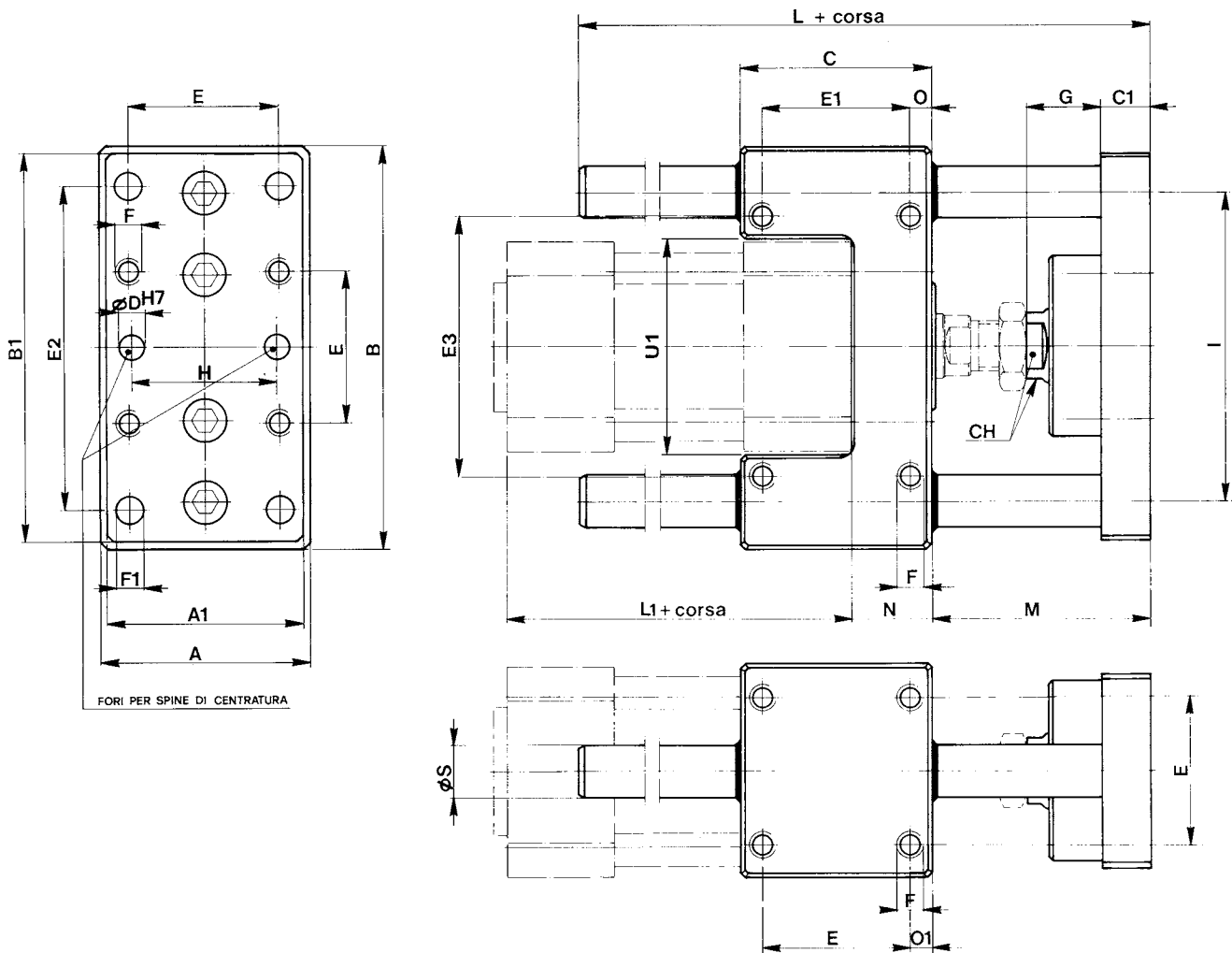

FORI PER SPINE DI CENTRATURA

$\varnothing$ CIL	A	A1	B	B1	C	C1	D	E	E1	E2	E3	F	F1	G	H	I	L	L1	M	N	O	O1	S	CH	U1
32	48	45	100	90	48	12	6	32.5	32.5	78	58	M6	6.5	20	31	74	106	94	54	17	7.8	7.8	12	13	48
40	56	50	106	105	58	12	6	38	38	84	64	M6	6.5	22	36	80	117	105	55	21	10	10	12	15	54
50	66	60	125	124	59	15	6	46.5	46.5	100	80	M8	9	23	45	96	129	106	68	25	6.3	6.3	16	21	67
63	76	70	132	125	76	15	6	56.5	56.5	105	95	M8	9	23	45	104	146	121	68	25	9.8	9.8	16	21	76
80	98	90	165	155	90	18	6	72	50	130	130	M10	11	30	56	130	170	128	78	34	20	9	20	27	97
100	118	110	185	175	110	18	6	89	70	150	150	M10	11	30	56	150	190	138	78	39	20	10.5	20	27	117

## tipo "H" per microcilindri ISO 6432

type "H" for minicylinders ISO 6432

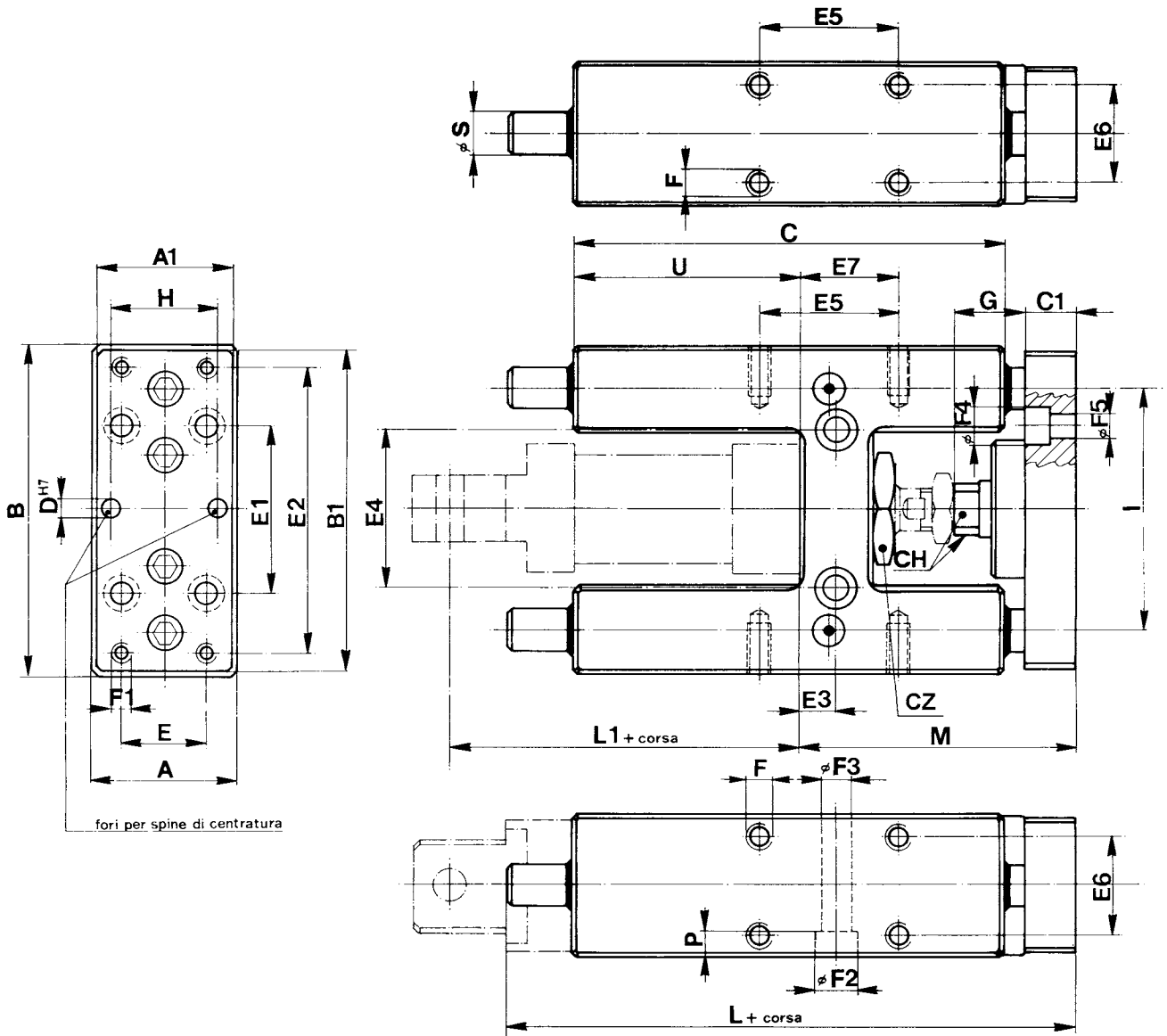

∅ CIL	A	A1	B	B1	C	C1	CH	CZ	D	E	E1	E2	E3	E4	E5	E6	E7	F	F1	F2	F3	F4	F5	G	H	I	L	L1	M	P	S	U
12 16	30	27	65	63	75	10	8	19	4	15	32	54	6.5	24	32.5	22	11	M4	M4	8.5	5.1	7.5	4.5	12	15	46	130	53	51	5.5	8	37
																												60				
20	34	32	79	76	108	12	12	27	6	20	40	68	8.5	38	32.5	23	15	M6	M5	10.5	6.5	9	5.5	22	20	58	159	71	65	6.5	10	58
25	34	32	79	76	108	12	12	27	6	20	40	68	8.5	38	32.5	23	15	M6	M5	10.5	6.5	9	5.5	17	20	58	159	76	65	6.5	10	58

## tipo "H" per cilindri ISO 6431

type "H" for cylinders ISO 6431

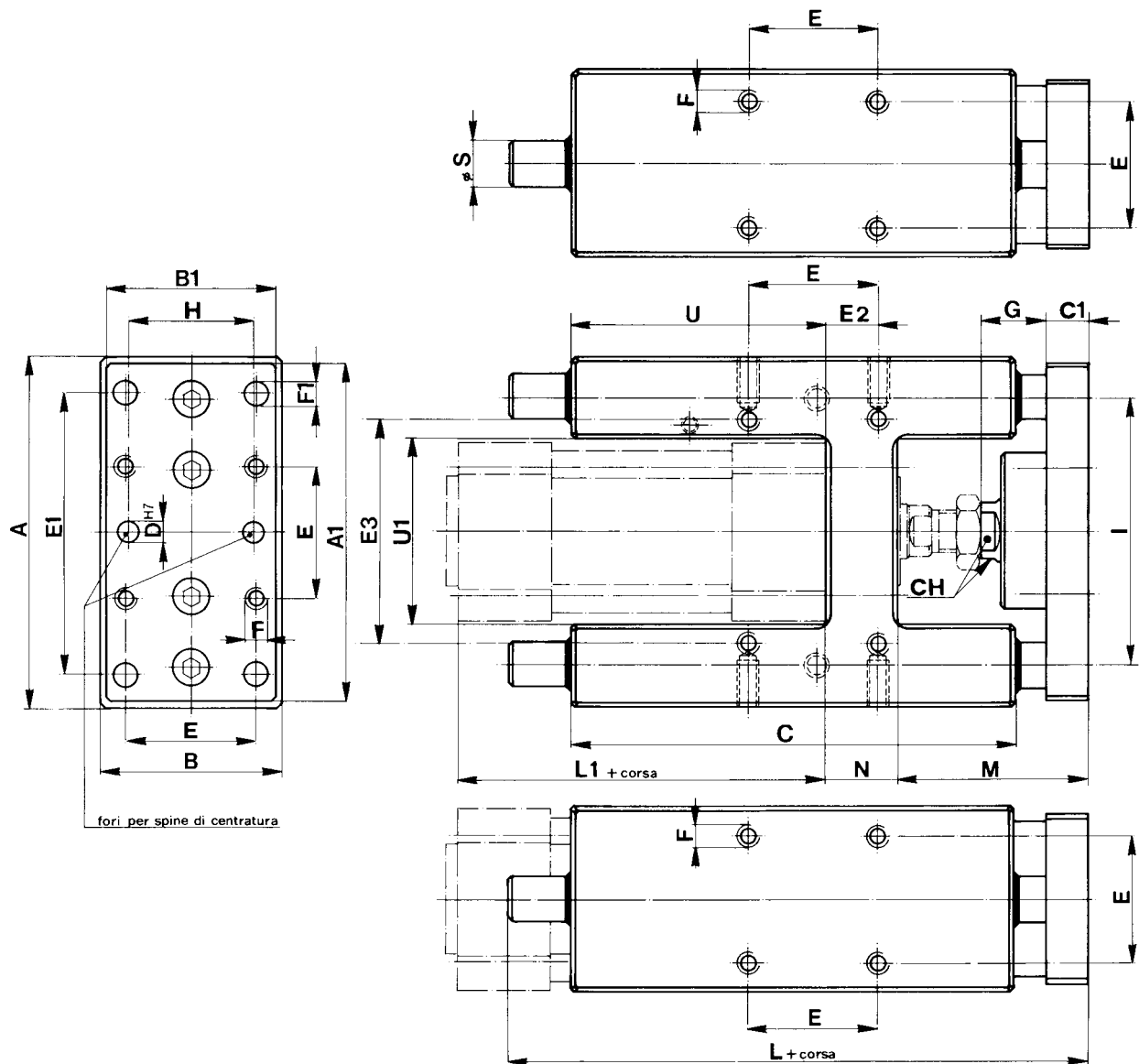

∅ CIL	A	A1	B	B1	C	C1	CH	D	E	E1	E2	E3	F	F1	G	H	I	L	L1	M	N	S	U	U1
32	97	90	50	45	125	12	13	6	32.5	78	4.3	61	M6	6.5	20	31	74	177	94	54	17	12	76	50.5
40	115	105	58	50	136	12	15	6	38	84	11	69	M6	6.5	22	36	87	192	105	55	21	16	81	58.5
50	137	124	70	60	144	15	21	6	46.5	100	18.5	85	M8	9	23	45	104	237	106	68	26	20	79	70.5
63	152	145	85	70	176	15	21	6	56.5	105	15.3	100	M8	9	23	45	119	237	121	68	26	20	111	85.5
80	189	180	105	100	215	20	27	6	72	130	21	130	M10	11	30	56	148	280	128	78	34	25	128	106
100	213	200	130	120	220	20	27	6	89	150	24.5	150	M10	11	30	56	173	280	138	78	39	25	128	131



- Unità di guida per cilindri ISO 6431 e microcilindri ISO 6432  
*Guiding units for cylinders ISO 6431 and minicylinders ISO 6432*
- Versioni disponibili: tipo "U" con bronzine (cod. **UB**...) - per cilindri da alesaggio 12 a 100  
tipo "H" con bronzine (cod. **HB**...) - per cilindri da alesaggio 12 a 100  
tipo "H" con cuscinetti a rotolamento (cod. **HS**...) - per cilindri da alesaggio 12 a 100  
*Available versions: type "U" with sintered bronze rod guide (code **UB**...) - cylinder bores from 12 to 100  
type "H" with sintered bronze rod guide (code **HB**...) - cylinder bores from 12 to 100  
type "H" with linear ball bearings (code **HS**...) - cylinder bores from 12 to 100*
- Tipo "U" con bronzine: movimentazione con carichi medi e basse velocità  
*Type "U" with sintered bronze rod guide: movements with medium loads and low speeds*
- Tipo "H" con bronzine: movimentazione con carichi alti e basse velocità  
*Type "H" with sintered bronze rod guide: movements with heavy loads and low speeds*
- Tipo "H" con cuscinetti a rotolamento: movimentazione con carichi medi e alte velocità  
*Type "H" with linear ball bearings: movements with medium loads and high speeds*

## Materiali

Corpo: alluminio anodizzato

Steli: C40 cromato

## Materials

Body: aluminium (anodize treatment)

Rods: C40 (chromium plated)

## chiave di codifica

key to codes

**H B 0 8 0 C 1 5 0**

tipo  
type

guida stelo  
rod guide

corsa  
stroke

alesaggio cilindro  
cylinder bore

### Tipo [type]

**H** tipo "H" [type "H"]

**U** tipo "U" [type "U"]

### Guida stelo [rod guide]

**B** bronzine [sintered bronze]

**S** cuscinetti a rotolamento [linear ball bearings]

## alesaggi e corse disponibili

available bores and strokes

alesaggio corsa bore stroke	12* 16	20	25	32	40	50	63	80	100
50	X	X	X	X	X	X	X	X	X
100	X	X	X	X	X	X	X	X	X
150				X	X	X	X	X	X
160	X	X	X						
200	X	X	X	X	X	X	X	X	X
250	X	X	X	X	X	X	X	X	X
300				X	X	X	X	X	X
400				X	X	X	X	X	X
500				X	X	X	X	X	X

\* L'unità di guida per l'alesaggio 12 si utilizza anche per l'alesaggio 16. Il codice rimane quello dell'alesaggio 12.

\* The guiding unit for bore 12 is used also for bore 16, with the same code.

## Carico ammissibile / Permissible loads

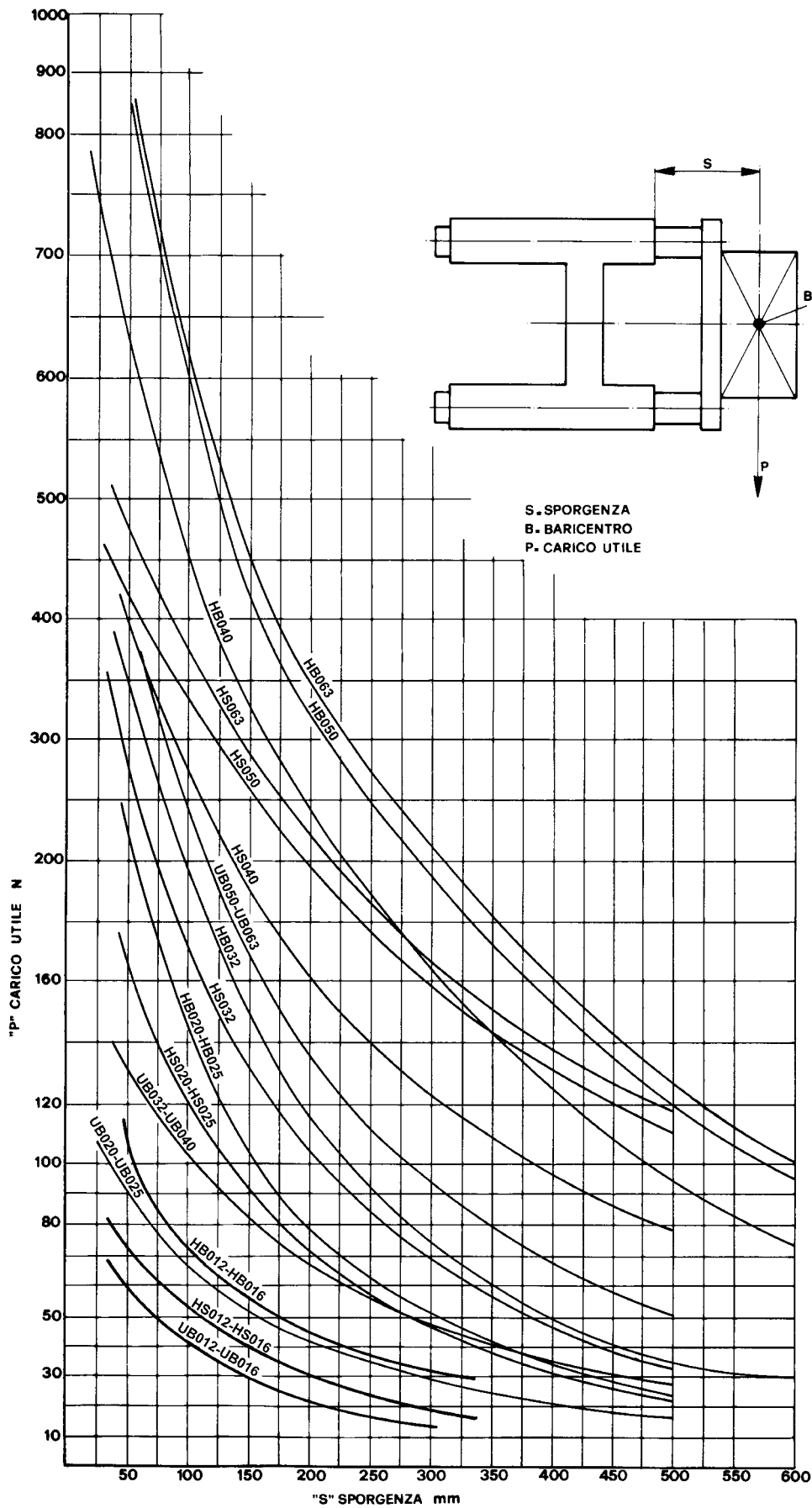



## tipo "U" per microcilindri ISO 6432

type "U" for minicylinders ISO 6432

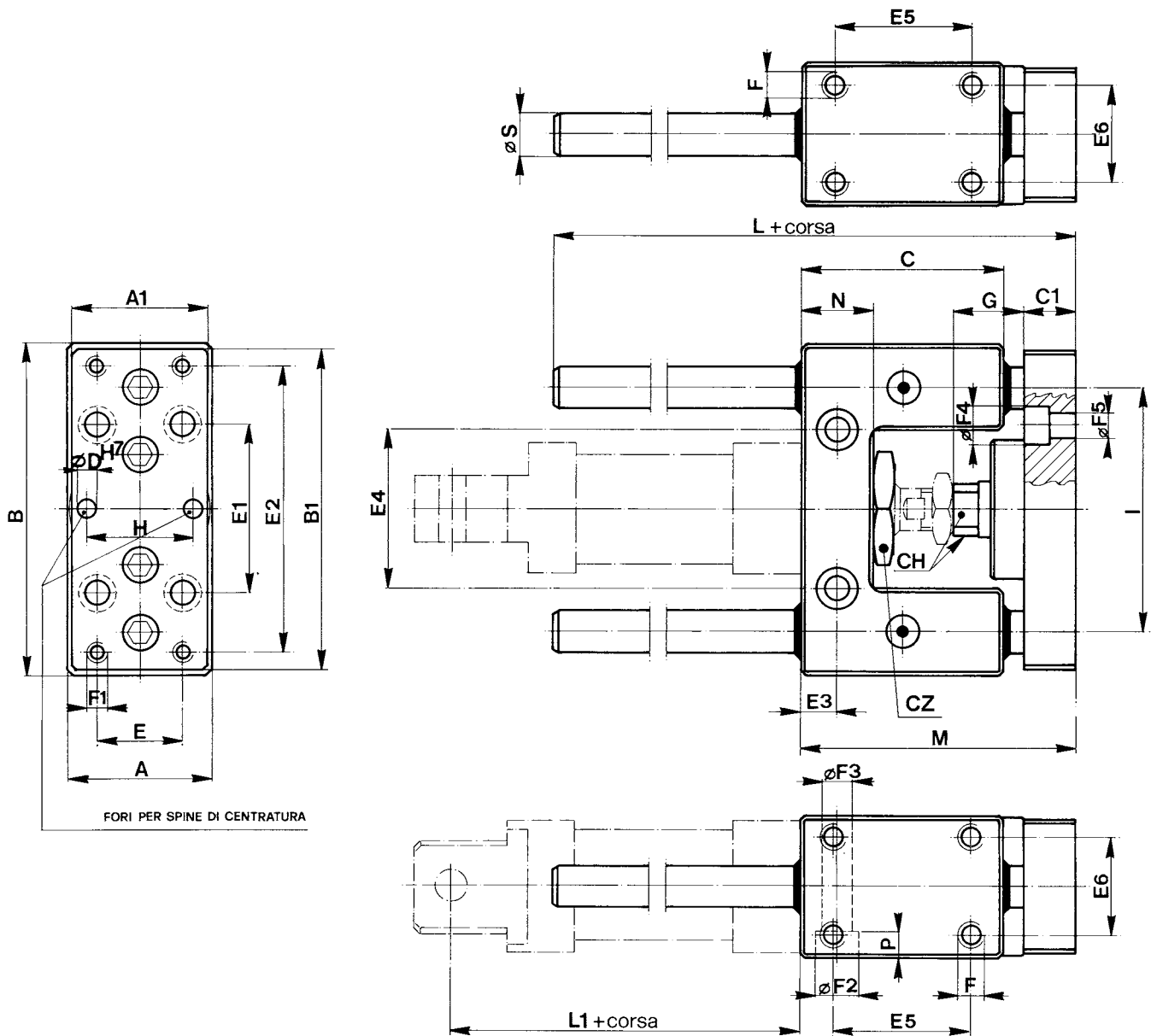

FORI PER SPINE DI CENTRATURA

ø CIL	A	A1	B	B1	C	C1	CH	CZ	D	E	E1	E2	E3	E4	E5	E6	F	F1	F2	F3	F4	F5	G	H	I	L	L1	M	N	P	S
12 16	30	27	65	63	38	10	8	19	4	15	32	54	6.5	24	25	22	M4	M4	8.5	5.1	7.5	4.5	12	15	46	70	53	51	13	5.5	8
																											60				
20	34	32	79	76	48	12	12	27	6	20	40	68	8.5	38	32.5	23	M6	M5	10.5	6.5	9	5.5	22	20	58	83	71	65	17	6.5	10
25	34	32	79	76	48	12	12	27	6	20	40	68	8.5	38	32.5	23	M6	M5	10.5	6.5	9	5.5	17	20	58	83	76	65	17	6.5	10

## tipo "U" per cilindri ISO 6431

type "U" for cylinders ISO 6431

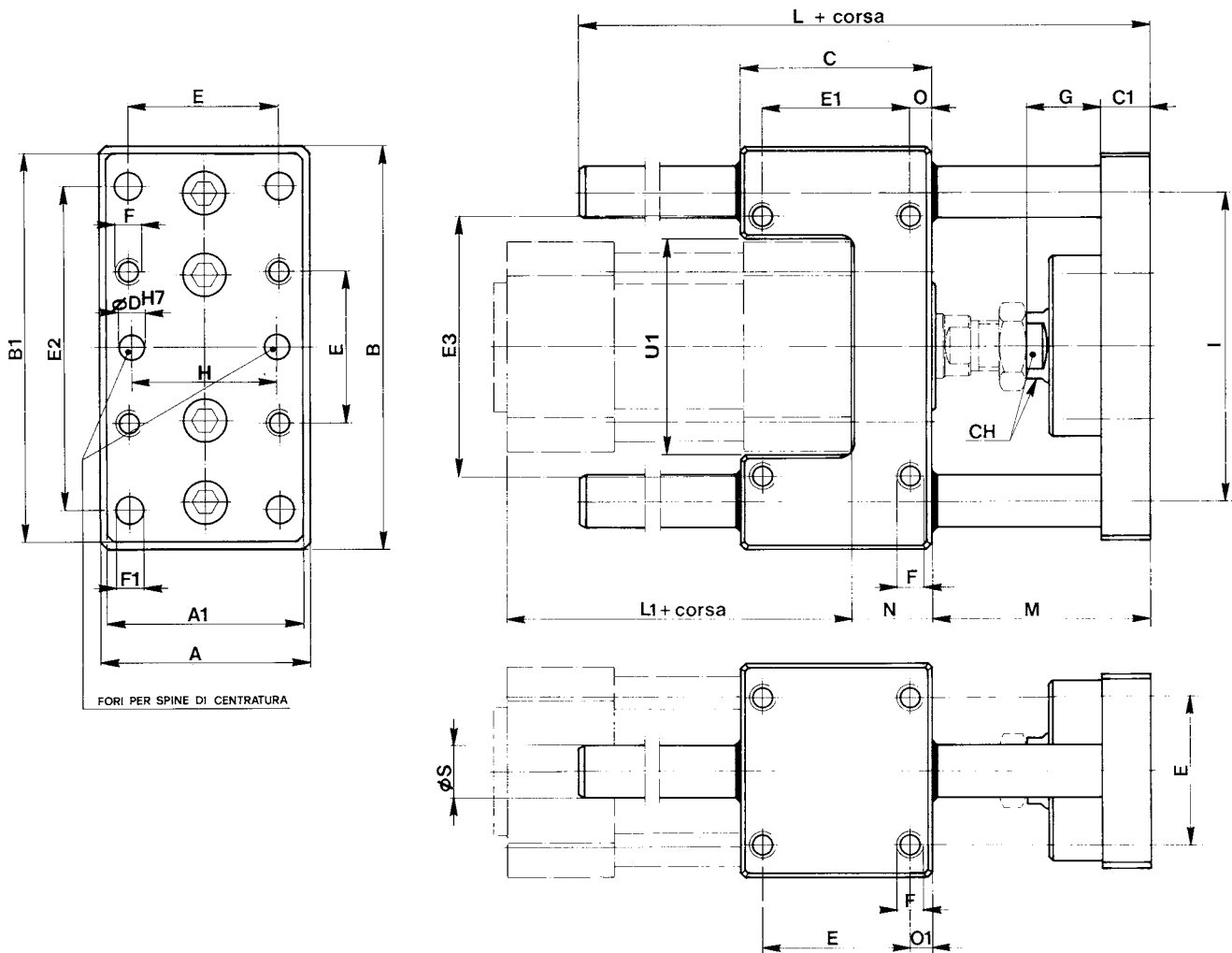

FORI PER SPINE DI CENTRATURA

$\varnothing$ CIL	A	A1	B	B1	C	C1	D	E	E1	E2	E3	F	F1	G	H	I	L	L1	M	N	O	O1	S	CH	U1
32	48	45	100	90	48	12	6	32.5	32.5	78	58	M6	6.5	20	31	74	106	94	54	17	7.8	7.8	12	13	48
40	56	50	106	105	58	12	6	38	38	84	64	M6	6.5	22	36	80	117	105	55	21	10	10	12	15	54
50	66	60	125	124	59	15	6	46.5	46.5	100	80	M8	9	23	45	96	129	106	68	25	6.3	6.3	16	21	67
63	76	70	132	125	76	15	6	56.5	56.5	105	95	M8	9	23	45	104	146	121	68	25	9.8	9.8	16	21	76
80	98	90	165	155	90	18	6	72	50	130	130	M10	11	30	56	130	170	128	78	34	20	9	20	27	97
100	118	110	185	175	110	18	6	89	70	150	150	M10	11	30	56	150	190	138	78	39	20	10.5	20	27	117

## tipo "H" per microcilindri ISO 6432

type "H" for minicylinders ISO 6432

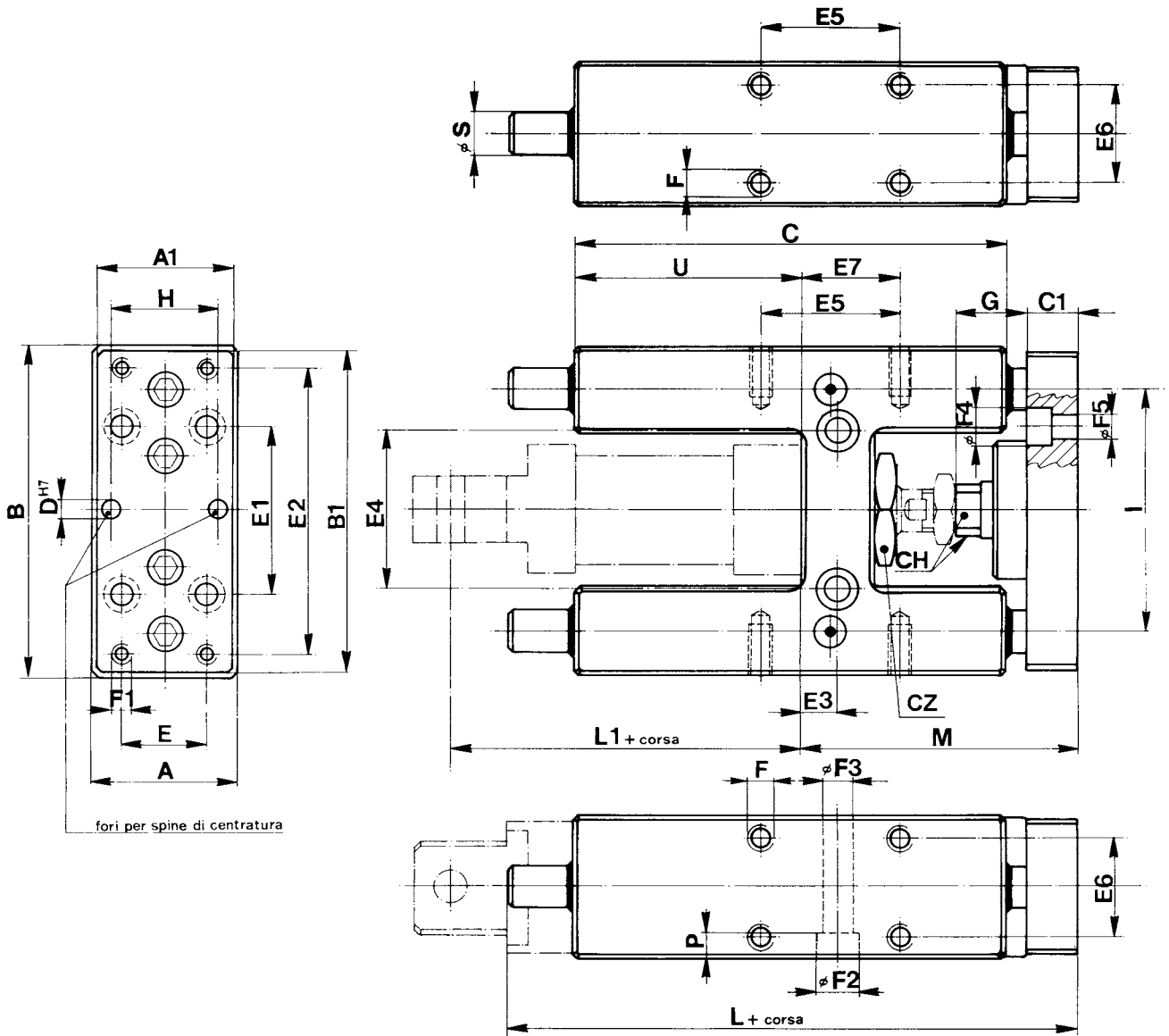

∅ CIL	A	A1	B	B1	C	C1	CH	CZ	D	E	E1	E2	E3	E4	E5	E6	E7	F	F1	F2	F3	F4	F5	G	H	I	L	L1	M	P	S	U
12 16	30	27	65	63	75	10	8	19	4	15	32	54	6.5	24	32.5	22	11	M4	M4	8.5	5.1	7.5	4.5	12	15	46	130	53	51	5.5	8	37
																												60				
20	34	32	79	76	108	12	12	27	6	20	40	68	8.5	38	32.5	23	15	M6	M5	10.5	6.5	9	5.5	22	20	58	159	71	65	6.5	10	58
25	34	32	79	76	108	12	12	27	6	20	40	68	8.5	38	32.5	23	15	M6	M5	10.5	6.5	9	5.5	17	20	58	159	76	65	6.5	10	58

## tipo "H" per cilindri ISO 6431

type "H" for cylinders ISO 6431

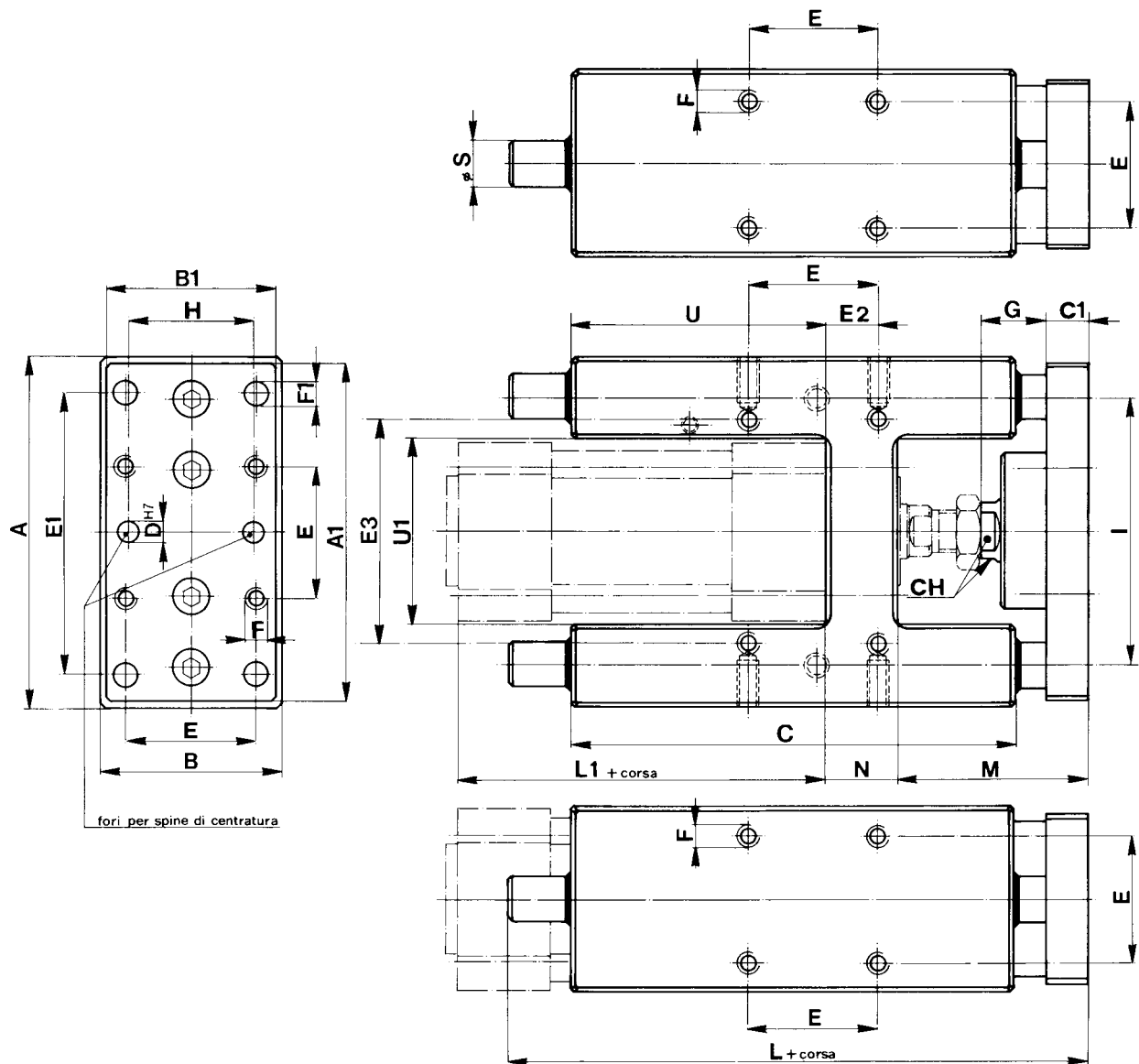

∅ CIL	A	A1	B	B1	C	C1	CH	D	E	E1	E2	E3	F	F1	G	H	I	L	L1	M	N	S	U	U1
32	97	90	50	45	125	12	13	6	32.5	78	4.3	61	M6	6.5	20	31	74	177	94	54	17	12	76	50.5
40	115	105	58	50	136	12	15	6	38	84	11	69	M6	6.5	22	36	87	192	105	55	21	16	81	58.5
50	137	124	70	60	144	15	21	6	46.5	100	18.5	85	M8	9	23	45	104	237	106	68	26	20	79	70.5
63	152	145	85	70	176	15	21	6	56.5	105	15.3	100	M8	9	23	45	119	237	121	68	26	20	111	85.5
80	189	180	105	100	215	20	27	6	72	130	21	130	M10	11	30	56	148	280	128	78	34	25	128	106
100	213	200	130	120	220	20	27	6	89	150	24.5	150	M10	11	30	56	173	280	138	78	39	25	128	131

# sensori per cilindri

magnetic sensors for cylinders



## Schema di collegamento: 2 fili

Wiring diagram: 2 wires

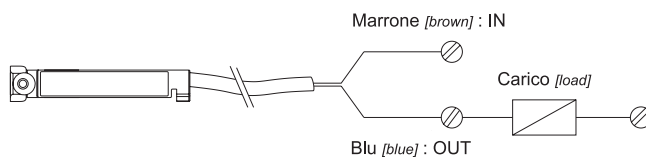

Modello Model	RS1-A	RS2-A	RS5-C	RS3-A	RS4-A
Funzione Function	Reed NA Reed NO	Reed NA Reed NO	Reed NC Reed NC	Reed NA Reed NO	Reed NA Reed NO
Numero fili Number of wires	2	2	2	2	2
Lunghezza cavo Length of wires	standard: 2 m (5 m: RS1-A 5MT)	30 cm	2 m	2 m	30 cm
Connettore Connector	-	M8	-	-	M12
Tensione di esercizio Working tension	5-130V AC-DC	5-50V AC-DC	5-130V AC-DC	5-230V AC-DC	5-230V AC-DC
Corrente massima Max. current	200 mA	200 mA	200 mA	200 mA	200 mA
Potenza massima Max. power	6 W	6 W	6 W	10 W	10 W
Caduta di tensione Tension drop	3 V	3 V	-	3 V	3 V
Segnalazione stato uscita ON Output display ON	LED giallo yellow LED	LED giallo yellow LED	LED giallo yellow LED	LED giallo yellow LED	LED giallo yellow LED
Tempo di commutazione ON IN time	0.3 ms max				
Tempo di commutazione OFF OUT time	0.1 ms max				
Frequenza massima di commutazione Max. commutation frequency	400 Hz				
Resistenza di isolamento Insulation resistance	> 100 MΩ				
Resistenza alle vibrazioni Resistance to vibrations	2 kHz				
Vita elettrica: cicli Electric life: cycles	10 <sup>7</sup>				
Temperatura di esercizio Temperature range	max +60°C				
Cavo tipo CEI 2022 II OR Cable type CEI 2022 II OR	2 x 0.14				
Grado di protezione Protection degree	IP 65				

# sensori per cilindri

magnetic sensors for cylinders



## Schema di collegamento: 3 fili

Wiring diagram: 3 wires

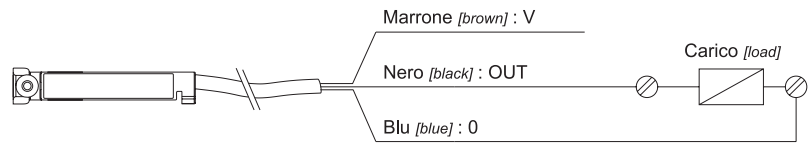

Modello Model	RS6-3F	RS7-3F	SH1-P	SH2-P
Funzione Function	Reed NA Reed NO 	Reed NA Reed NO 	Hall PNP Hall PNP 	Hall PNP Hall PNP 
Numero fili Number of wires	3	3	3	3
Lunghezza cavo Length of wires	2 m	30 cm	2 m	30 cm
Connettore Connector	-	M8	-	M8
Tensione di esercizio Working tension	5-30V AC-DC	5-30V AC-DC	5-30V DC	5-30V DC
Corrente massima Max. current	500 mA	500 mA	200 mA	200 mA
Potenza massima Max. power	6 W	6 W	4 W	4 W
Caduta di tensione Tension drop	0.1 V	0.1 V	0.7 V max	0.7 V max
Segnalazione stato uscita ON Output display ON	LED giallo yellow LED	LED giallo yellow LED	LED giallo yellow LED	LED giallo yellow LED
Tempo di commutazione ON IN time	0.3 ms max		0.8 ms max	
Tempo di commutazione OFF OUT time	0.1 ms max		0.3 ms max	
Frequenza massima di commutazione Max. commutation frequency	400 Hz		1 kHz	
Resistenza di isolamento Insulation resistance	> 100 MΩ		> 100 MΩ	
Resistenza alle vibrazioni Resistance to vibrations	2 kHz		2 kHz	
Vita elettrica: cicli Electric life: cycles	10 <sup>7</sup>		10 <sup>11</sup>	
Temperatura di esercizio Temperature range	max +60°C		max +60°C	
Cavo tipo CEI 2022 II OR Cable type CEI 2022 II OR	3 x 0.14		3 x 0.14	
Grado di protezione Protection degree	IP 65		IP 65	

## Dimensioni di ingombro

Overall dimensions

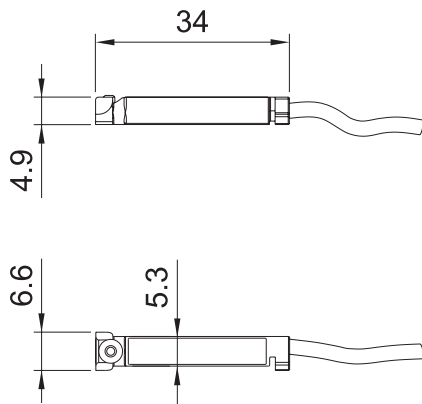

## Dimensioni e schema connettore

Connector layout and dimensions



### RS2-A

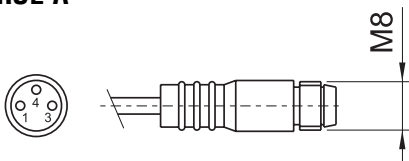

- 1 (marrone - brown) : IN
- 4 (nero - black) : OUT
- 3 (blu - blue) : non utilizzato [unused]

### RS4-A

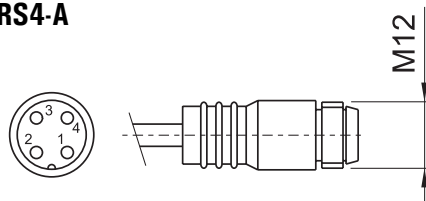

- 1 (marrone - brown) : IN
- 2 (bianco - white) : non utilizzato [unused]
- 3 (blu - blue) : non utilizzato [unused]
- 4 (nero - black) : OUT

### RS7-3F SH2-P

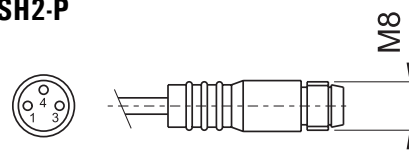

- 1 (marrone - brown) : V+
- 4 (nero - black) : OUT
- 3 (blu - blue) : V-

## PROLUNGHE PER CAVO

Extensions for cable

	lunghezza length	codice di ordinazione order code
<b>M8</b> 3x0.25	3 m	<b>26.164.0</b>
	5 m	<b>26.165.0</b>
<b>M12</b> 3x0.34	3 m	<b>26.166.0</b>
	5 m	<b>26.167.0</b>

# sensori per cilindri

magnetic sensors for cylinders

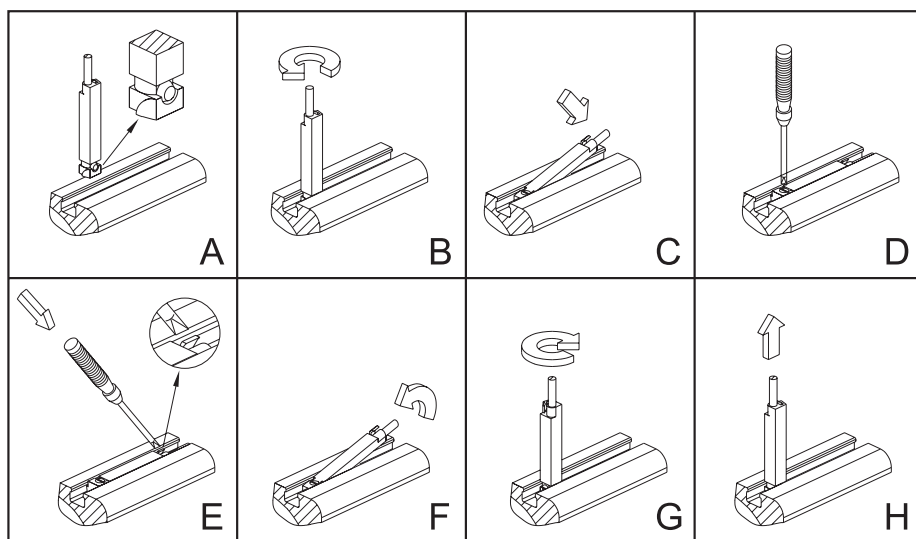

## MONTAGGIO DEI SENSORI SUI CILINDRI ISO 6431

mounting of sensor on cylinders ISO 6431

### Istruzioni per l'installazione:

- A. Inserire dall'alto il sensore come indicato in figura
- B. Ruotare di 90° il corpo del sensore
- C. Alloggiare il sensore nella cava tenendo in vista il taglio del grano
- D. Individuare la posizione di lettura, quindi avvitare il grano

### Istruzioni per la rimozione:

- E. Una volta allentato il grano, agire sul dentino di blocco posteriore
- F. Contemporaneamente sollevare il sensore aiutandosi con il cavo
- G. Ruotare di 90° il corpo del sensore
- H. Estrarre il sensore dalla cava

### Instructions for installation:

- A. Insert the sensor from above as indicated in the image
- B. Rotate the body of the sensor by 90°
- C. Put the sensor in the groove keeping the head of the screw in sight
- D. When the reading position has been found, tighten the screw

### Instructions for removal:

- E. Loosen the screw and apply pressure on the back fixing element
- F. At the same time lift the sensor using the cable for help
- G. Rotate the sensor by 90°
- H. Remove the sensor from the groove



## UTILIZZO DEI SENSORI E STAFFE DI MONTAGGIO

usage of sensors and mounting brackets

CILINDRO	STAFFA [mounting bracket]
microcilindri ISO 6432 minicylinders ISO 6432	ø10 : 26.039.0 ø12 : 26.040.0 ø16 : 26.041.0 ø20 : 26.042.0 ø25 : 26.229.0
cilindri tondi round cylinders	ø32 : 26.230.0 ø40 : 26.231.0 ø50 : 26.232.0
cilindri compatti compact cylinders	su cava a T : montaggio diretto su cava a coda di rondine : 26.147.0
cilindri corsa breve short stroke cylinders	26.147.0
cilindri ISO 6431 ø32 ... 125	montaggio diretto direct mounting
cilindri ISO 6431 ø160-200	26.219.2
cilindri ad asta gemellata twin rod cylinders	montaggio diretto direct mounting

La tabella a lato indica per quali tipi di cilindro si possono utilizzare i sensori di cui alle pagine 364-365, specifica se e quali staffe di montaggio devono essere utilizzate e ne fornisce il codice di ordinazione. Le staffe di montaggio vanno ordinate separatamente.

I nostri sensori possono essere utilizzati anche su cilindri con profilo diverso dal nostro standard. Per le staffe di fissaggio vedi pagina seguente.

*The table shows for which types of cylinder the sensors on pages 364-365 can be used. It indicates also whether a mounting bracket must be used, and gives the order code. Mounting brackets must be ordered separately.*

*Our sensors can be mounted also on cylinders with profile different from our standard. For mounting brackets see the following page.*

### staffa per cilindri ISO 6431 ø160-200

mounting bracket for cylinders ISO 6431 ø160-200

26.219.2

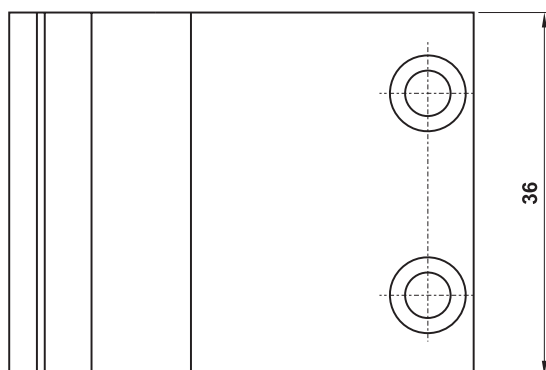
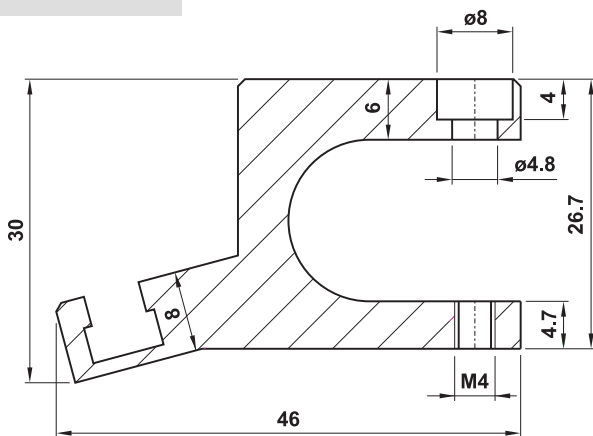

### staffe per microcilindri ISO 6432

mounting brackets for minicylinders ISO 6432

ø10 : 26.039.0

ø12 : 26.040.0

ø16 : 26.041.0

ø20 : 26.042.0

ø25 : 26.229.0

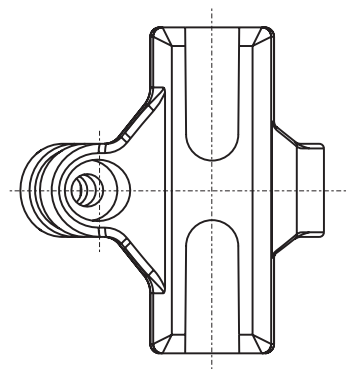
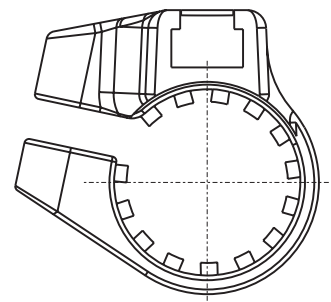

## staffe per cilindri con profilo Mickey Mouse

mounting brackets for cylinders with Mickey Mouse profile

**26.194.0**

ø32 ... 63

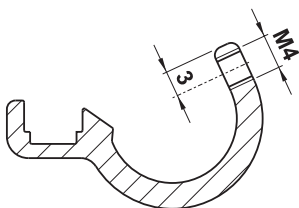
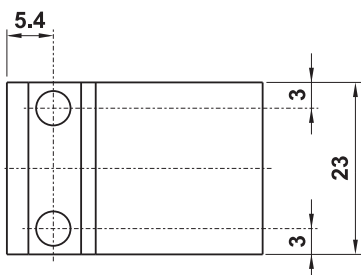
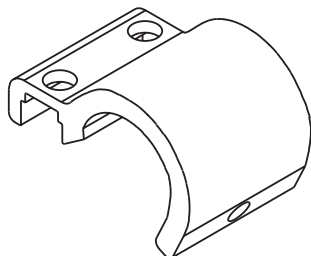

**26.145.0**

ø80-100

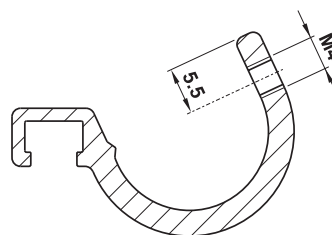
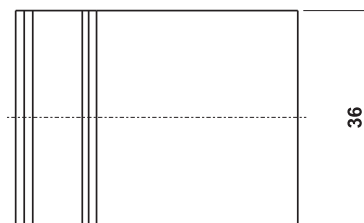
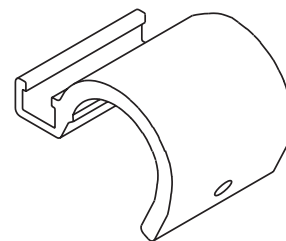

## staffe per cilindri con tubo tondo e tiranti

mounting brackets for cylinders with round profile and tie-rods

**26.195.0**

ø32 ... 63

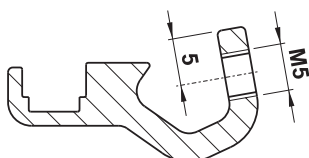
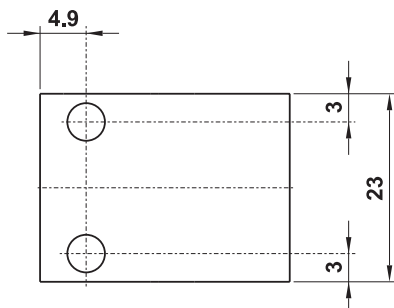
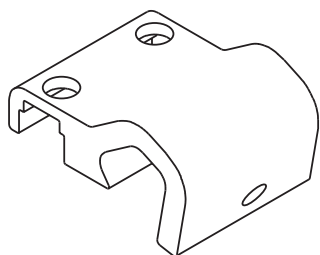

**26.196.0**

ø80-100

