

ART. A580

“EUROMODEL” INDEXED CLAMPING LEVER WITH THREADED INSERT

MATERIAL:

Special high resistance glass fiber reinforced technopolymer.
Oils and greases resistant.

SURFACE:

Satin.

LEVER BODY AND INSERT COLOUR:

Black (RAL 9011).

MAIN INSERT:

Zinc plated steel blind threaded bush.

FIXING SCREW:

Black-oxye treated screw with head for fitting screwdriver.

SPRING:

Zinc plated steel spring.

ALTERNATIVE COLOURS FOR LEVER BODY:

Orange (RAL 2004 cod. 02).

Blue (RAL 5015 cod. 07).

Yellow (RAL 1021 cod.10).

Red (RAL 3000 cod.16).

Green (RAL 6024 cod.17).

Grey (RAL 7035 code 13).

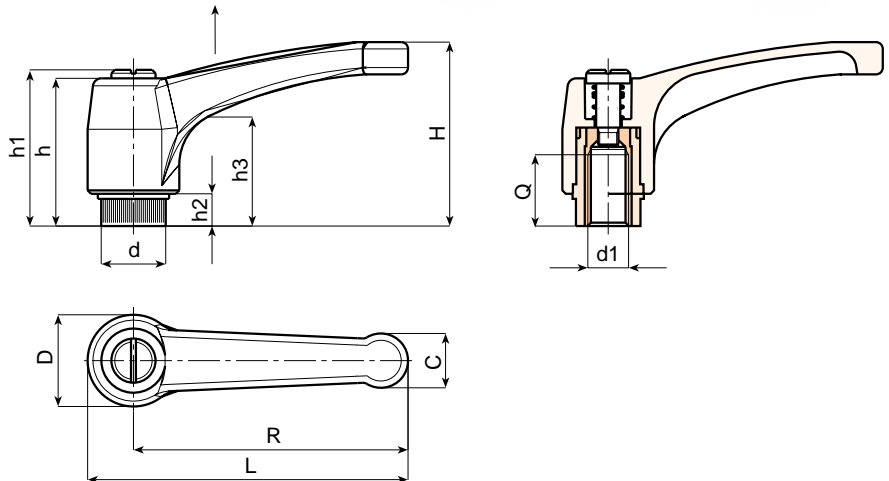

SPECIAL REQUESTS:

- It is possible to supply the inserts in different materials, on request and for quantities.
- It is possible to supply the lever body with colours as shown in the table at page 27, on request and for quantities.

Art.	L	R	H	D	d	c	h	h1	h2	h3	d1	Q	Weight (gr)
A580-43 M04	51	43	33	17	11,5	9	29	32	6	18	M4	8	15
A580-43 M05	51	43	33	17	11,5	9	29	32	6	18	M5	10	15
A580-43 M06	51	43	33	17	11,5	9	29	32	6	18	M6	10	14
A580-52 M06	63	52	41	22	15	12	36	40	8	23	M6	14	31
A580-52 M08	63	52	41	22	15	12	36	40	8	23	M8	14	30
A580-52 M10	63	52	41	22	15	12	36	40	8	23	M10	14	30
A580-65 M06	76	65	43	23	15	13	36	40	8	24	M6	14	36
A580-65 M08	76	65	43	23	15	13	36	40	8	24	M8	14	35
A580-65 M10	76	65	43	23	15	13	36	40	8	24	M10	14	35
A580-80 M08	93	80	54	27	19	15,5	44	48	8,5	29	M8	19	55
A580-80 M10	93	80	54	27	19	15,5	44	48	8,5	29	M10	19	54
A580-80 M12	93	80	54	27	19	15,5	44	48	8,5	29	M12	19	54
A580-94 M08	109	94	56	30	19	18	45	49	9	30	M8	19	80
A580-94 M10	109	94	56	30	19	18	45	49	9	30	M10	19	81
A580-94 M12	109	94	56	30	19	18	45	49	9	30	M12	19	83
+ A580-108 M12	125	108	64	34	24	21	51	55	10	35	M12	-	-
+ A580-108 M14	125	108	64	34	24	21	51	55	10	35	M14	-	-
+ A580-108 M16	125	108	64	34	24	21	51	55	10	35	M16	-	-

+ Available from December 2004

ART. A582

“EUROMODEL” INDEXED CLAMPING LEVER WITH PLASTIC PUSH BUTTON AND THREADED INSERT

MATERIAL:

Special high resistance glass fiber reinforced technopolymer.
Oils and greases resistant.

SURFACE:

Satin.

LEVER BODY AND INSERT COLOUR:

Black (RAL 9011).

MAIN INSERT:

Brass blind threaded bush.

PUSH BUTTON:

Push button in black polyamide (RAL 9011).

SPRING:

Zinc plated steel spring.

ALTERNATIVE COLOURS FOR LEVER BODY AND BUTTON:

Orange (RAL 2004 cod. 02).

Blue (RAL 5015 cod. 07).

Yellow (RAL 1021 cod.10).

Red (RAL 3000 cod.16).

Green (RAL 6024 cod.17).

Grey (RAL 7035 code 13).

SPECIAL REQUESTS:

- It is possible to supply the inserts in different materials, on request and for quantities.
- It is possible to supply the lever body and button with colours as shown in the table at page 27, on request and for quantities.

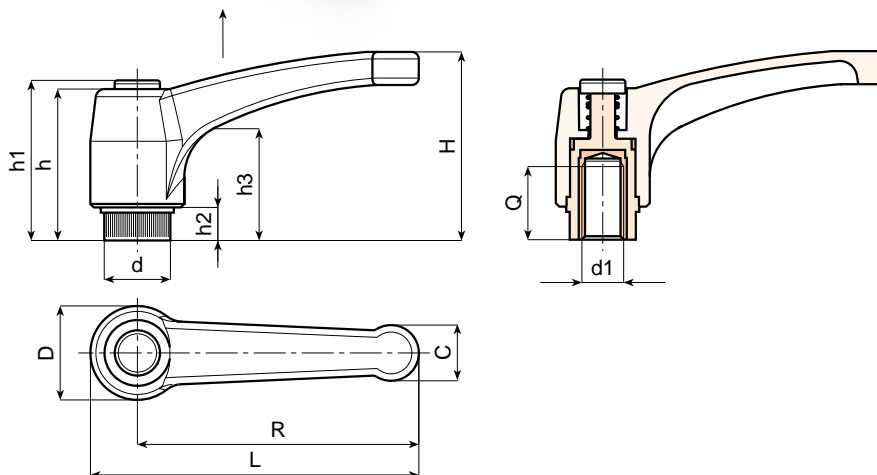

Art.	L	R	H	D	d	c	h	h1	h2	h3	d1	Q	Weight (gr)
A582-43 M04	51	43	33	17	11,5	9	29	32	6	18	M4	8	11
A582-43 M05	51	43	33	17	11,5	9	29	32	6	18	M5	10	11
A582-43 M06	51	43	33	17	11,5	9	29	32	6	18	M6	10	11
A582-52 M06	63	52	41	22	15	12	36	39	8	23	M6	15	20
A582-52 M08	63	52	41	22	15	12	36	39	8	23	M8	15	22
A582-52 M10	63	52	41	22	15	12	36	39	8	23	M10	15	22
A582-65 M06	76	65	43	23	15	13	36	39	8	24	M6	15	24
A582-65 M08	76	65	43	23	15	13	36	39	8	24	M8	15	24
A582-65 M10	76	65	43	23	15	13	36	39	8	24	M10	12	24
A582-80 M08	93	80	54	27	19	15,5	44	47	8,5	29	M08	15	40
A582-80 M10	93	80	54	27	19	15,5	44	47	8,5	29	M10	14	40
A582-80 M12	93	80	54	27	19	15,5	44	47	8,5	29	M12	19	40
A582-94 M08	109	94	56	30	19	18	45	48	9	30	M8	21	75
A582-94 M10	109	94	56	30	19	18	45	48	9	30	M10	19	76
A582-94 M12	109	94	56	30	19	18	45	48	9	30	M12	21	80
+ A582-108 M12	125	108	64	34	24	21	51	55	10	35	M12	-	-
+ A582-108 M14	125	108	64	34	24	21	51	55	10	35	M14	-	-
+ A582-108 M16	125	108	64	34	24	21	51	55	10	35	M16	-	-

+ Available from December 2004

ART. A581

“EUROMODEL” INDEXED CLAMPING LEVER WITH THREADED STUD

MATERIAL:

Special high resistance glass fiber reinforced technopolymer.
Oils and greases resistant.

SURFACE:

Satin.

LEVER BODY AND INSERT COLOUR:

Black (RAL 9011).

MAIN INSERT:

Zinc plated steel threaded stud.

FIXING SCREW:

Black-oxide treated screw with head for fitting screwdriver.

SPRING:

Zinc plated steel spring.

ALTERNATIVE COLOURS FOR LEVER BODY:

Orange (RAL 2004 cod. 02).

Blue (RAL 5015 cod. 07).

Yellow (RAL 1021 cod.10).

Red (RAL 3000 cod.16).

Green (RAL 6024 cod.17).

Grey (RAL 7035 code 13).

SPECIAL REQUESTS:

- It is possible to supply the inserts with different lengths, on request and for quantities.
- It is possible to supply the inserts in different materials, on request and for quantities.
- It is possible to supply the lever body with colours as shown in the table at page 27, on request and for quantities.

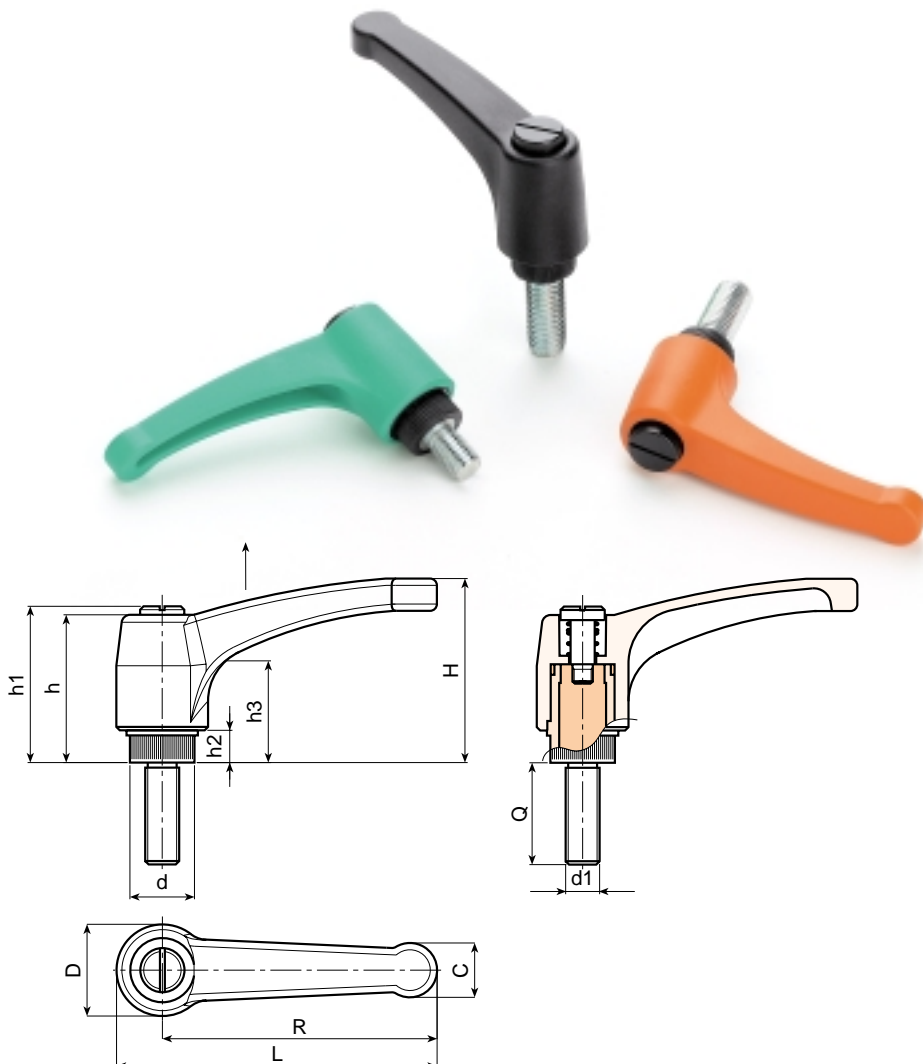

Art.	L	R	H	D	d	c	h	h1	h2	h3	d1	Q	Weight (gr)
A581-43 M04	51	43	33	17	11,5	9	29	32	6	18	M4	10-16-20-25-30-40	18-19-19-20-21-21,5
A581-43 M05	51	43	33	17	11,5	9	29	32	6	18	M5	10-16-20-25-30-40	20-20-21-22-22-23
A581-43 M06	51	43	33	17	11,5	9	29	32	6	18	M6	10-16-20-25-30-40-50	19,5-21-22-23-23,5-25-26,5
A581-52 M06	63	52	41	22	15	12	36	40	8	23	M6	16-20-25-30-35-40-50	38-38-39-40-41-42-43
A581-52 M08	63	52	41	22	15	12	36	40	8	23	M8	16-20-25-30-35-40-45-50	38,5-40-41,5-43-44,5-46-47,5-49
A581-65 M06	76	65	43	23	15	13	36	40	8	24	M6	16-20-25-30-35-40-45-50	40-40-41-42-43-44-44-46
A581-65 M08	76	65	43	23	15	13	36	40	8	24	M8	16-20-25-30-35-40-45-50	41,5-44-45,5-47-48,5-50-51,5-53
A581-80 M08	93	80	54	27	19	15,5	44	48	8,5	29	M8	20-25-30-35-40-45-50	66-67-69-70,5-72-74-76
A581-80 M10	93	80	54	27	19	15,5	44	48	8,5	29	M10	20-25-30-35-40-45-50	74-76,5-79-81,5-84-87
A581-80 M12	93	80	54	27	19	15,5	44	48	8,5	29	M12	20-25-30-35-40-50-60-70-80	89-92-95-99-101-108-115-123-130
A581-94 M08	109	94	56	30	19	18	45	49	9	30	M8	20-25-30-35-40-50	73-74-76-78-79-81
A581-94 M10	109	94	56	30	19	18	45	49	9	30	M10	20-25-30-35-40-45-50-60-70-80	79-80-81-83,5-86-88-91-94-97-100
A581-94 M12	109	94	56	30	19	18	45	49	9	30	M12	20-25-30-35-40-45-50-60-70-80	96-97-99-102-106-108-115-123-130-138
+ A581-108 M12	125	108	64	34	24	21	51	55	10	35	M12	20-30-40-50-60-70	-
+ A581-108 M14	125	108	64	34	24	21	51	55	10	35	M14	30-40-50-60	-
+ A581-108 M16	125	108	64	34	24	21	51	55	10	35	M16	40-50-60	-

+ Available from December 2004

ART. A583

“EUROMODEL” INDEXED CLAMPING LEVER WITH PLASTIC PUSH BUTTON AND THREADED STUD

MATERIAL:

Special high resistance glass fiber reinforced technopolymer.
Oils and greases resistant.

SURFACE:

Satin.

LEVER BODY AND INSERT COLOUR:

Black (RAL 9011).

MAIN INSERT:

Zinc plated steel threaded stud.

PUSH BUTTON:

Push button in black polyamide (RAL 9011).

SPRING:

Zinc plated steel spring.

ALTERNATIVE COLOURS FOR LEVER BODY AND BUTTON:

Orange (RAL 2004 cod. 02).

Blue (RAL 5015 cod. 07).

Yellow (RAL 1021 cod.10).

Red (RAL 3000 cod.16).

Green (RAL 6024 cod.17).

Grey (RAL 7035 code 13).

SPECIAL REQUESTS:

- It is possible to supply the inserts with different lengths, on request and for quantities.
- It is possible to supply the inserts in different materials, on request and for quantities.
- It is possible to supply the lever body and button with colours as shown in the table at page 27, on request and for quantities.

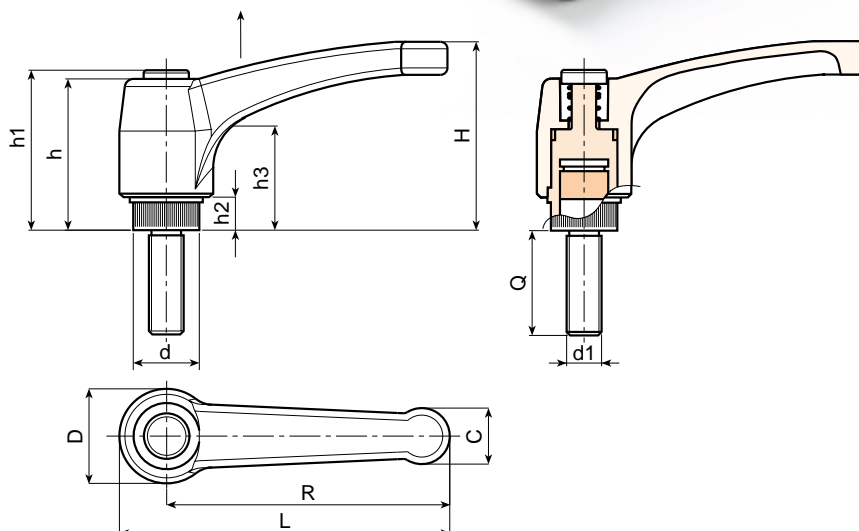

Art.	L	R	H	D	d	c	h	h1	h2	h3	d1	Q	Weight (gr)
A583-43 M04	51	43	33	17	11,5	9	29	32	6	18	M4	10-15-20-25-30-40	9-10-10-11-11-12
A583-43 M05	51	43	33	17	11,5	9	29	32	6	18	M5	10-16-20-25-30-40	12-13-13-14-15-16
A583-43 M06	51	43	33	17	11,5	9	29	32	6	18	M6	10-16-20-25-30-35-40-50	14-15-15,5-16-16,5-18-19,5
A583-52 M06	63	52	41	22	15	12	36	39	8	23	M6	16-20-25-30-35-40-50	22-23-24-25-26-27-28
A583-52 M08	63	52	41	22	15	12	36	39	8	23	M8	16-20-25-30-35-40-45-50	24-25-27-28,5-30-31,5-33-34,5
A583-52 M10	63	52	41	22	15	12	36	39	8	23	M10	20-25-30-35-40-50	31-33,5-36-38,5-41-46
A583-65 M06	76	65	43	23	15	13	36	39	8	24	M6	16-20-25-30-35-40-45-50	26-26-27-27-28-28-29-30
A583-65 M08	76	65	43	23	15	13	36	39	8	24	M8	16-20-25-30-35-40-45-50-60	31,5-33-34,5-36-37,5-39-41-42,5-44
A583-65 M10	76	65	43	23	15	13	36	39	8	24	M10	20-25-30-35-40-45-50	37-39,5-42-44,5-47-49,5-52
A583-80 M08	93	80	54	27	19	15,5	44	47	8,5	29	M8	20-25-30-35-40-50	47-49-50,5-52-54-57
A583-80 M10	93	80	54	27	19	15,5	44	47	8,5	29	M10	20-25-30-35-40-45-50-60-70	54-56,5-59-61,5-64-66,5-69-74-79
A583-80 M12	93	80	54	27	19	15,5	44	47	8,5	29	M12	20-25-30-35-40-45-50-60-70-80	65-69-72-75-79-83-86-93-100-107
A583-94 M08	109	94	56	30	19	18	45	48	9	30	M8	20-25-30-35-40-50	55-57-58-60-62-65
A583-94 M10	109	94	56	30	19	18	45	48	9	30	M10	20-30-35-40-45-50-60-70-80	62-67-69-72-75-77-82-87-92
A583-94 M12	109	94	56	30	19	18	45	48	9	30	M12	20-30-35-40-45-50-60-70-80	73-80-83-87-91-94-101-108-115
+ A583-108 M12	125	108	64	34	24	21	51	55	10	35	M12	20-30-40-50-60-70	-
+ A583-108 M14	125	108	64	34	24	21	51	55	10	35	M14	30-40-50-60	-
+ A583-108 M16	125	108	64	34	24	21	51	55	10	35	M16	40-50-60	-

+ Available from December 2004

ART. A582 CIN

“EUROMODEL” INDEXED CLAMPING LEVER WITH PLASTIC PUSH BUTTON AND STAINLESS STEEL THREADED INSERT

INOX

MATERIAL:

Special high resistance glass fiber reinforced technopolymer.
Oils and greases resistant.

SURFACE:

Satin.

LEVER BODY AND INSERT COLOUR:

Black (RAL 9011).

MAIN INSERT:

Stainless steel blind threaded bush (AISI 303).

PUSH BUTTON:

Push button in black polyamide (RAL 9011).

SPRING:

Stainless steel spring. (AISI 303).

ALTERNATIVE COLOURS FOR LEVER BODY AND BUTTON:

Orange (RAL 2004 cod. 02).

Blue (RAL 5015 cod. 07).

Yellow (RAL 1021 cod.10).

Red (RAL 3000 cod.16).

Green (RAL 6024 cod.17).

Grey (RAL 7035 code 13).

SPECIAL REQUESTS:

- It is possible to supply the lever body and button with colours as shown in the table at page 27, on request and for quantities.

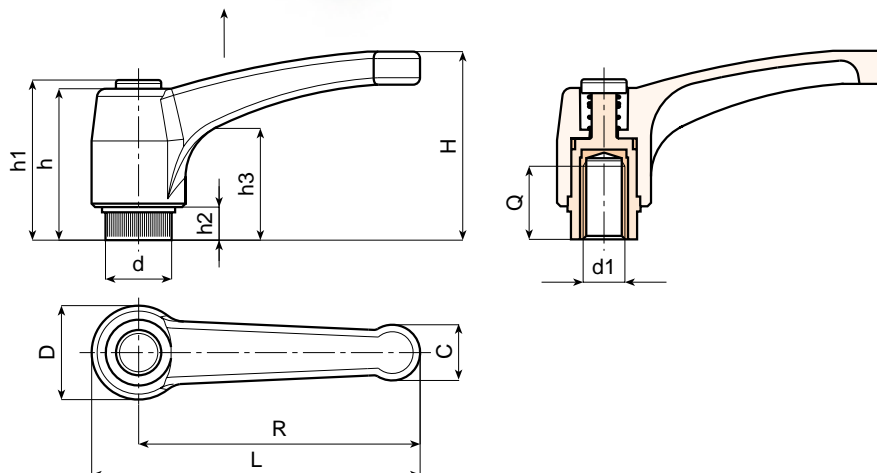

Art.	L	R	H	D	d	c	h	h1	h2	h3	d1	Q	Weight (gr)
A582-43 M04 CIN	51	43	33	17	11,5	9	29	32	6	18	M4	8	13
A582-43 M05 CIN	51	43	33	17	11,5	9	29	32	6	18	M5	10	13
A582-43 M06 CIN	51	43	33	17	11,5	9	29	32	6	18	M6	10	13
A582-52 M06 CIN	63	52	41	22	15	12	36	39	8	23	M6	14	23
A582-52 M08 CIN	63	52	41	22	15	12	36	39	8	23	M8	14	23
A582-52 M10 CIN	63	52	41	22	15	12	36	39	8	23	M10	14	23
A582-65 M06 CIN	76	65	43	23	15	13	36	39	8	24	M6	14	27
A582-65 M08 CIN	76	65	43	23	15	13	36	39	8	24	M8	14	26
A582-65 M10 CIN	76	65	43	23	15	13	36	39	8	24	M10	14	25
A582-80 M08 CIN	93	80	54	27	19	15,5	44	47	8,5	29	M8	15	45
A582-80 M10 CIN	93	80	54	27	19	15,5	44	47	8,5	29	M10	15	43
A582-80 M12 CIN	93	80	54	27	19	15,5	44	47	8,5	29	M12	15	43
A582-94 M08 CIN	109	94	56	30	19	18	45	48	9	30	M08	15	78
A582-94 M10 CIN	109	94	56	30	19	18	45	48	9	30	M10	15	80
A582-94 M12 CIN	109	94	56	30	19	18	45	48	9	30	M12	15	82
+ A582-108 M12 CIN	125	108	65	34	24	21	51	55	10	35	M12	19	-
+ A582-108 M14 CIN	125	108	65	34	24	21	51	55	10	35	M14	19	-
+ A582-108 M16 CIN	125	108	65	34	24	21	51	55	10	35	M16	19	-

+ Available from December 2004

ART. A583 CIN

“EUROMODEL” INDEXED CLAMPING LEVER WITH PLASTIC PUSH BUTTON AND STAINLESS STEEL THREADED STUD

INOX

MATERIAL:

Special high resistance glass fiber reinforced technopolymer.
Oils and greases resistant.

SURFACE:

Satin.

LEVER BODY AND INSERT COLOUR:

Black (RAL 9011).

MAIN INSERT:

Stainless steel threaded stud. (AISI 303).

PUSH BUTTON:

Push button in black polyamide (RAL 9011).

SPRING:

Stainless steel spring. (AISI 303).

ALTERNATIVE COLOURS FOR LEVER BODY AND BUTTON:

Orange (RAL 2004 cod. 02).

Blue (RAL 5015 cod. 07).

Yellow (RAL 1021 cod.10).

Red (RAL 3000 cod.16).

Green (RAL 6024 cod.17).

Grey (RAL 7035 code 13).

SPECIAL REQUESTS:

- It is possible to supply the inserts with different lengths, on request and for quantities.
- It is possible to supply the lever body and button with colours as shown in the table at page 27, on request and for quantities.

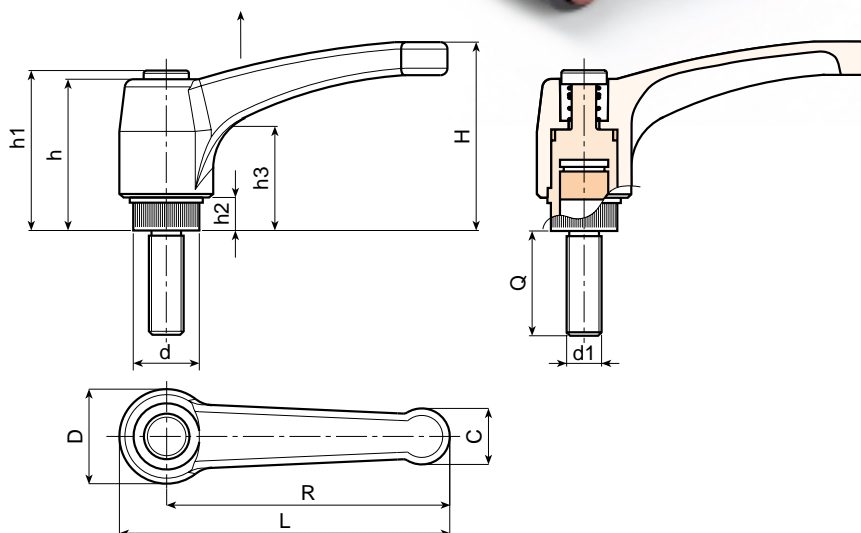

Art.	L	R	H	D	d	c	h	h1	h2	h3	d1	Q	Weight (gr)
A583-43 M04 CIN	51	43	33	17	11,5	9	29	32	6	18	M4	16-20-30	12-13-14
A583-43 M05 CIN	51	43	33	17	11,5	9	29	32	6	18	M5	16-20-30	13-14-15
A583-43 M06 CIN	51	43	33	17	11,5	9	29	32	6	18	M6	16-20-30-40	17-18-20-22
A583-52 M06 CIN	62	52	41	22	15	12	36	39	8	23	M6	16-20-30-40	25-26-28-30
A583-52 M08 CIN	62	52	41	22	15	12	36	39	8	23	M8	16-20-30-40	27-28-31-33
A583-52 M10 CIN	62	52	41	22	15	12	36	39	8	23	M10	16-20-30-40	33-35-40-45
A583-65 M06 CIN	76	65	43	23	15	13	36	39	8	24	M6	16-20-30-40	28-29-31-32,5
A583-65 M08 CIN	76	65	43	23	15	13	36	39	8	24	M8	16-20-30-40	33-35-38-41
A583-65 M10 CIN	76	65	43	23	15	13	36	39	8	24	M10	16-20-30-40	39-41-46-51
A583-80 M08 CIN	93	80	54	27	19	15,5	44	47	8,5	29	M8	16-20-30-40-50	46-49-51-54-57
A583-80 M10 CIN	93	80	54	27	19	15,5	44	47	8,5	29	M10	20-30-40-50	56-61-66-71
A583-80 M12 CIN	93	80	54	27	19	15,5	44	47	8,5	29	M12	20-30-40-50	68-75-82-89
A583-94 M08 CIN	109	94	56	30	19	18	45	48	9	30	M08	20-30-40-50	52-55-58-61
A583-94 M10 CIN	109	94	56	30	19	18	45	48	9	30	M10	20-30-40-50	63-68-73-78
A583-94 M12 CIN	109	94	56	30	19	18	45	48	9	30	M12	20-30-40-50	75-82-89-96
+ A583-108 M12 CIN	125	108	65	34	24	21	51	55	10	35	M12	20-30-40-50	-
+ A583-108 M14 CIN	125	108	65	34	24	21	51	55	10	35	M14	20-30-40-50	-
+ A583-108 M16 CIN	125	108	65	34	24	21	51	55	10	35	M16	20-30-40-50	-

+ Available from December 2004

ART. A522

INDEXED CLAMPING LEVER WITH THREADED INSERT

MATERIAL:

Special high resistance glass fiber reinforced technopolymer.
Oils and greases resistant.

SURFACE:

Satin.

LEVER BODY AND INSERT COLOUR:

Black (RAL 9011).

MAIN INSERT:

Zinc plated steel blind threaded bush.

FIXING SCREW:

Black-oxide treated screw with head for fitting screwdriver.

SPRING:

Zinc plated steel spring.



SPECIAL REQUESTS:

- It is possible to supply the inserts in different materials, on request and for quantities.
- It is possible to supply the lever body with colours as shown in the table at page 27, on request and for quantities.

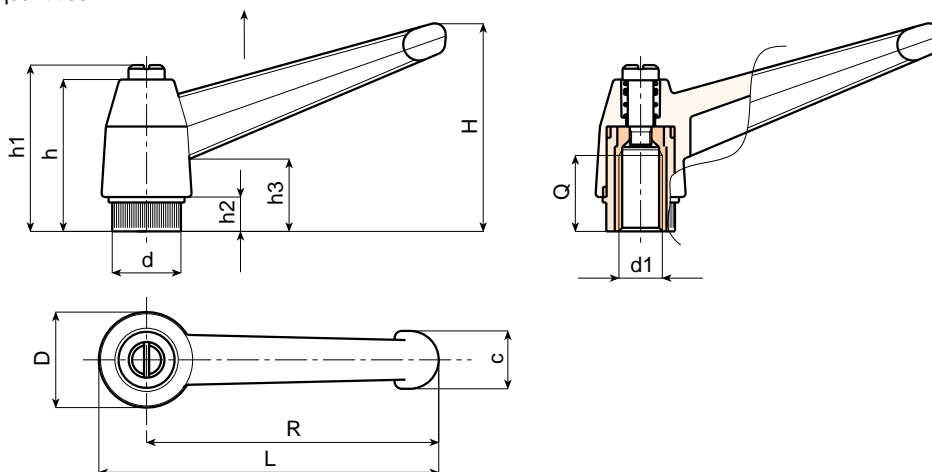

Art.	L	R	H	D	d	c	h	h1	h2	h3	d1	Q	Weight (gr)
A522-43 M04	52	43	33	17	11,5	11	27	30	6	14	M4	10	14
A522-43 M05	52	43	33	17	11,5	11	27	30	6	14	M5	9	14
A522-43 M06	52	43	33	17	11,5	11	27	30	6	14	M6	9	14
A522-65 M06	77	65	45	23	15	13	34	38	8	17	M6	15	28
A522-65 M08	77	65	45	23	15	13	34	38	8	17	M8	15	26
A522-65 M10	77	65	45	23	15	13	34	38	8	17	M10	13	28
A522-83 M08	97	83	57	27	19	16	43	47	10	23	M8	17	52
A522-83 M10	97	83	57	27	19	16	43	47	10	23	M10	17	48
A522-83 M12	97	83	57	27	19	16	43	47	10	23	M12	16	48
A522-104 M10	121	104	70	33	24	19	50	53	11	26	M10	20	114
A522-104 M12	121	104	70	33	24	19	50	53	11	26	M12	22	106
A522-104 M14	121	104	70	33	24	19	50	53	11	26	M14	21	100
A522-104 M16	121	104	70	33	24	19	50	53	11	26	M16	23	100

ART. A523

INDEXED CLAMPING LEVER WITH THREADED STUD

MATERIAL:

Special high resistance glass fiber reinforced technopolymer.
Oils and greases resistant.

SURFACE:

Satin.

LEVER BODY AND INSERT COLOUR:

Black (RAL 9011).

MAIN INSERT:

Zinc plated steel threaded stud.

FIXING SCREW:

Black-oxide treated screw with head for fitting screwdriver.

SPRING:

Zinc plated steel spring.



SPECIAL REQUESTS:

- It is possible to supply the inserts with different lengths, on request and for quantities.
- It is possible to supply the inserts in different materials, on request and for quantities.
- It is possible to supply the lever body with colours as shown in the table at page 27, on request and for quantities.

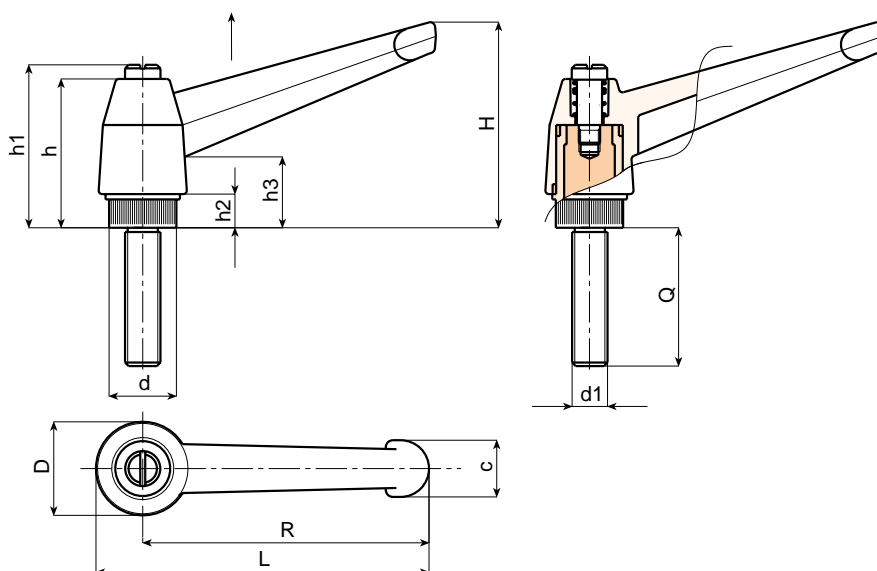

Art.	L	R	H	D	d	c	h	h1	h2	h3	d1	Q	Weight (gr)
A523-43 M04	52	43	33	17	11,5	11	27	30	6	14	M4	10-16-20-25-30-40	16-16-17-18-18-19
A523-43 M05	52	43	33	17	11,5	11	27	30	6	14	M5	10-16-20-25-30-40	16-17-17-17-18-19
A523-43 M06	52	43	33	17	11,5	11	27	30	6	14	M6	10-16-20-25-30-40	18-18-19-20-20-21
A523-65 M06	77	65	45	23	15	13	34	38	8	17	M6	16-20-25-30-40	33-34-35-37
A523-65 M08	77	65	45	23	15	13	34	38	8	17	M8	16-20-25-30-35-40-45-50	35-37-38-40-42-43-44-46
A523-83 M08	97	83	57	27	19	16	43	47	10	23	M8	20-25-30-35-40-50-60	58-59-61-62-64-67-70
A523-83 M10	97	83	57	27	19	16	43	47	10	23	M10	20-25-30-35-40-50-60	67-70-72-74-77-82-87
A523-83 M12	97	83	57	27	19	16	43	47	10	23	M12	20-25-30-35-40-50-60	79-82-86-89-93-100-107
A523-104 M10	121	104	70	33	24	19	50	53	11	26	M10	20-30-40-50-60	109-114-119-124-129
A523-104 M12	121	104	70	33	24	19	50	53	11	26	M12	20-30-40-50-60	115-122-129-136-143
A523-104 M14	121	104	70	33	24	19	50	53	11	26	M14	30-40-50-60-70	140-150-160-170-180
A523-104 M16	121	104	70	33	24	19	50	53	11	26	M16	30-40-50-60-70	156-170-184-198-212

ART. A562

INDEXED CLAMPING LEVER WITH PLASTIC PUSH BUTTON AND THREADED INSERT

MATERIAL:

Special high resistance glass fiber reinforced technopolymer.
Oils and greases resistant.

SURFACE:

Satin.

LEVER BODY AND INSERT COLOUR:

Black (RAL 9011).

MAIN INSERT:

Brass blind threaded bush.

PUSH BUTTON:

Push button in black polyamide (RAL 9011).

SPRING:

Zinc plated steel spring.

ALTERNATIVE COLOURS FOR BUTTON:

Orange (RAL 2004 cod. 02).

Blue (RAL 5015 cod. 07).

Yellow (RAL 1021 cod.10).

Red (RAL 3000 cod.16).

Green (RAL 6024 cod.17).

Grey (RAL 7035 code 13).



SPECIAL REQUESTS:

- It is possible to supply the inserts in different materials, on request and for quantities.
- It is possible to supply the lever body and button with colours as shown in the table at page 27, on request and for quantities.

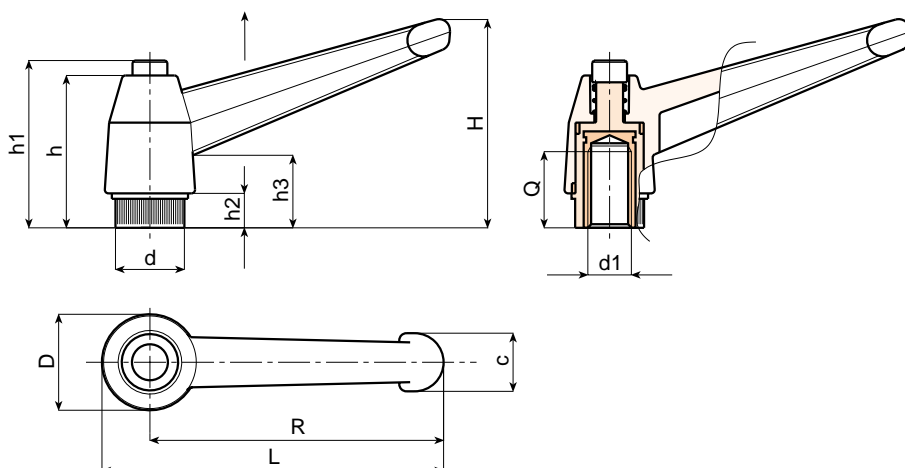

Art.	L	R	H	D	d	c	h	h1	h2	h3	d1	Q	Weight (gr)
A562-43 M04	52	43	33	17	11,5	11	27	32	6	14	M4	8	10
A562-43 M05	52	43	33	17	11,5	11	27	32	6	14	M5	10	10
A562-43 M06	52	43	33	17	11,5	11	27	32	6	14	M6	10	10
A562-65 M06	77	65	45	23	15	13	34	39	8	17	M6	10	20
A562-65 M08	77	65	45	23	15	13	34	39	8	17	M8	15	22
A562-65 M10	77	65	45	23	15	13	34	39	8	17	M10	14	21
A562-83 M08	97	83	57	27	19	16	43	48	9	23	M8	15	36
A562-83 M10	97	83	57	27	19	16	43	48	9	23	M10	14	36
A562-83 M12	97	83	57	27	19	16	43	48	9	23	M12	19	40
A562-104 M10	121	104	70	34	24	19	50	56	11	26	M10	21	68
A562-104 M12	121	104	70	34	24	19	50	56	11	26	M12	19	68
A562-104 M14	121	104	70	34	24	19	50	56	11	26	M14	21	72
A562-104 M16	121	104	70	34	24	19	50	56	11	26	M16	21	76

ART. A563

INDEXED CLAMPING LEVER WITH PLASTIC PUSH BUTTON AND THREADED STUD

MATERIAL:

Special high resistance glass fiber reinforced technopolymer.
Oils and greases resistant.

SURFACE:

Satin.

LEVER BODY AND INSERT COLOUR:

Black (RAL 9011).

MAIN INSERT:

Zinc plated steel threaded stud.

PUSH BUTTON:

Push button in black polyamide (RAL 9011).

SPRING:

Zinc plated steel spring.

ALTERNATIVE COLOURS FOR BUTTON:

Orange (RAL 2004 cod. 02).

Blue (RAL 5015 cod. 07).

Yellow (RAL 1021 cod.10).

Red (RAL 3000 cod.16).

Green (RAL 6024 cod.17).

Grey (RAL 7035 code 13).



SPECIAL REQUESTS:

- It is possible to supply the inserts with different lengths, on request and for quantities.
- It is possible to supply the inserts in different materials, on request and for quantities.
- It is possible to supply the lever body and button with colours as shown in the table at page 27, on request and for quantities.

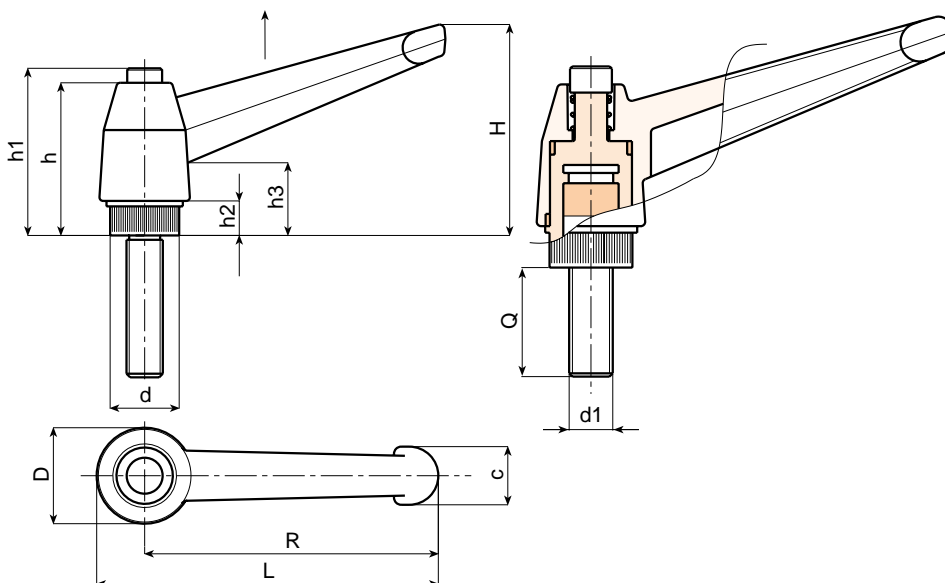

Art.	L	R	H	D	d	c	h	h1	h2	h3	d1	Q	Weight (gr)
A563-43 M04	52	43	33	17	11,5	11	27	32	6	14	M4	10-15-20-25-30-40	8-8-9-9-10-11
A563-43 M05	52	43	33	17	11,5	11	27	32	6	14	M5	10-16-20-25-30-40	11-12-13-13-14-14
A563-43 M06	52	43	33	17	11,5	11	27	32	6	14	M6	10-16-20-25-30-35-40-50	11-12-14-15-16-17-18-20
A563-65 M06	77	65	45	23	15	13	34	39	8	17	M6	16-20-25-30-35-40-45-50	22-23-24-25-26-27-28-29
A563-65 M08	77	65	45	23	15	13	34	39	8	17	M8	16-20-25-30-35-40-45-50	25-26-27-29-30-32-33-35
A563-65 M10	77	65	45	23	15	13	34	39	8	17	M10	20-25-30-35-40-50	31-33-36-39-41-46
A563-83 M08	97	83	57	27	19	16	43	48	9	23	M8	20-25-30-35-40-50-60-70	42-44-45-47-48-51-54-57
A563-83 M10	97	83	57	27	19	16	43	48	9	23	M10	20-25-30-35-40-45-50-60-70	50-53-55-57-60-63-65-70-75
A563-83 M12	97	83	57	27	19	16	43	48	9	23	M12	20-25-30-35-40-50-60-70	62-65-69-72-76-83-90-97
A563-104 M12	121	104	70	34	24	19	50	56	11	26	M12	20-25-30-35-40-50-60-70	84-87-91-96-98-105-112-119
A563-104 M14	121	104	70	34	24	19	50	56	11	26	M14	20-25-30-35-40-50-60-70	90-95-100-105-110-120-130-140
A563-104 M16	121	104	70	34	24	19	50	56	11	26	M16	20-30-40-50-60	108-120-132-146-158

ART. A562 CIN

INDEXED CLAMPING LEVER WITH PLASTIC PUSH BUTTON AND STAINLESS STEEL THREADED INSERT

MATERIAL:

Special high resistance glass fiber reinforced technopolymer.
Oils and greases resistant.

SURFACE:

Satin.

LEVER BODY AND INSERT COLOUR:

Black (RAL 9011).

MAIN INSERT:

Stainless steel blind threaded bush (AISI 303).

PUSH BUTTON:

Push button in black polyamide (RAL 9011).

SPRING:

Stainless steel spring. (AISI 303).

INOX



SPECIAL REQUESTS:

- It is possible to supply the lever body and button with colours as shown in the table at page 27, on request and for quantities.

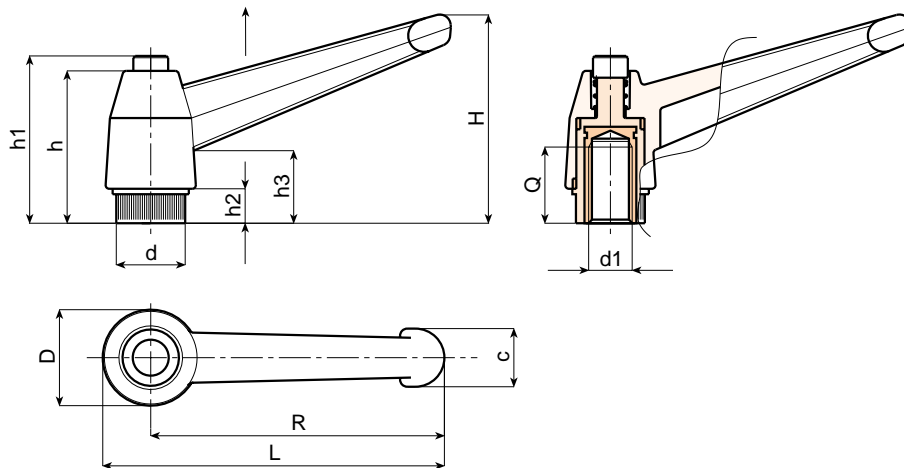

Art.	L	R	H	D	d	c	h	h1	h2	h3	d1	Q	Weight (gr)
A562-43 M04 CIN	52	43	33	17	11,5	11	27	32	6	14	M4	8	13
A562-43 M05 CIN	52	43	33	17	11,5	11	27	32	6	14	M5	10	13
A562-43 M06 CIN	52	43	33	17	11,5	11	27	32	6	14	M6	10	14
A562-65 M06 CIN	77	65	45	23	15	13	34	39	8	17	M6	10	24
A562-65 M08 CIN	77	65	45	23	15	13	34	39	8	17	M8	15	25
A562-65 M10 CIN	77	65	45	23	15	13	34	39	8	17	M10	14	25
A562-83 M08 CIN	97	83	57	27	19	16	43	48	9	23	M8	15	46
A562-83 M10 CIN	97	83	57	27	19	16	43	48	9	23	M10	14	47
A562-83 M12 CIN	97	83	57	27	19	16	43	48	9	23	M12	19	48
A562-104 M10 CIN	121	104	70	34	24	19	50	56	11	26	M10	21	72
A562-104 M12 CIN	121	104	70	34	24	19	50	56	11	26	M12	19	76
A562-104 M14 CIN	121	104	70	34	24	19	50	56	11	26	M14	21	77
A562-104 M16 CIN	121	104	70	34	24	19	50	56	11	26	M16	21	77

ART. A563 CIN

INDEXED CLAMPING LEVER WITH PLASTIC PUSH BUTTON AND STAINLESS STEEL THREADED STUD

MATERIAL:

Special high resistance glass fiber reinforced technopolymer.
Oils and greases resistant.

SURFACE:

Satin.

LEVER BODY AND INSERT COLOUR:

Black (RAL 9011).

MAIN INSERT:

Stainless steel threaded stud. (AISI 303).

PUSH BUTTON:

Push button in black polyamide (RAL 9011).

SPRING:

Stainless steel spring. (AISI 303).

INOX



SPECIAL REQUESTS:

- It is possible to supply the inserts with different lengths, on request and for quantities.
- It is possible to supply the lever body and button with colours as shown in the table at page 27, on request and for quantities.

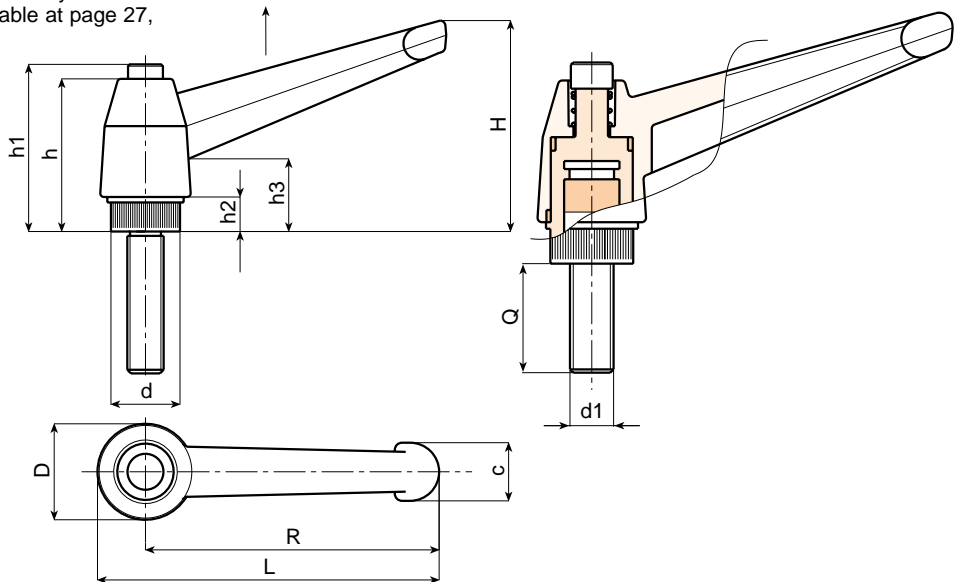

Art.	L	R	H	D	d	c	h	h1	h2	h3	d1	Q	Weight (gr)
A563-43 M04 CIN	52	43	33	17	11,5	11	27	32	6	14	M4	16-20-30	10-11-12
A563-43 M05 CIN	52	43	33	17	11,5	11	27	32	6	14	M5	16-20-30	14-15-16
A563-43 M06 CIN	52	43	33	17	11,5	11	27	32	6	14	M6	16-20-30	15-16-18
A563-65 M06 CIN	77	65	45	23	15	13	34	39	8	17	M6	16-20-30-40	24-25-27-29
A563-65 M08 CIN	77	65	45	23	15	13	34	39	8	17	M8	16-20-30-40	27-28-31-34
A563-65 M10 CIN	77	65	45	23	15	13	34	39	8	17	M10	16-20-30-40	30-33-38-43
A563-83 M08 CIN	97	83	57	27	19	16	43	48	9	23	M8	20-30-40-50	44-47-50-53
A563-83 M10 CIN	97	83	57	27	19	16	43	48	9	23	M10	20-30-40-50	52-57-62-67
A563-83 M12 CIN	97	83	57	27	19	16	43	48	9	23	M12	20-30-40-50	61-64-71-78
A563-104 M12 CIN	121	104	70	34	24	19	50	56	11	26	M12	20-30-40-50	86-93-101-108
A563-104 M14 CIN	121	104	70	34	24	19	50	56	11	26	M14	20-30-40-50	92-102-112-122
A563-104 M16 CIN	121	104	70	34	24	19	50	56	11	26	M16	20-30-40-50	111-122-134-146

ART. A592

ZAMAK ALLOY INDEXED CLAMPING LEVER WITH THREADED INSERT

MATERIAL:

Die cast Zamak lever body
(zinc,aluminium, copper alloy).

SURFACE:

Smooth. Epoxy powder painted finish.

COLOURS:

Shiny black (RAL 9005).
Matt black (RAL 9005).
Orange (RAL 2004).
Red (RAL 3000).
Metalized grey (RAL 9006).
Grey (RAL 7031).
Blue (RAL 5015).

MAIN INSERT:

Black oxide treated steel insert
with female threaded hole.

FIXING SCREW:

Black-oxide treated screw
with hexagon socket head.

SPRING:

Zinc plated steel spring.

SPECIAL REQUESTS:

- None.

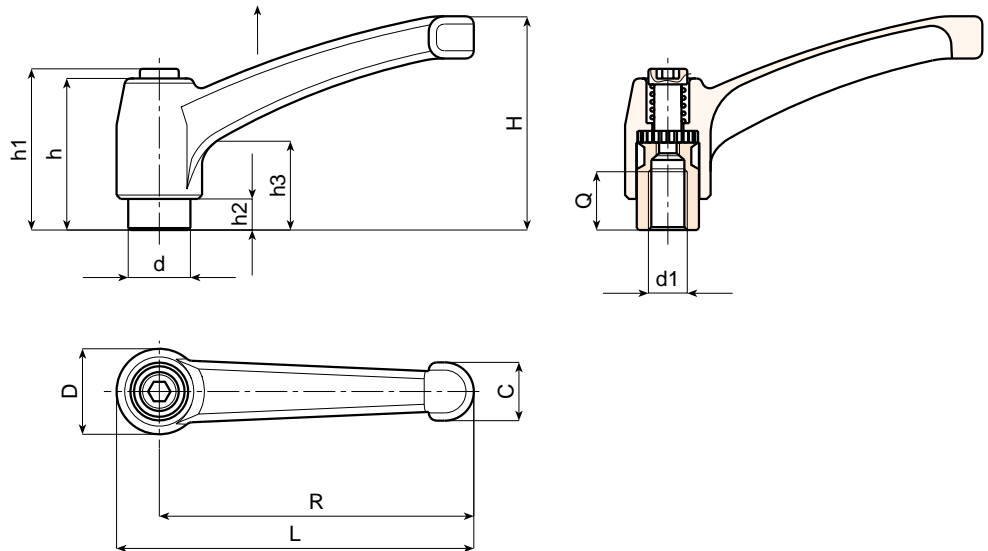

Art.	L	R	H	D	d	c	h	h1	h2	h3	d1	Q	Weight (gr)
A592-43 M04	50	43	30	14	10	9	26	30	5	14	M4	7	30
A592-43 M05	50	43	30	14	10	9	26	30	5	14	M5	9	30
A592-43 M06	50	43	30	14	10	9	26	30	5	14	M6	9	28
A592-65 M06	75	65	45	19	14	13	32	34	7	14	M6	10	76
A592-65 M08	75	65	45	19	14	13	32	34	7	14	M8	10	76
A592-65 M10	75	65	45	19	14	13	32	34	7	14	M10	9	73
A592-80 M08	91	80	57	22	16	16	40	42	8	16	M8	14	134
A592-80 M10	91	80	57	22	16	16	40	42	8	16	M10	13	130
A592-80 M12	91	80	57	22	16	16	40	42	8	16	M12	12	128
A592-94 M12	107	94	65	26	20	18	47	50	10,5	19	M12	20	195
A592-94 M14	107	94	65	26	20	18	47	50	10,5	19	M14	20	190
A592-94 M16	107	94	65	26	20	18	47	50	10,5	19	M16	20	188
A592-108 M14	123	108	75	30	23	20	54	56	12	23	M14	26	298
A592-108 M16	123	108	75	30	23	20	54	56	12	23	M16	26	284
A592-108 M18	123	108	75	30	23	20	54	56	12	23	M18	25	270

ART. A593

ZAMAK ALLOY INDEXED CLAMPING LEVER WITH THREADED STUD

MATERIAL:

Die cast Zamak lever body
(zinc, aluminium, copper alloy).

SURFACE:

Smooth. Epoxy powder painted finish.

COLOURS:

Shiny black (RAL 9005).
Matt black (RAL 9005).
Orange (RAL 2004).
Red (RAL 3000).
Metalized grey (RAL 9006).
Grey (RAL 7031).
Blue (RAL 5015).

MAIN INSERT:

Black oxide treated steel insert
with male threaded stud.

FIXING SCREW:

Black-oxide treated screw
with hexagon socket head.

SPRING:

Zinc plated steel spring.

SPECIAL REQUESTS:

- It is possible to supply the inserts with different lengths, on request and for quantities.

Attention: for out of standard lengths, insert with threaded stud will be zinc plated.

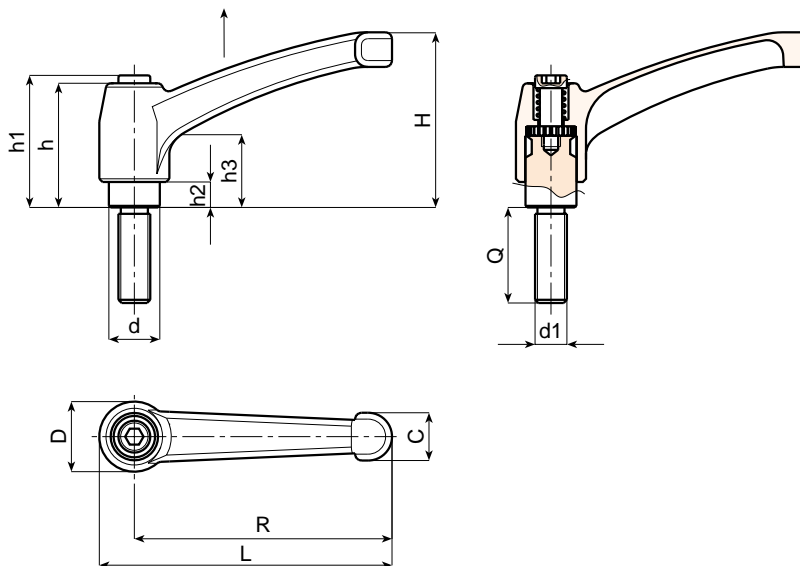

Art.	L	R	H	D	d	c	h	h1	h2	h3	d1	Q	Weight (gr)
A593-43 M04	50	43	30	14	10	9	26	30	5	14	M4	16-20-25-30	30-30-31-31
A593-43 M05	50	43	30	14	10	9	26	30	5	14	M5	16-20-25-30-40	31-32-33-34-35
A593-43 M06	50	43	30	14	10	9	26	30	5	14	M6	16-20-25-30-40-50	31-32-33-34-35-36
A593-43 M08	50	43	30	14	10	9	26	30	5	14	M8	25-40-50	38-43-46
A593-65 M06	75	65	45	19	14	13	32	34	7	14	M6	16-20-25-30-40-50	79-82-83-84-86-88
A593-65 M08	75	65	45	19	14	13	32	34	7	14	M8	16-20-25-30-35-40-45-50-60	82-83-84-86-88-89-90-92-95
A593-65 M10	75	65	45	19	14	13	32	34	7	14	M10	20-25-30-35-40-45-50-60	89-91-94-97-99-101-104-109
A593-80 M08	91	80	57	22	16	16	40	42	8	16	M8	20-25-30-35-40-45-50-60	142-144-145-147-148-150-151-154
A593-80 M10	91	80	57	22	16	16	40	42	8	16	M10	20-25-30-35-40-45-50-60	146-148-151-153-156-159-161-166
A593-80 M12	91	80	57	22	16	16	40	42	8	16	M12	20-25-30-35-40-50-60	150-154w-157-160-164-171-178
A593-94 M12	107	94	65	26	20	17,5	47	50	10,5	19	M12	20-25-30-35-40-50-60	229-232-236-240-243-250-257
A593-94 M14	107	94	65	26	20	17,5	47	50	10,5	19	M14	30-35-40-50-60	240-245-250-260-270
A593-94 M16	107	94	65	26	20	17,5	47	50	10,5	19	M16	30-40-50-60	254-266-278-290
A593-108 M12	123	108	75	30	23	20	54	56	12	23	M12	25-50	330-347
A593-108 M14	123	108	75	30	23	20	54	56	12	23	M14	20-30-40-50-60	340-350-360-370-380
A593-108 M16	123	108	75	30	23	20	54	56	12	23	M16	20-30-40-50-60	328-342-356-370-384
A593-108 M18	123	108	75	30	23	20	54	56	12	23	M18	20-30-40-50-60	360-380-400-420

ART. A572

INDEXED CLAMPING LEVER WITH ARM AT 90° AND THREADED INSERT

MATERIAL:

Special high resistance glass fiber reinforced technopolymer.
Oils and greases resistant.

SURFACE:

Satin.

LEVER BODY AND INSERT COLOUR:

Black (RAL 9011).

MAIN INSERT:

Zinc plated steel blind threaded bush.

FIXING SCREW:

Black-oxide treated screw with head for fitting screwdriver.

SPRING:

Zinc plated steel spring.



SPECIAL REQUESTS:

- It is possible to supply the inserts in different materials, on request and for quantities.
- It is possible to supply the lever body with colours as shown in the table at page 27, on request and for quantities.

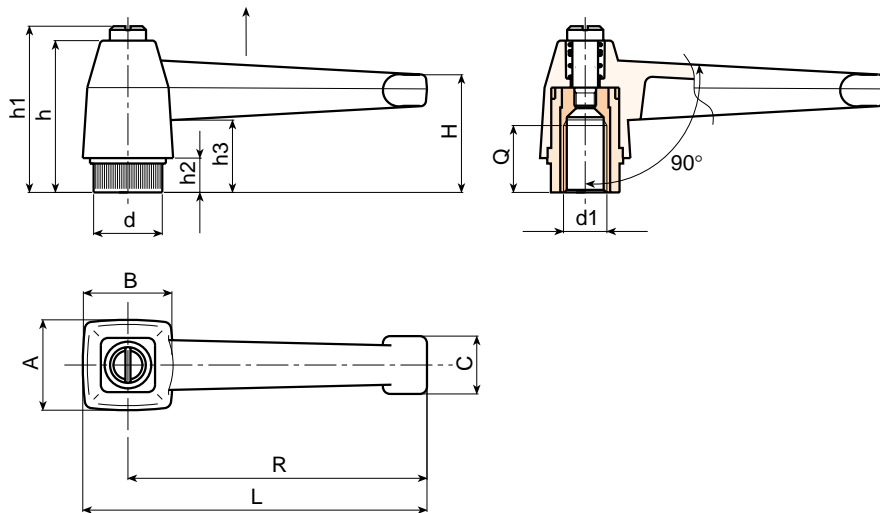

Art.	L	R	H	A	B	c	h	h1	h2	h3	d1	Q	Weight (gr)
A572-83 M08	94	83	33,5	25	25	16	42	47	10	21	M8	17	52
A572-83 M10	94	83	33,5	25	25	16	42	47	10	21	M10	17	48
A572-83 M12	94	83	33,5	25	25	16	42	47	10	21	M12	16	48

ART. A573

INDEXED CLAMPING LEVER WITH ARM AT 90° AND THREADED STUD

MATERIAL:

Special high resistance glass fiber reinforced technopolymer.
Oils and greases resistant.

SURFACE:

Satin.

LEVER BODY AND INSERT COLOUR:

Black (RAL 9011).

MAIN INSERT:

Zinc plated steel threaded stud.

FIXING SCREW:

Black-oxide treated screw with head for fitting screwdriver.

SPRING:

Zinc plated steel spring.



SPECIAL REQUESTS:

- It is possible to supply the inserts with different lengths, on request and for quantities.
- It is possible to supply the inserts in different materials, on request and for quantities.
- It is possible to supply the lever body with colours as shown in the table at page 27, on request and for quantities.

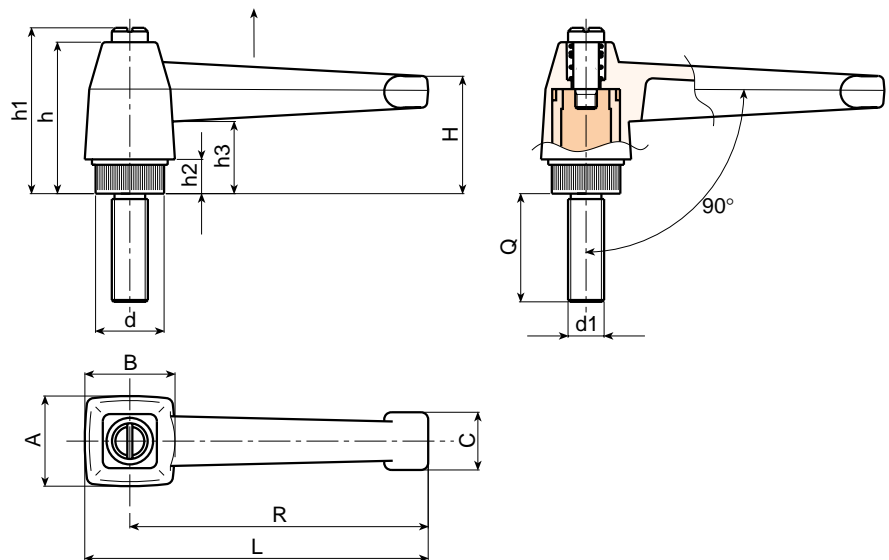

Art.	L	R	H	A	B	c	h	h1	h2	h3	d1	Q	Weight (gr)
A573-83 M08	94	83	33,5	25	25	16	42	47	10	21	M8	20-30-40-50	58-60-64-66
A573-83 M10	94	83	33,5	25	25	16	42	47	10	21	M10	20-30-40-50	68-72-76-80
A573-83 M12	94	83	33,5	25	25	16	42	47	10	21	M12	30-40-50	87-94-100-

ART. A150

“EUROMODEL” FIXED LEVER WITH THREADED INSERT

**PROTECTED
MODEL**

MATERIAL:

Special high resistance glass fiber reinforced technopolymer.
Oils and greases resistant.

SURFACE:

Satin.

COLOUR:

Black (RAL 9011).

CENTRAL CAP:

Grey polyamide (RAL 7035 code 13).

MAIN INSERT:

Zinc plated steel right through threaded bush.

ALTERNATIVE CAP COLOUR:

Orange (RAL 2004 cod. 02).

Blue (RAL 5015 cod. 07).

Yellow (RAL 1021 cod.10).

Red (RAL 3000 cod.16).

Green (RAL 6024 cod.17).

Black (RAL 9011 cod. 01).



SPECIAL REQUESTS:

- Fixing springs and balls (zinc plated steel) available upon request.
- It is possible to supply the inserts in different materials, on request and for quantities.
- It is possible to supply the inserts with different treatment-finishes, on request and for quantities.
- It is possible to supply the push fit central cap with colours as shown in the table at page 27, on request.
- It is possible to supply colours as shown in the table at page 27, on request and for quantities.

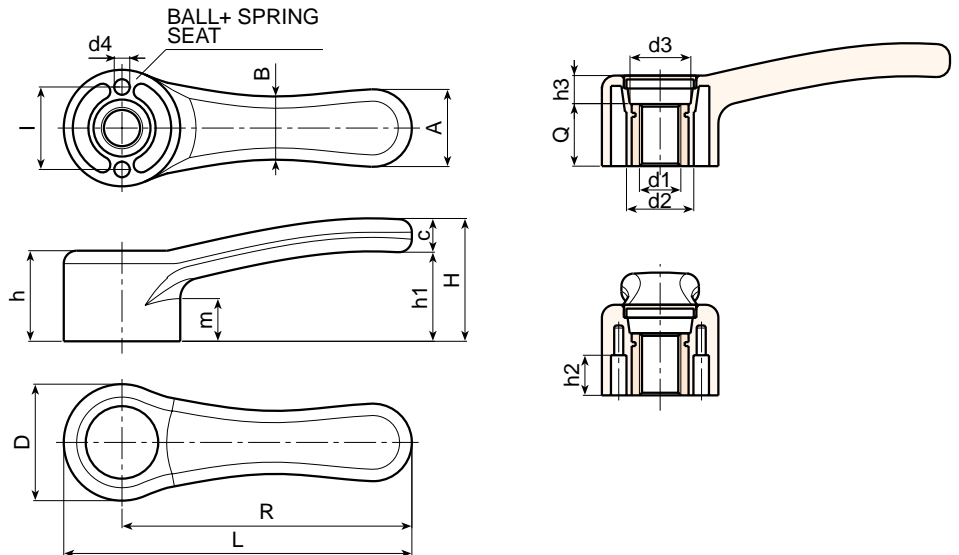

Art.	R	L	D	H	h	h1	h2	h3	m	A	B	c	d1	d2	d3	d4	d1	Q	Weight (gr)
A150-68 M06	68	84,5	33	37	25	27	12	9	12	20	17	10	5	20	16	4	M6	16	42
A150-68 M08	68	84,5	33	37	25	27	12	9	12	20	17	10	5	20	16	4	M8	16	40
A150-68 M10	68	84,5	33	37	25	27	12	9	12	20	17	10	5	20	16	4	M10	16	40
A150-86 M08	86	104	36	40	28	29	12	12	13	24	19	11	5	22	18	5	M8	16	72
A150-86 M10	86	104	36	40	28	29	12	12	13	24	19	11	5	22	18	5	M10	16	71
A150-86 M12	86	104	36	40	28	29	12	12	13	24	19	11	5	22	18	5	M12	16	70
A150-112 M12	112	134,5	45	47	36	35	15	12	16	30	24	13	5	26	23,5	6	M12	24	99
A150-112 M14	112	134,5	45	47	36	35	15	12	16	30	24	13	5	26	23,5	6	M14	24	98
A150-112 M16	112	134,5	45	47	36	35	15	12	16	30	24	13	5	26	23,5	6	M16	24	95
A150-142 M14	142	169,5	55	52	40	36	19	13	17,5	37	30	16	5	32	28	8	M14	27	240
A150-142 M16	142	169,5	55	52	40	36	19	13	17,5	37	30	16	5	32	28	8	M16	27	235
A150-142 M18	142	169,5	55	52	40	36	19	13	17,5	37	30	16	5	32	28	8	M18	27	230

ART. A151

“EUROMODEL” FIXED LEVER WITH SMOOTH INSERT

**PROTECTED
MODEL**

MATERIAL:

Special high resistance glass fiber reinforced technopolymer.
Oils and greases resistant.

SURFACE:

Satin.

COLOUR:

Black (RAL 9011).

CENTRAL CAP:

Grey polyamide (RAL 7035 code 13).

MAIN INSERT:

Zinc plated steel right through bored bush with H7 tolerance.

ALTERNATIVE CAP COLOUR:

Orange (RAL 2004 cod. 02).

Blue (RAL 5015 cod. 07).

Yellow (RAL 1021 cod.10).

Red (RAL 3000 cod.16).

Green (RAL 6024 cod.17).

Black (RAL 9011 cod. 01).

SPECIAL REQUESTS:

- Fixing springs and balls (zinc plated steel) available upon request.
- It is possible to supply the inserts with d1 diameter by customer design, on request and for quantities.
- It is possible to supply the inserts in different materials, on request and for quantities.
- It is possible to supply the inserts with different treatment-finishes, on request and for quantities.
- It is possible to supply the push fit central cap with colours as shown in the table at page 27, on request.
- It is possible to supply colours as shown in the table at page 27, on request and for quantities.

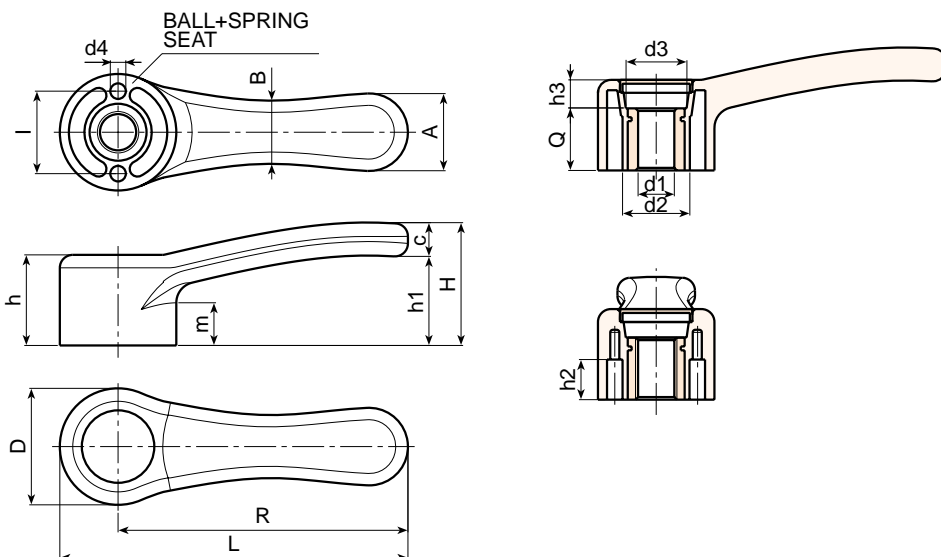

Art.	R	L	D	H	h	h1	h2	h3	m	A	B	c	d1	d2	d3	d4	dm	d1 H7	Q	Weight (gr)
A151-68 D05	68	84,5	33	37	25	27	12	9	12	20	17	10	5	20	16	4	10	D05	16	45
A151-68 D10	68	84,5	33	37	25	27	12	9	12	20	17	10	5	20	16	4	10	D10	16	44
A151-86 D05	86	104	36	40	28	29	12	12	13	24	19	11	5	22	18	5	12	D05	16	65
A151-86 D10	86	104	36	40	28	29	12	12	13	24	19	11	5	22	18	5	12	D10	16	61
A151-112 D05	112	134,5	45	47	36	35	15	12	16	30	24	13	5	26	23,5	6	16	D05	24	128
A151-112 D12	112	134,5	45	47	36	35	15	12	16	30	24	13	5	26	23,5	6	16	D12	24	124
A151-142 D05	142	169,5	55	52	40	36	19	13	17,5	37	30	16	5	32	28	8	20	D05	27	250
A151-142 D14	142	169,5	55	52	40	36	19	13	17,5	37	30	16	5	32	28	8	20	D14	27	240

It's possible to increase the hole, by boring, until **dm**.

ART. A528

FIXED LEVER WITH THREADED INSERT

MATERIAL:

Reinforced polyamide.
Oils and greases resistant.

SURFACE:

Satin.

COLOUR:

Black (RAL 9011).

MAIN INSERT:

Brass blind threaded bush.

SPECIAL REQUESTS:

- It is possible to supply the inserts in different materials, on request and for quantities.
- It is possible to supply colours as shown in the table at page 27, on request and for quantities.

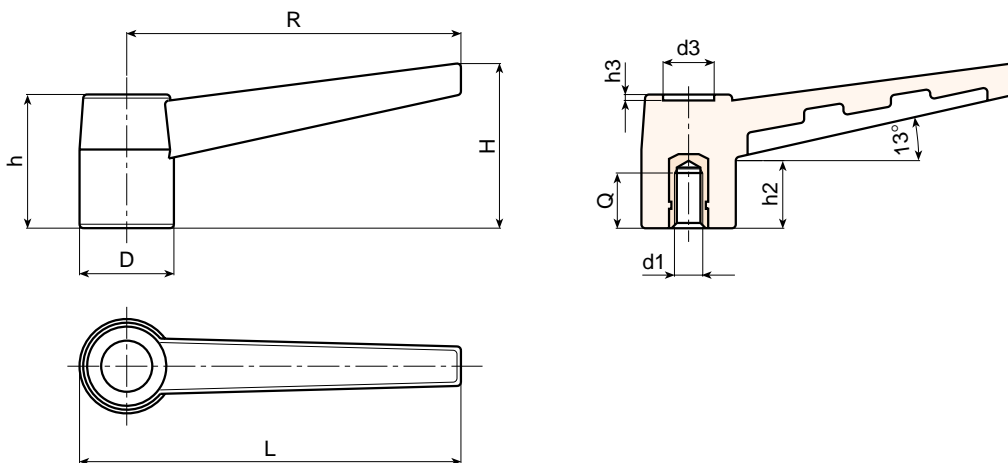

Art.	L	R	H	D	h	h2	h3	d3	d1	Q	Weight (gr)
A528-43 M05	50	43	21,5	15	19	9	1	7	M5	10	8
A528-43 M06	50	43	21,5	15	19	9	1	7	M6	10	8
A528-68 M06	78	68	36	21	28,5	11	2	10	M6	10	24
A528-68 M08	78	68	36	21	28,5	11	2	10	M8	15	22
A528-83 M06	93	83	40	24	34	18	2	13	M6	10	30
A528-83 M08	93	83	40	24	34	18	2	13	M8	15	32
A528-83 M10	93	83	40	24	34	18	2	13	M10	14	32

ART. A529

FIXED LEVER WITH THREADED STUD

MATERIAL:

Reinforced polyamide.
Oils and greases resistant.

SURFACE:

Satin.

COLOUR:

Black (RAL 9011).

MAIN INSERT:

Zinc plated steel threaded stud.

SPECIAL REQUESTS:

- It is possible to supply the inserts with different lengths, on request and for quantities.
- It is possible to supply the inserts in different materials, on request and for quantities.
- It is possible to supply colours as shown in the table at page 27, on request and for quantities.

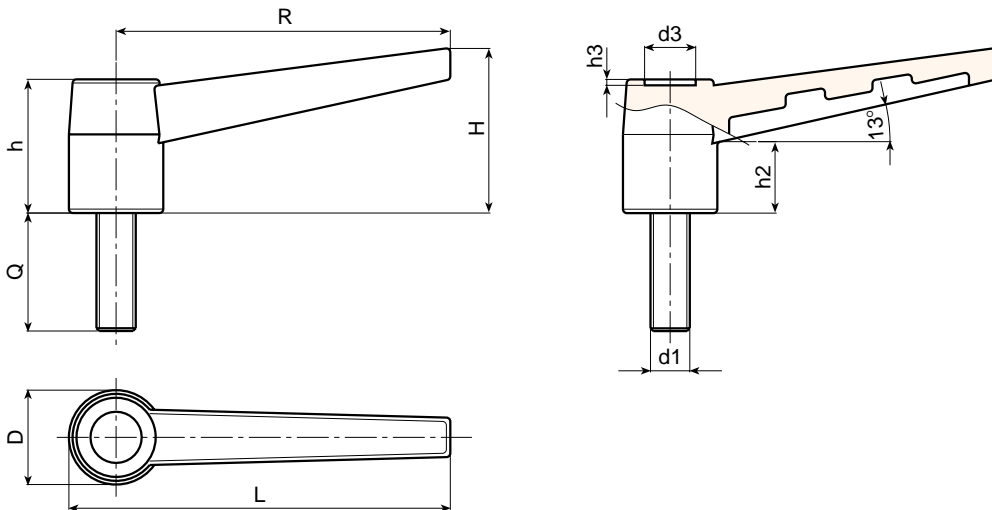

Art.	L	R	H	D	h	h2	h3	d3	d1	Q	Weight (gr)
A529-43 M05	50	43	21,5	15	19	9	1	7	M5	10-20-30	9-10-11
A529-43 M06	50	43	21,5	15	19	9	1	7	M6	10-20-30-40	10-12-14-16
A529-68 M06	78	68	36	21	28,5	11	2	10	M6	10-20-30-40	25-27-29-31
A529-68 M08	78	68	36	21	28,5	11	2	10	M8	16-20-30-40	30-32-36-39
A529-83 M06	93	83	40	24	34	18	2	13	M6	20-30	41-43
A529-83 M08	93	83	40	24	34	18	2	13	M8	20-30-40-50-60	44-47-50-53-56
A529-83 M10	93	83	40	24	34	18	2	13	M10	20-30-40	48-53-58

ART. A524

FIXED LEVER WITH THREADED INSERT

MATERIAL:

Reinforced polyamide.
Oils and greases resistant.

SURFACE:

Satin.

COLOUR:

Black (RAL 9011).

MAIN INSERT:

Brass blind threaded bush.
(*) Zinc plated steel blind threaded bush.

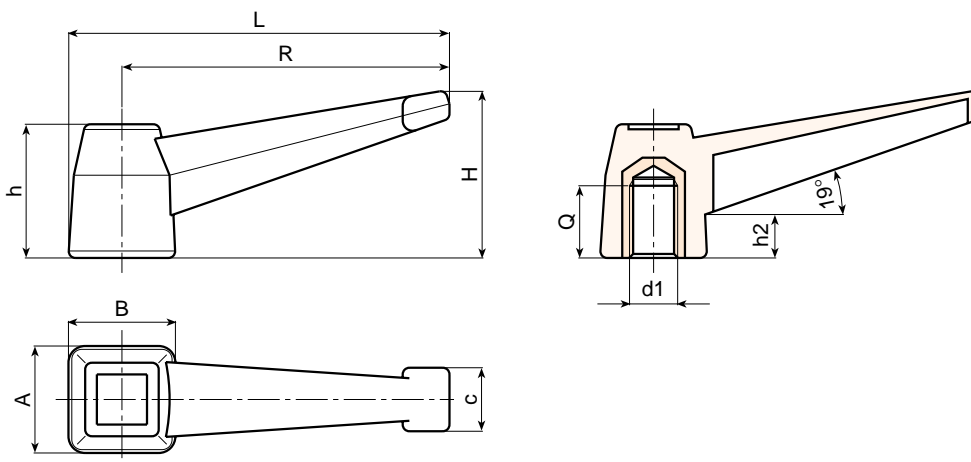

Art.	L	R	H	A	B	c	h	h2	d1	Q	Weight (gr)
A524-98 M12	112	96	51	32	32	19	40	12	M12	19	64
A524-98 M14	112	96	51	32	32	19	40	12	M14	19	68
A524-98 M16	112	96	51	32	32	19	40	12	(*) M16	16	80

ART. A525

FIXED LEVER WITH THREADED STUD

MATERIAL:

Reinforced polyamide.
Oils and greases resistant.

SURFACE:

Satin.

COLOUR:

Black (RAL 9011).

MAIN INSERT:

Zinc plated steel threaded stud.

SPECIAL REQUESTS:

- It is possible to supply the inserts with different lengths, on request and for quantities.
- It is possible to supply the inserts in different materials, on request and for quantities.

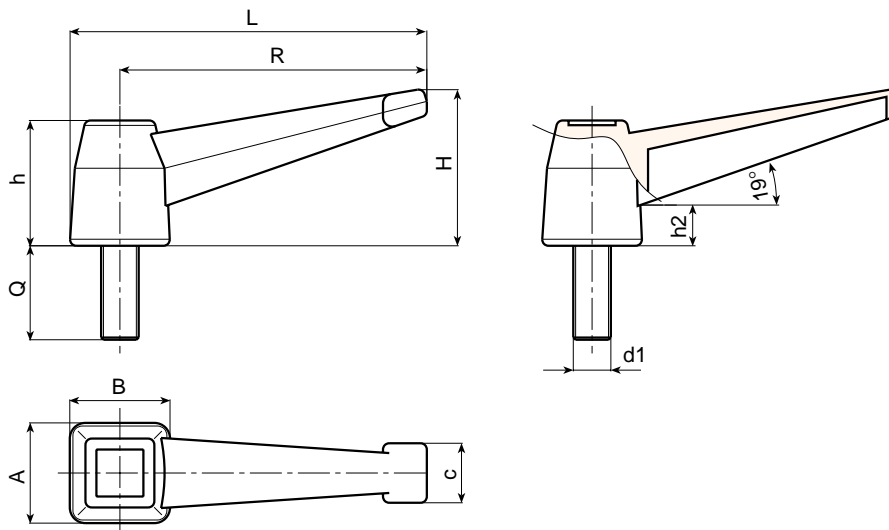

Art.	L	R	H	A	B	c	h	h2	d1	Q	Weight (gr)
A525-98 M10	112	96	51	32	32	19	40	12	M10	40	95
A525-98 M12	112	96	51	32	32	19	40	12	M12	20-40	99-113
A525-98 M14	112	96	51	32	32	19	40	12	M14	20-25-40	105-125
A525-98 M16	112	96	51	32	32	19	40	12	M16	30-40	127-141

ART. A148

LOCKING HANDLE WITH THREADED INSERT

MATERIAL:

Reinforced polyamide.
Oils and greases resistant.

SURFACE:

Satin.

COLOUR:

Black (RAL 9011).

CENTRAL CAP:

Grey polyamide (RAL 7035 code 13).

MAIN INSERT:

Brass blind threaded bush.



SPECIAL REQUESTS:

- It is possible to supply the inserts in different materials, on request and for quantities.

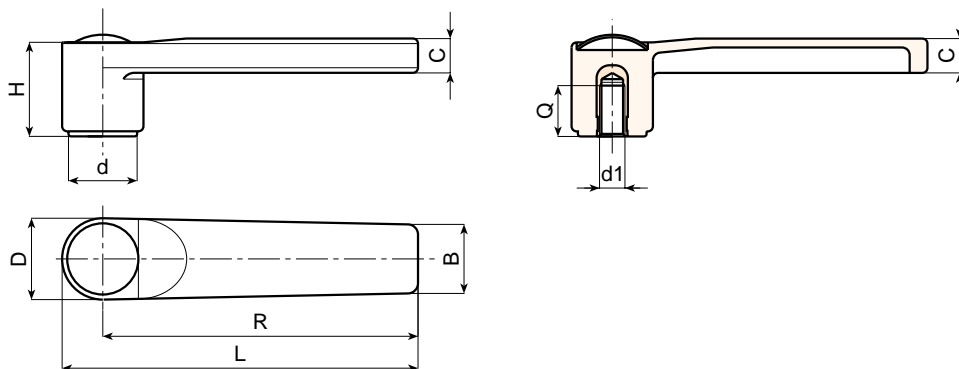

Art.	L	R	H	D	c	B	h1	d	d1	Q	Weight (gr)
A148-125 M10	139	125	37	31	13	26	35	27,5	M10	20	78
A148-125 M12	139	125	37	31	13	26	35	27,5	M12	18	84
A148-125 M14	139	125	37	31	13	26	35	27,5	M14	19	90

ART. A149

LOCKING HANDLE WITH THREADED INSERT

MATERIAL:

Reinforced polyamide.
Oils and greases resistant.

SURFACE:

Satin.

COLOUR:

Black (RAL 9011).

CENTRAL CAP:

Grey polyamide (RAL 7035 code 13).

MAIN INSERT:

Zinc plated steel threaded stud.



SPECIAL REQUESTS:



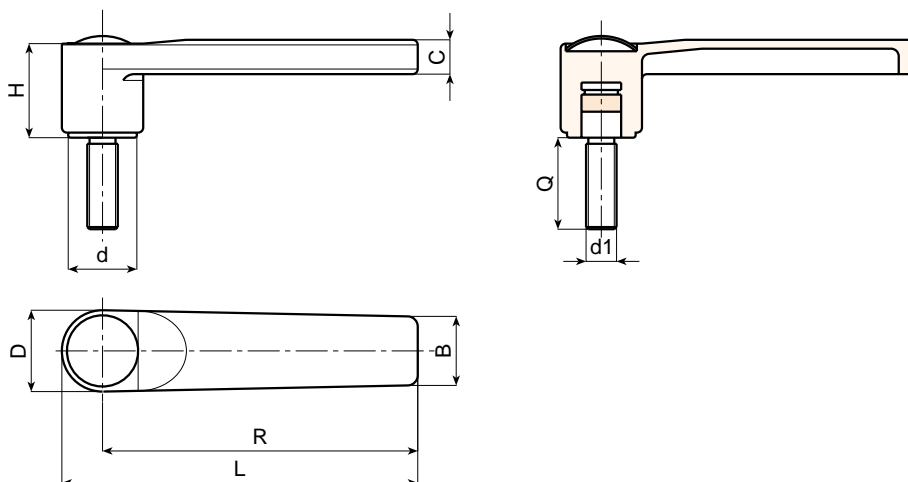







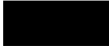

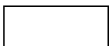

- It is possible to supply the inserts with different lengths, on request and for quantities.
- It is possible to supply the inserts in different materials, on request and for quantities.







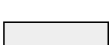







Art.	L	R	H	D	c	B	h1	d	d1	Q	Weight (gr)
A149-125 M10	139	125	37	31	13	26	35	27,5	M10	20-30-50	91-96-106
A149-125 M12	139	125	37	31	13	26	35	27,5	M12	20-30-50	120-112-140
A149-125 M14	139	125	37	31	13	26	35	27,5	M14	30-40-50	148-156-166

COLOUR CHART

R A L

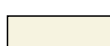
COLOUR		RAL	CODE
Black		9011	01
Orange		2004	02
Orange		2011	03
White		9010	04
Blue		5002	05
Blue		5005	06
Blue		5015	07
Blue		5018	19
Blue		5019	21
Blue		5010	22
Yellow		1007	09
Yellow		1021	10
Grey		7024	12
Grey		7035	13
Red		3000	16
Green		6024	17

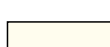
O T H E R C O L O U R S

COLOUR		REF.	CODE
White		-	52
Blue		-	53
Blue	 pant. 645 U		54
Blue	 pant. 300		55
Grey		-	57
Grey		-	59
Grey	 NCS 7500		60
Red		-	64
Red		-	65
Natural		-	66
Green		-	70
Brown		-	71
Cream		-	72
Violet		-	73