

ART. B224

FIXED HANDLE WITH THROUGH HOLE

MATERIAL:

Reinforced polyamide.
Oils and greases resistant.

SURFACE:

Satin.

COLOUR:

Black (RAL 9011).

HOLE :

Smooth right through hole obtained by moulding the plastic.

SPECIAL REQUESTS:

- It is possible to supply colours as shown in the table at page 19, on request and for quantities.

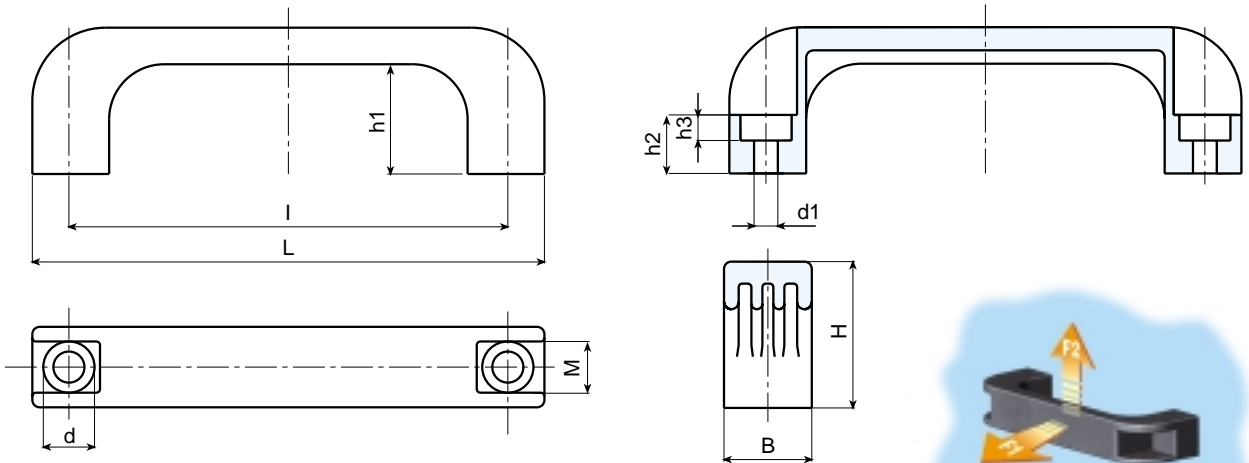

Art.	L	I	B	M	H	h1	h2	h3	d	d1	Weight (gr)	F1 (N)	F2 (N)
B224-94 6.5	110	94	21	13	37	29	13	7	11	6,5	22	2500	1250
B224-117 6.5	140	117	24	13	40	29	15	7	14	6,5	43	4400	3000
B224-117 8.5	140	117	24	13	40	29	15	9	14	8,5	39	4400	3000
B224-120 6.5	140	120	24	14	40	29	15	7	14	6,5	42	4800	3200
B224-120 8.5	140	120	24	14	40	29	15	9	14	8,5	39	4800	3200
B224-132 8.5	151	132	26	14	43	31	16	9	14	8,5	63	3400	3200
B224-180 8.5	200	180	28	17	51	39	21	9	14,5	8,5	74	4000	3000
B224-235 10.5	262	235	32	20	53	40	21	11	17	10,5	123	3800	3000

ART. B226

FIXED HANDLE WITH THREADED INSERT

MATERIAL:

Reinforced polyamide.
Oils and greases resistant.

SURFACE:

Satin.

COLOUR:

Black (RAL 9011).

MAIN INSERT:

Brass blind threaded bush.

SPECIAL REQUESTS:

- It is possible to supply the inserts in different materials, on request and for quantities.
- It is possible to supply colours as shown in the table at page 19, on request and for quantities.

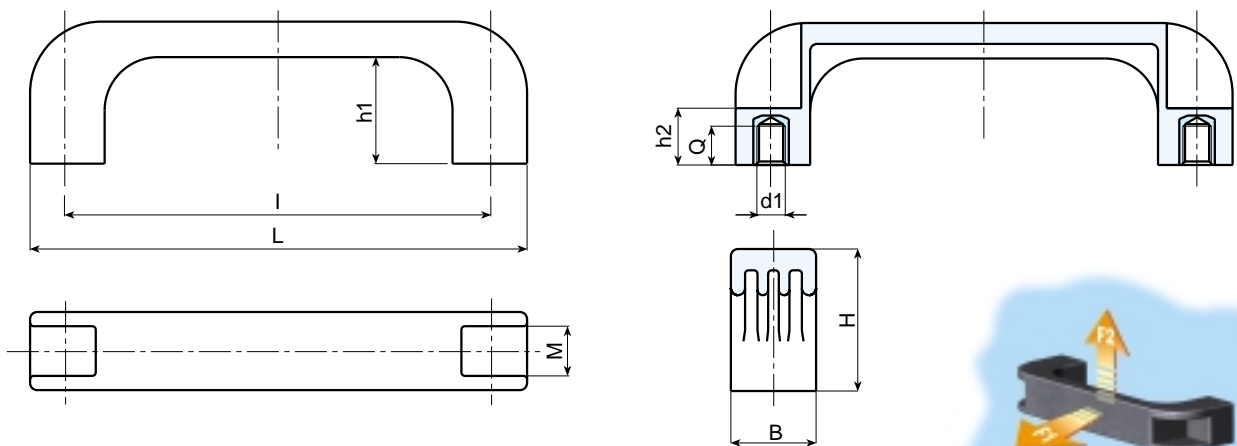

Art.	L	I	B	M	H	h1	h2	Q	d1	Weight (gr)	F1 (N)	F2 (N)
B226-94 M5	110	94	21	13	37	29	13	7	M5	23	4300	1300
B226-94 M6	110	94	21	13	37	29	13	7	M6	23	4300	1300
B226-117 M5	140	117	24	13	40	29	15	10	M5	43	4100	2800
B226-117 M6	140	117	24	13	40	29	15	9	M6	43	4100	2800
B226-117 M8	140	117	24	13	40	29	15	9	M8	43	4100	2800
B226-120 M5	140	120	24	14	40	29	15	10	M5	43	6100	2800
B226-120 M6	140	120	24	14	40	29	15	9	M6	43	6100	2800
B226-120 M8	140	120	24	14	40	29	15	9	M8	43	6100	2800
B226-132 M5	151	132	26	14	43	31	16	10	M5	70	7300	3500
B226-132 M6	151	132	26	14	43	31	16	9	M6	70	7300	3500
B226-132 M8	151	132	26	14	43	31	16	9	M8	70	3700	2800
B226-180 M8	200	180	28	17	51	39	21	14	M8	88	3700	2800
B226-235 M8	262	235	32	20	53	40	21	14	M8	123	4300	3200
B226-235 M10	262	235	32	20	53	40	21	14	M10	123	4300	3200

ART. B236

SOLID HANDLE WITH THREADED INSERT

MATERIAL:

Reinforced polyamide.
Oils and greases resistant.

SURFACE:

Satin.

COLOUR:

Black (RAL 9011).

MAIN INSERT:

Brass blind threaded bush.

SPECIAL REQUESTS:

- It is possible to supply the inserts in different materials, on request and for quantities.
- It is possible to supply colours as shown in the table at page 19, on request and for quantities.

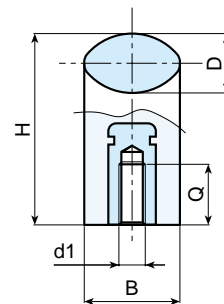
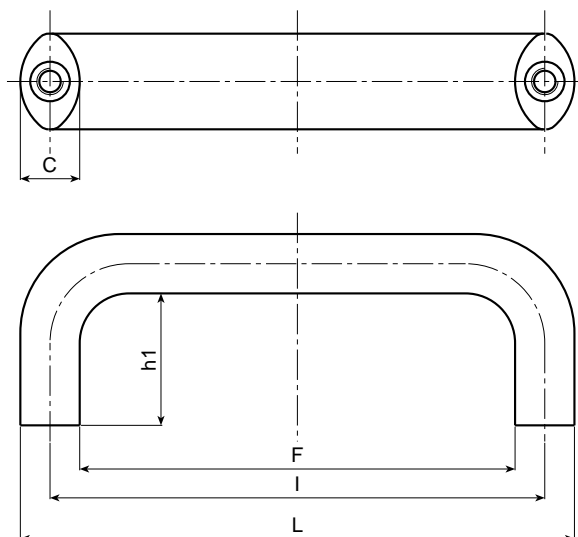

Art.	L	I	F	B	C	D	H	h1	Q	d1	Weight (gr)	F1 (N)	F2 (N)
B236-86 M5	98,5	86	73,5	20	12,5	12,5	40	28	10	M5	40	4000	1500
B236-86 M6	98,5	86	73,5	20	12,5	12,5	40	28	9	M6	40	4000	1500
B236-94 M5	106,5	94	81,5	20	12,5	12,5	40	28	10	M5	40	3300	1600
B236-94 M6	106,5	94	81,5	20	12,5	12,5	40	28	9	M6	40	3300	1600
B236-117 M5	134	117	102	25	16	16	50	34	10	M5	84	4400	1800
B236-117 M6	134	117	102	25	16	16	50	34	9	M6	81	4400	1800
B236-117 M8	134	117	102	25	16	16	50	34	14	M8	80	4400	1800
B236-120 M5	134	120	102	25	16	16	50	34	10	M5	84	5200	2400
B236-120 M6	134	120	102	25	16	16	50	34	9	M6	81	5200	2400
B236-120 M8	134	120	102	25	16	16	50	34	14	M8	80	5200	2400
B236-132 M5	148	132	116	25	16	16	50	34	10	M5	90	3700	2600
B236-132 M6	148	132	116	25	16	16	50	34	9	M6	88	3700	2600
B236-132 M8	148	132	116	25	16	16	50	34	14	M8	85	3700	2600
B236-150 M6	168	150	132	29	18	18	58	40	15	M6	123	5900	1900
B236-150 M8	168	150	132	29	18	18	58	40	14	M8	121	5900	1900
B236-150 M10	168	150	132	29	18	18	58	40	14	M10	119	5900	1900
B236-179 M8	197	179	161	29	18	18	58	40	14	M8	135	3800	3200
B236-179 M10	197	179	161	29	18	18	58	40	14	M10	133	3800	3200

ART. B236 CIN

SOLID HANDLE WITH THREADED STAINLESS STEEL INSERT

INOX

MATERIAL:

Reinforced polyamide.
Oils and greases resistant.

SURFACE:

Satin.

COLOUR:

Black (RAL 9011).

MAIN INSERT:

Stainless steel blind threaded bush (AISI 303).

SPECIAL REQUESTS:

- It is possible to supply colours as shown in the table at page 19, on request and for quantities.

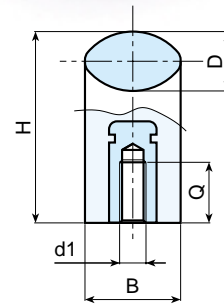
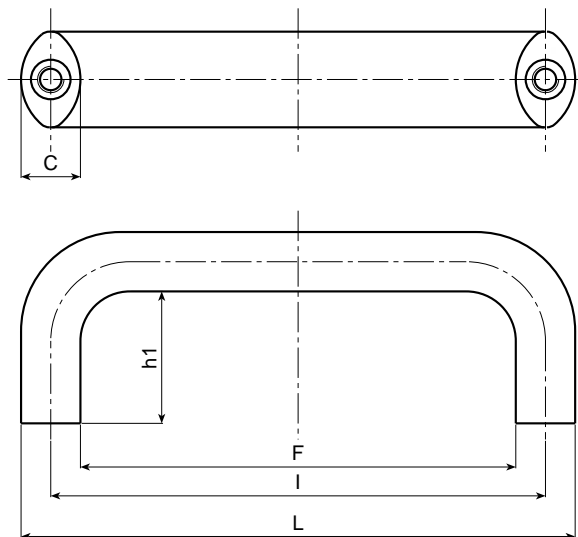

Art.	L	I	F	B	C	D	H	h1	Q	d1	Weight (gr)	F1 (N)	F2 (N)
B236 M5 CIN	98,5	86	73,5	20	12,5	12,5	12,5	40	28	9	M5	40	4000 1500
B236 M6 CIN	98,5	86	73,5	20	12,5	12,5	12,5	40	28	8	M6	40	4000 1500
B236 M5 CIN	106,5	94	81,5	20	12,5	12,5	12,5	40	28	9	M5	40	3300 1600
B236 M6 CIN	106,5	94	81,5	20	12,5	12,5	12,5	40	28	8	M6	40	3300 1600
B236 M5 CIN	134	117	102	25	16	16	16	50	34	9	M5	84	4400 1800
B236 M6 CIN	134	117	102	25	16	16	16	50	34	8	M6	81	4400 1800
B236 M8 CIN	134	117	102	25	16	16	16	50	34	13	M8	80	4400 1800
B236 M5 CIN	134	120	102	25	16	16	16	50	34	9	M5	84	5200 2400
B236 M6 CIN	134	120	102	25	16	16	16	50	34	8	M6	81	5200 2400
B236 M8 CIN	134	120	102	25	16	16	16	50	34	13	M8	80	5200 2400
B236 M5 CIN	148	132	116	25	16	16	16	50	34	9	M5	90	3700 2600
B236 M6 CIN	148	132	116	25	16	16	16	50	34	8	M6	88	3700 2600
B236 M8 CIN	148	132	116	25	16	16	16	50	34	13	M8	85	3700 2600
B236 M6 CIN	168	150	132	29	18	18	18	58	40	13	M6	123	5900 1900
B236 M8 CIN	168	150	132	29	18	18	18	58	40	13	M8	121	5900 1900
B236 M10 CIN	168	150	132	29	18	18	18	58	40	15	M10	119	5900 1900
B236 M8 CIN	197	179	161	29	18	18	18	58	40	13	M8	135	3800 3200
B236 M10 CIN	197	179	161	29	18	18	18	58	40	15	M10	133	3800 3200

ART. B320

HANDLE WITH TUBE D.20

PLASTIC END BRACKET MATERIAL:

Reinforced polyamide.
Oils and greases resistant.

TUBE MATERIAL:

Anodized aluminum UNI 4321.

PLASTIC END BRACKET SURFACE:

Satin.

TUBE SURFACE:

Satin.

PLASTIC END BRACKET COLOUR:

Black (RAL 9011).

TUBE COLOUR:

Silver.

HOLE :

Smooth right through hole obtained by moulding the plastic.

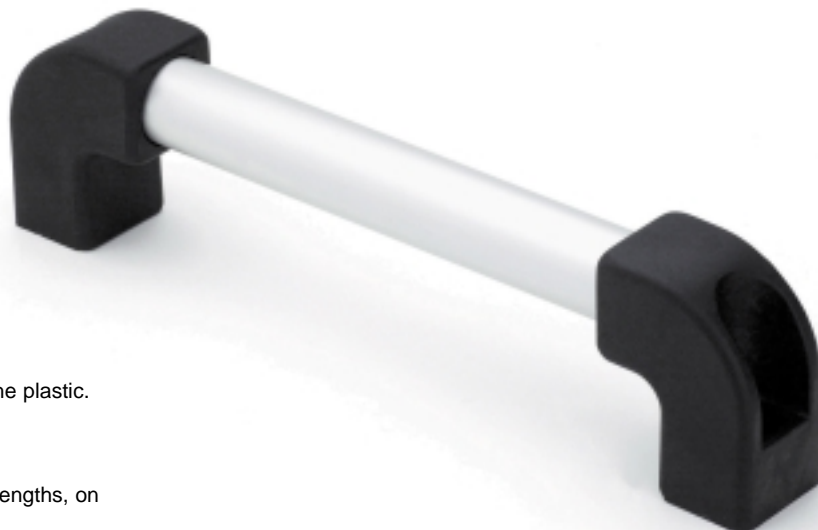

SPECIAL REQUESTS:

- It is possible to supply the handle with different lengths, on request and for quantities.
- It is possible to supply the plastic end bracket with colours as shown in the table at page 19, on request and for quantities.
- It is possible to provide screw cover plugs on request.

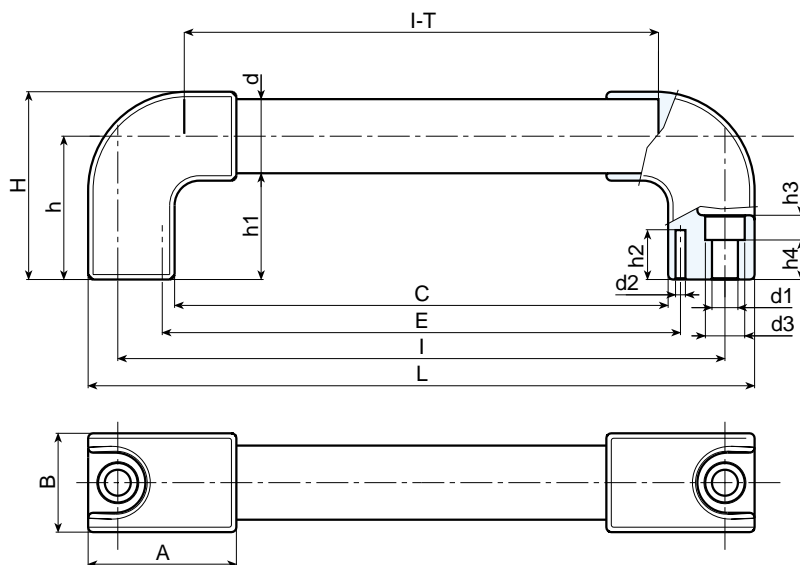

Art.	L	I	C	E	A	B	T	H	h	h1	h4	h3	h2	d	d1	d3	d2	Weight (gr)	F1 (N)	F2 (N)
B320-200	220	200	162	174	50	30	45	57	43	33	7	12,5	15	20	8,5	14,5	4	130	2400	1850
B320-250	270	250	212	224	50	30	45	57	43	33	7	12,5	15	20	8,5	14,5	4	145	1800	1450
B320-300	320	300	262	274	50	30	45	57	43	33	7	12,5	15	20	8,5	14,5	4	155	1500	1500
B320-350	370	350	312	324	50	30	45	57	43	33	7	12,5	15	20	8,5	14,5	4	165	1500	1250
B320-400	420	400	362	374	50	30	45	57	43	33	7	12,5	15	20	8,5	14,5	4	176	2400	850
B320-500	520	500	462	474	50	30	45	57	43	33	7	12,5	15	20	8,5	14,5	4	200	1000	800
B320-600	620	600	562	574	50	30	45	57	43	33	7	12,5	15	20	8,5	14,5	4	225	900	750
B320-700	720	700	662	674	50	30	45	57	43	33	7	12,5	15	20	8,5	14,5	4	250	600	600

ART. B322

HANDLE WITH TUBE D.20

PLASTIC END BRACKET MATERIAL:

Reinforced polyamide.
Oils and greases resistant.

TUBE MATERIAL:

Anodized aluminum UNI 4321.

PLASTIC END BRACKET SURFACE:

Satin.

TUBE SURFACE:

Satin.

PLASTIC END BRACKET COLOUR:

Black (RAL 9011).

TUBE COLOUR:

Black marbled.

HOLE :

Smooth right through hole obtained by moulding the plastic.



SPECIAL REQUESTS:

- It is possible to supply the handle with different lengths, on request and for quantities.
- It is possible to supply the plastic end bracket with colours as shown in the table at page 19, on request and for quantities.
- It is possible to provide screw cover plugs on request.

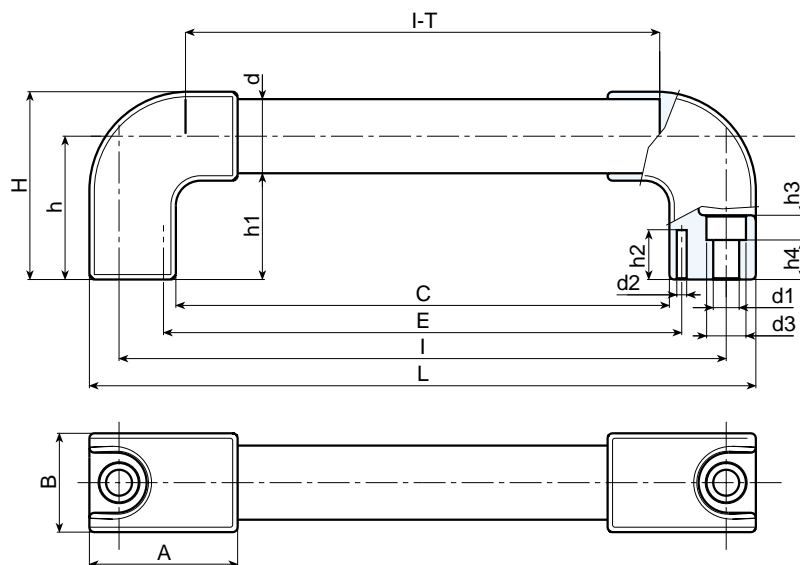

Art.	L	I	C	E	A	B	T	H	h	h1	h4	h3	h2	d	d1	d3	d2	Weight (gr)	F1 (N)	F2 (N)
B322-200	220	200	162	174	50	30	45	57	43	33	7	12,5	15	20	8,5	14,5	4	130	2400	1850
B322-250	270	250	212	224	50	30	45	57	43	33	7	12,5	15	20	8,5	14,5	4	145	1800	1450
B322-300	320	300	262	274	50	30	45	57	43	33	7	12,5	15	20	8,5	14,5	4	155	1500	1500
B322-350	370	350	312	324	50	30	45	57	43	33	7	12,5	15	20	8,5	14,5	4	165	1500	1250
B322-400	420	400	362	374	50	30	45	57	43	33	7	12,5	15	20	8,5	14,5	4	176	2400	850
B322-500	520	500	462	474	50	30	45	57	43	33	7	12,5	15	20	8,5	14,5	4	200	1000	800
B322-600	620	600	562	574	50	30	45	57	43	33	7	12,5	15	20	8,5	14,5	4	225	900	750
B322-700	720	700	662	674	50	30	45	57	43	33	7	12,5	15	20	8,5	14,5	4	250	600	600

ART. B330

HANDLE WITH TUBE D.30

PLASTIC END BRACKET MATERIAL:

Reinforced polyamide.
Oils and greases resistant.

TUBE MATERIAL:

Anodized aluminum UNI 4321.

PLASTIC END BRACKET SURFACE:

Satin.

TUBE SURFACE:

Satin.

PLASTIC END BRACKET COLOUR:

Black (RAL 9011).

TUBE COLOUR:

Silver.

HOLE :

Smooth right through hole obtained by moulding the plastic.

SPECIAL REQUESTS:

- It is possible to supply the handle with different lengths, on request and for quantities.
- It is possible to supply the plastic end bracket with colours as shown in the table at page 19, on request and for quantities.
- It is possible to provide screw cover plugs on request.

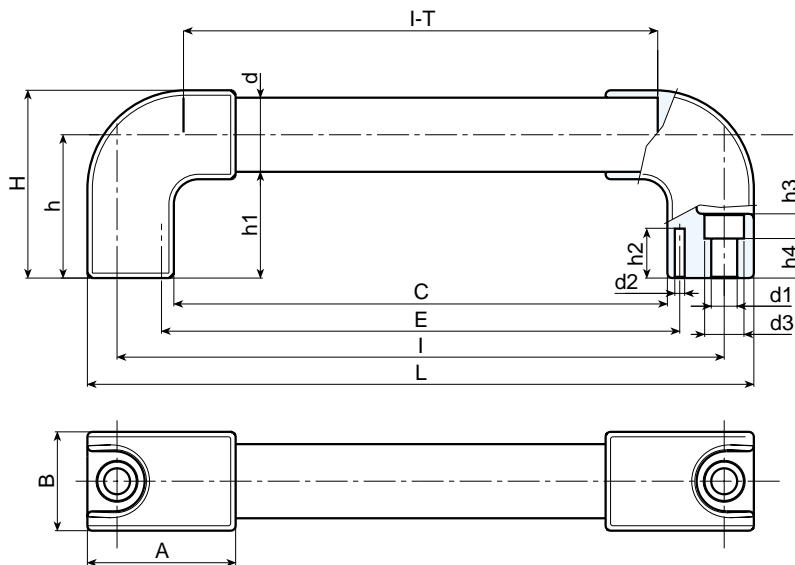
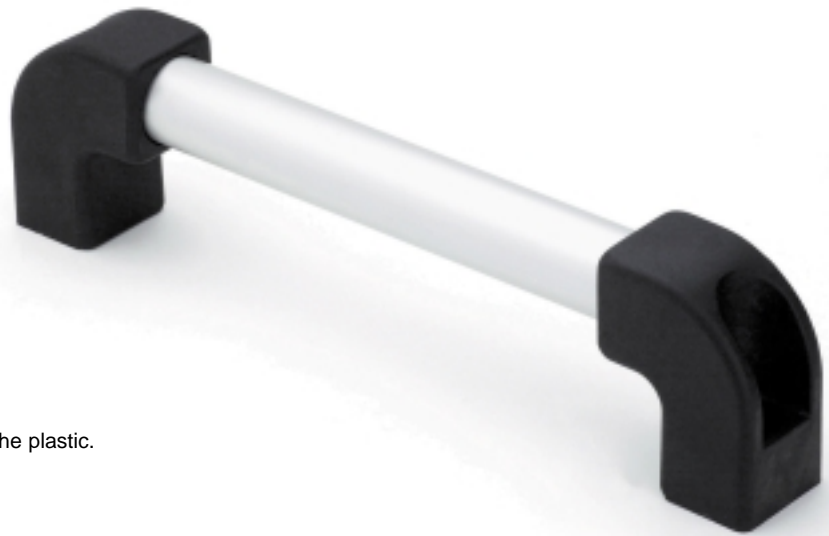

Art.	L	I	C	E	A	B	T	H	h	h1	h4	h3	h2	d	d1	d3	d2	Weight (gr)	F1 (N)	F2 (N)
B330-200	224	200	154	164	60	40	54	77	58	43	12	15	19	30	10,5	16	4	235	3400	2900
B330-250	274	250	204	214	60	40	54	77	58	43	12	15	19	30	10,5	16	4	250	3800	3200
B330-300	324	300	254	264	60	40	54	77	58	43	12	15	19	30	10,5	16	4	270	3200	2900
B330-350	374	350	304	314	60	40	54	77	58	43	12	15	19	30	10,5	16	4	285	2700	2400
B330-400	424	400	354	364	60	40	54	77	58	43	12	15	19	30	10,5	16	4	305	2400	2200
B330-500	524	500	454	464	60	40	54	77	58	43	12	15	19	30	10,5	16	4	340	1900	1700
B330-600	624	600	554	564	60	40	54	77	58	43	12	15	19	30	10,5	16	4	370	1600	1400
B330-700	724	700	654	664	60	40	54	77	58	43	12	15	19	30	10,5	16	4	405	1400	1250

ART. B332

HANDLE WITH TUBE D.30

PLASTIC END BRACKET MATERIAL:

Reinforced polyamide.
Oils and greases resistant.

TUBE MATERIAL:

Anodized aluminum UNI 4321.

PLASTIC END BRACKET SURFACE:

Satin.

TUBE SURFACE:

Satin.

PLASTIC END BRACKET COLOUR:

Black (RAL 9011).

TUBE COLOUR:

Black marbled.

HOLE :

Smooth right through hole obtained by moulding the plastic.



SPECIAL REQUESTS:

- It is possible to supply the handle with different lengths, on request and for quantities.
- It is possible to supply the plastic end bracket with colours as shown in the table at page 19, on request and for quantities.
- It is possible to provide screw cover plugs on request.

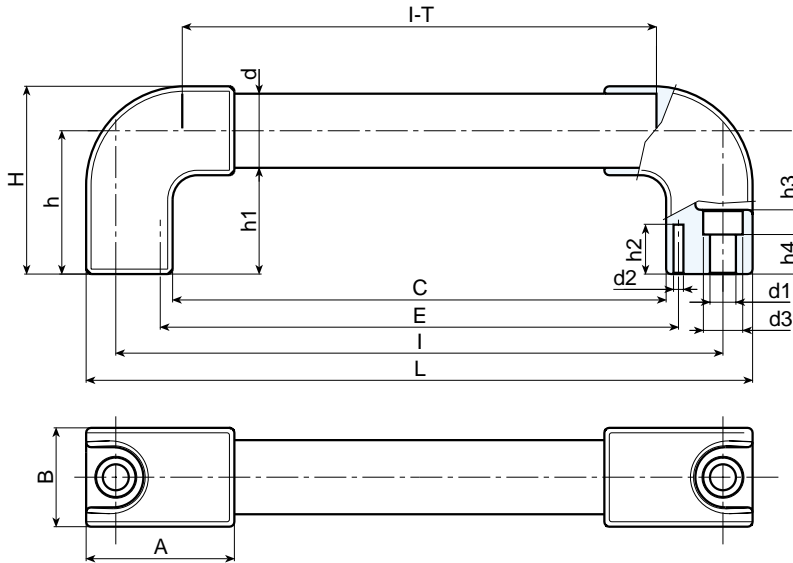

Art.	L	I	C	E	A	B	T	H	h	h1	h4	h3	h2	d	d1	d3	d2	Weight (gr)	F1 (N)	F2 (N)
B332-200	224	200	154	164	60	40	54	77	58	43	12	15	19	30	10,5	16	4	235	3400	2900
B332-250	274	250	204	214	60	40	54	77	58	43	12	15	19	30	10,5	16	4	250	3800	3200
B332-300	324	300	254	264	60	40	54	77	58	43	12	15	19	30	10,5	16	4	270	3200	2900
B332-350	374	350	304	314	60	40	54	77	58	43	12	15	19	30	10,5	16	4	285	2700	2400
B332-400	424	400	354	364	60	40	54	77	58	43	12	15	19	30	10,5	16	4	305	2400	2200
B332-500	524	500	454	464	60	40	54	77	58	43	12	15	19	30	10,5	16	4	340	1900	1700
B332-600	624	600	554	564	60	40	54	77	58	43	12	15	19	30	10,5	16	4	370	1600	1400
B332-700	724	700	654	664	60	40	54	77	58	43	12	15	19	30	10,5	16	4	405	1400	1250

ART. B331

BRACKET FOR HANDLE WITH TUBE D.30

MATERIAL:

Reinforced polyamide.
Oils and greases resistant.

SURFACE:

Satin.

COLOUR:

Black (RAL 9011).

HOLE :

Smooth right through hole obtained by moulding the plastic.

SPECIAL REQUESTS:



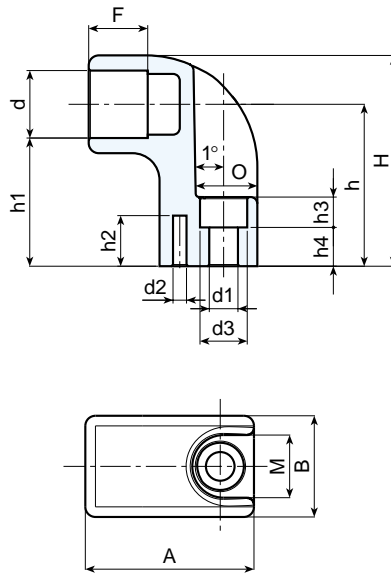







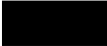

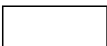

- It is possible to supply colours as shown in the table at page 19, on request and for quantities.
- It is possible to provide screw cover plugs on request.







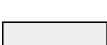







Art.	d	d1	d3	d2	A	B	H	h	h1	h4	h3	h2	M	O	F	Weight (gr)
B331	30	10,5	16	4	60	40	77	58	43	12	15	19	23	22	21	92

COLOUR CHART

R A L

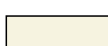
COLOUR		RAL	CODE
Black		9011	01
Orange		2004	02
Orange		2011	03
White		9010	04
Blue		5002	05
Blue		5005	06
Blue		5015	07
Blue		5018	19
Blue		5019	21
Blue		5010	22
Yellow		1007	09
Yellow		1021	10
Grey		7024	12
Grey		7035	13
Red		3000	16
Green		6024	17

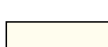
O T H E R C O L O U R S

COLOUR		REF.	CODE
White		-	52
Blue		-	53
Blue	 pant. 645 U		54
Blue	 pant. 300		55
Grey		-	57
Grey		-	59
Grey	 NCS 7500		60
Red		-	64
Red		-	65
Natural		-	66
Green		-	70
Brown		-	71
Cream		-	72
Violet		-	73