

# ART. K900

## SOLID CONTROL HANDWHEEL FOR BUILT-IN POSITION INDICATOR

### MATERIAL:

Reinforced and stabilised polyamide.  
Oils and greases resistant.

### SURFACE:

Satin.

### HANDWHEEL COLOUR:

Black (RAL 9011).

### ATTACHABLE POSITION INDICATOR:

SIKO gravity indicator type "S" or "SZ". The indicator can only be used in a vertical position (horizontal machine axle). The indicator and the d7 grub screw must be purchased separately. For further details see page 12.

(\*) SIKO position indicator S50/1 can be mounted with adapter KS80-50.

(+) SIKO position indicator S80/1 can be mounted with adapter KS120-80.

### MAIN INSERT:

Zinc plated steel right through bored bush with H7 tolerance.

For fixing systems, or execution of tabs or square holes, please refer to the technical notes attached to the catalogue.

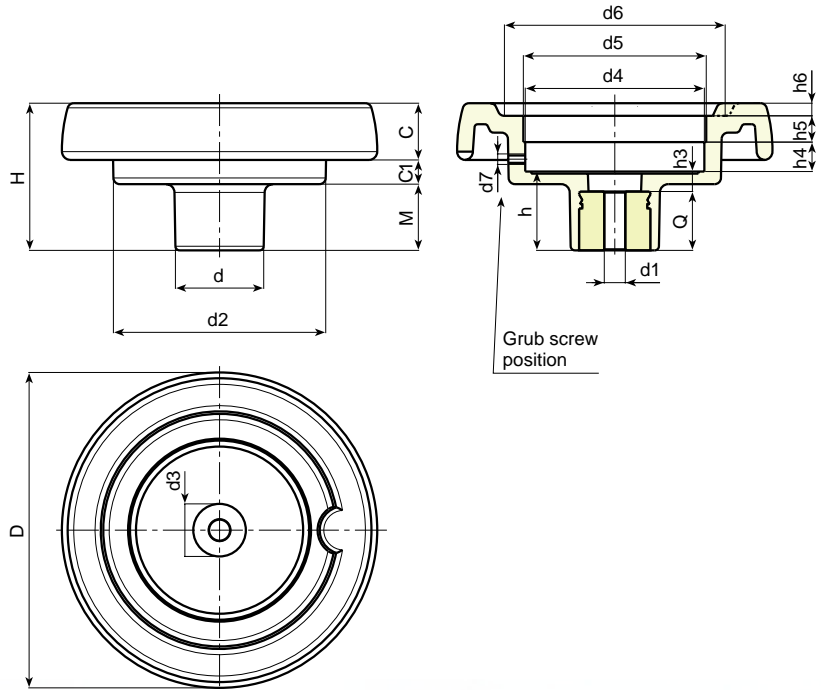

### SPECIAL REQUESTS:

- It is possible to supply the inserts with d1 diameter by customer design, on request and for quantities.
- It is possible to supply the inserts in different materials, on request and for quantities.
- It is possible to supply the inserts with different treatment-finishes, on request and for quantities.
- On request and for special quantities the indicator seat can be changed.
- It is possible to supply the complete handwheel with colours as shown in the table at page 15, on request and for quantities.



Art.	D	H	d	d2	M	C	C1	d3	d4	d5	d6	d7	h	h3	h4	h5	h6	d1 H7	dm	Q	Weight (gr)
K900-87 T50 D5.8	86	53	32	62	21	17	15	20	50,5	52 (S50/1)	63	M6	26,5	6,5	11,5	12	3	5,8 H9	12	20	155
K900-87 T50 D10	86	53	32	62	21	17	15	20	50,5	52 (S50/1)	63	M6	26,5	6,5	11,5	12	3	10	12	20	155
K900-100 T50 D6.8	99	55,5	32	63	23,5	20,5	11,5	20	50,5	52 (S50/1)	68	M6	29	9	11,5	12	3,5	6,8 H9	12	20	170
K900-100 T50 D10	99	55,5	32	63	23,5	20,5	11,5	20	50,5	52 (S50/1)	68	M6	29	9	11,5	12	3,5	10	12	20	170
K900-130 T80 D6.8	129	64,5	42	100	27,5	23	14	29	85,5	87 (S80/1) *	90	M6	34	10	13,5	12,5	5	6,8 H9	20	24	350
K900-130 T80 D12	129	64,5	42	100	27,5	23	14	29	85,5	87 (S80/1) *	90	M6	34	10	13,5	12,5	5	12	20	24	348
K900-150 T80 D6.8	149	69	42	101	31	25,5	12,5	29	85,5	87 (S80/1) *	106	M6	37	9	13,5	12,5	6,5	6,8 H9	20	28	430
K900-150 T80 D14	149	69	42	101	31	25,5	12,5	29	85,5	87 (S80/1) *	106	M6	37	9	13,5	12,5	6,5	14	20	28	427
K900-175 T80 D6.8	175	72	40	115	28,5	32	11,5	25	85,5	87 (S80/1) *	126,5	M6	38	10	12,5	14	8	6,8 H9	20	28	650
K900-175 T80 D16	175	72	40	115	28,5	32	11,5	25	85,5	87 (S80/1) *	126,5	M6	38	10	12,5	14	8	16	20	28	645
K900-200 T120 D6.8	199	71	46	137	24	32	15	29	124	125,5 (S120/1) +	144	M6	34	11	13,5	12,5	10	6,8 H9	22	23	810
K900-200 T120 D20	199	71	46	137	24	32	15	29	124	125,5 (S120/1) +	144	M6	34	11	13,5	12,5	10	20	22	23	804

It's possible to increase the hole, by boring, until **dm**.

Next to the d5 diameter is shown a mountable Siko indicator. For information on the indicator visit the SIKO web site at [www.siko.de](http://www.siko.de).

# ART. K902

## SOLID CONTROL HANDWHEEL FOR BUILT-IN POSITION INDICATOR WITH REVOLVING HANDLE

### MATERIAL:

Reinforced and stabilised polyamide.  
Oils and greases resistant.

### SURFACE:

Satin.

### HANDWHEEL AND HANDLE COLOUR:

Black (RAL 9011).

### ATTACHABLE POSITION INDICATOR:

SIKO gravity indicator type "S" or "SZ". The indicator can only be used in a vertical position (horizontal machine axle). The indicator and the d7 grub screw must be purchased separately. For further details see page 12.

(\*) SIKO position indicator S50/1 can be mounted with adapter KS80-50.

(+) SIKO position indicator S80/1 can be mounted with adapter KS120-80.

### MAIN INSERT:

Zinc plated steel right through bored bush with H7 tolerance.

### SIDE INSERT:

Brass right through threaded bush.

### SIDE HANDLE:

Revolving handle Art. M144  
(see chapter M on page 6).

For fixing systems, or execution of tabs or square holes, please refer to the technical notes attached to the catalogue.

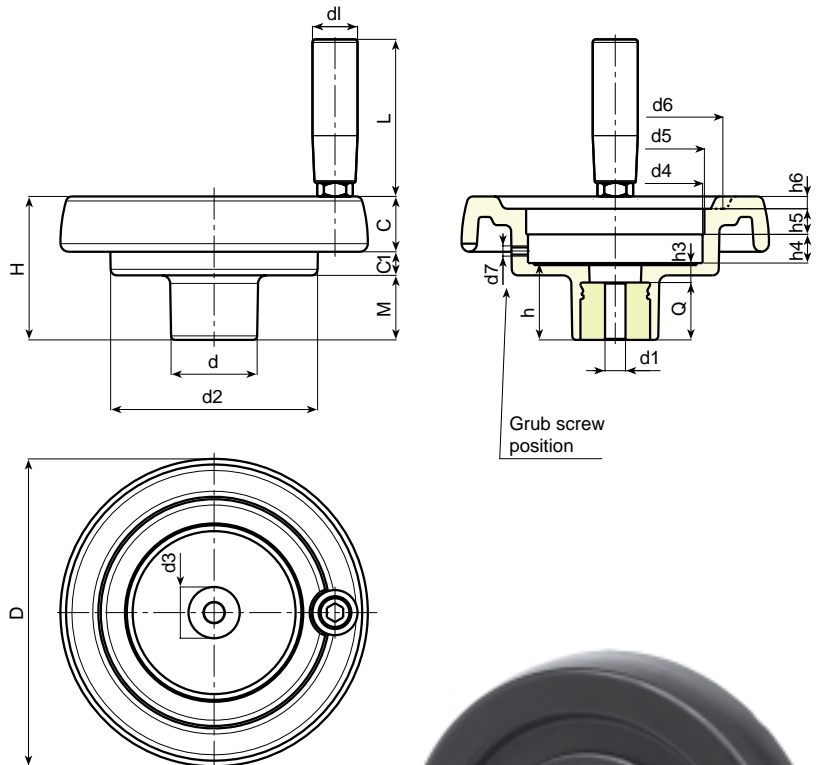

### SPECIAL REQUESTS:

- It is possible to supply the inserts with d1 diameter by customer design, on request and for quantities.
- It is possible to supply the inserts in different materials, on request and for quantities.
- It is possible to supply the inserts with different treatment-finishes, on request and for quantities.
- On request and for special quantities the indicator seat can be changed.
- It is possible to supply the complete handwheel with colours as shown in the table at page 15, on request and for quantities.

Art.	D	H	d	d2	M	C	C1	d3	d4	d5	d6	d7	h	h3	h4	h5	h6	d1 H7	dm	Q	dl	L	Weight (gr)
K902-87 T50 D5.8	86	53	32	62	21	17	15	20	50,5	52 (S50/1)	63	M6	26,5	6,5	11,5	12	3	5,8 H9	12	20	20	56	185
K902-87 T50 D10	86	53	32	62	21	17	15	20	50,5	52 (S50/1)	63	M6	26,5	6,5	11,5	12	3	10	12	20	20	56	185
K902-100 T50 D6.8	99	55,5	32	63	23,5	20,5	11,5	20	50,5	52 (S50/1)	68	M6	29	9	11,5	12	3,5	6,8 H9	12	20	20	56	200
K902-100 T50 D10	99	55,5	32	63	23,5	20,5	11,5	20	50,5	52 (S50/1)	68	M6	29	9	11,5	12	3,5	10	12	20	20	56	200
K902-130 T80 D6.8	129	64,5	42	100	27,5	23	14	29	85,5	87 (S80/1) *	90	M6	34	10	13,5	12,5	5	6,8 H9	20	24	21	65	406
K902-130 T80 D12	129	64,5	42	100	27,5	23	14	29	85,5	87 (S80/1) *	90	M6	34	10	13,5	12,5	5	12	20	24	21	65	404
K902-150 T80 D6.8	149	69	42	101	31	25,5	12,5	29	85,5	87 (S80/1) *	106	M6	37	9	13,5	12,5	6,5	6,8 H9	20	28	23	76	530
K902-150 T80 D14	149	69	42	101	31	25,5	12,5	29	85,5	87 (S80/1) *	106	M6	37	9	13,5	12,5	6,5	14	20	28	23	76	527
K902-175 T80 D6.8	175	72	40	115	28,5	32	11,5	25	85,5	87 (S80/1) *	126,5	M6	38	10	12,5	14	8	6,8 H9	20	28	25	86	760
K902-175 T80 D16	175	72	40	115	28,5	32	11,5	25	85,5	87 (S80/1) *	126,5	M6	38	10	12,5	14	8	16	20	28	25	86	755
K902-200 T120 D6.8	199	71	46	137	24	32	15	29	124	125,5 (S120/1) +	144	M6	34	11	13,5	12,5	10	6,8 H9	22	23	25	86	920
K902-200 T120 D20	199	71	46	137	24	32	15	29	124	125,5 (S120/1) +	144	M6	34	11	13,5	12,5	10	20	22	23	25	86	914

It's possible to increase the hole, by boring, until **dm**.

Next to the d5 diameter is shown a mountable Siko indicator. For information on the indicator visit the SIKO web site at [www.siko.de](http://www.siko.de).

## ALTERNATIVES



ART. K907



ART. K906



ART. K908



STANDARD ART. K SERIES

### ART. K907

#### SOLID CONTROL HANDWHEEL FOR POSITION INDICATOR WITH REVOLVING HANDLE M145

Art.	D	d1	L	Weight (gr)	OTHER VALUES
K907-87	86	20	55	187	see table K902
K907-100	99	20	55	205	see table K902
K907-130	129	23	66	424	see table K902
K907-150	149	25	76	516	see table K902
K907-175	175	25	87	745	see table K902
K907-200	199	25	87	900	see table K902

#### SIDE HANDLE:

Revolving Handle Art. M145 (see chapter M page 8).

For details of the handwheel see those for art. K902.

### ART. K906

#### SOLID CONTROL HANDWHEEL FOR POSITION INDICATOR WITH REVOLVING HANDLE M129

Art.	D	d1	L	Weight (gr)	OTHER VALUES
K906-87	86	20	52	197	see table K902
K906-100	99	20	52	212	see table K902
K906-130	129	23	62	410	see table K902
K906-150	149	25	72	522	see table K902
K906-175	175	25	81	750	see table K902
K906-200	199	25	81	910	see table K902

#### SIDE HANDLE:

Revolving Handle Art. M129 (see chapter M page 9).

For details of the handwheel see those for art. K902.

### ART. K908

#### SOLID CONTROL HANDWHEEL FOR POSITION INDICATOR WITH REVOLVING HANDLE "EUROMODEL" M202

Art.	D	d1	L	Weight (gr)	OTHER VALUES
K908-150	149	40	64	525	see table K902
K908-175	175	40	64	745	see table K902
K908-200	199	40	64	905	see table K902

#### SIDE HANDLE:

Revolving Handle Art. M202 (see chapter M page 18).

For details of the handwheel see those for art. K902.

### STANDARD ART. K SERIES

#### BASE FOR SOLID CONTROL HANDWHEEL FOR POSITION INDICATOR WITH PROVISION FOR HANDLE

Art.	D	d1	side handle threading	Weight (gr)	OTHER VALUES
K87	86	5,8 H9	M6	155	see table K902
K100	99	6,8 H9	M6	170	see table K902
K130	129	6,8 H9	M8	350	see table K902
K150	149	6,8 H9	M10	430	see table K902
K175	175	6,8 H9	M10	650	see table K902
K200	199	6,8 H9	M10	810	see table K902

This article is recommended for distributors.

For details of the handwheel see those for art. K902.

# ART. K901

## SOLID CONTROL HANDWHEEL FOR BUILT-IN POSITION INDICATOR AND LOCKING HANDWHEEL

### MATERIAL:

Reinforced and stabilised polyamide.  
Oils and greases resistant.

### SURFACE:

Satin.

### HANDWHEEL COLOUR:

Black (RAL 9011).

### ATTACHABLE POSITION INDICATOR:

SIKO gravity indicator type "S" or "SZ". The indicator can only be used in a vertical position (horizontal machine axle). The indicator and the d7 grub screw must be purchased separately. For further details see page 12.

(\*) SIKO position indicator S50/1 can be mounted with adapter KS80-50.

(+) SIKO position indicator S80/1 can be mounted with adapter KS120-80.

### MAIN INSERT:

Zinc plated steel right through bored bush with H7 tolerance.

### LOCKING HANDWHEEL:

Cylindrical handwheel G793-36 with threaded stud (see chapter G page 12). Black (RAL 9011).

**Caution:** the Q2 dimension of the handwheel must be chosen by the customer according to the dimensions of the machinery on which it will be installed. For model K901-130 the locking handwheel is replaced with the wingnut L751-32 (see chapter L page 10).

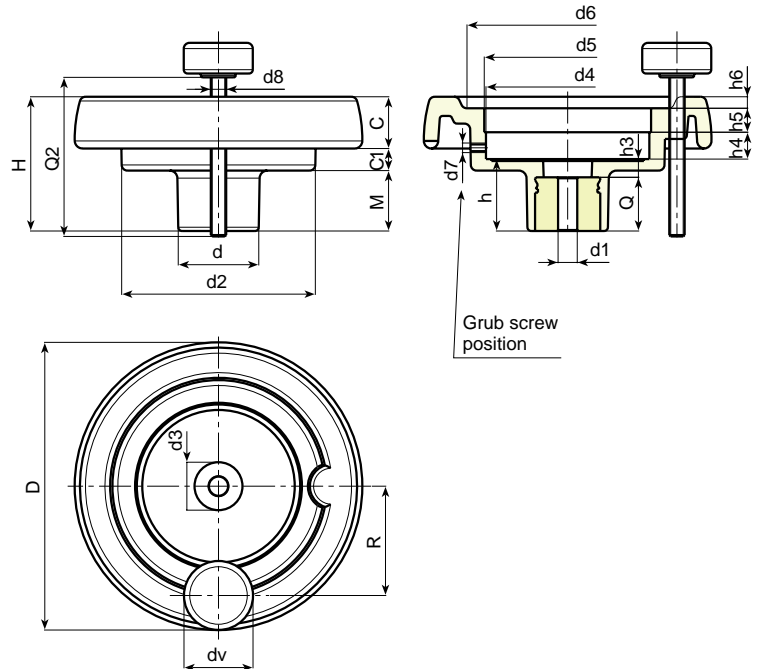

For fixing systems, or execution of tabs or square holes, please refer to the technical notes attached to the catalogue.

### SPECIAL REQUESTS:

- It is possible to supply the inserts with d1 diameter by customer design, on request and for quantities.
- It is possible to supply the inserts in different materials, on request and for quantities.
- It is possible to supply the inserts with different treatment-finishes, on request and for quantities.
- On request and for special quantities the indicator seat can be changed.
- It is possible to supply the complete handwheel with colours as shown in the table at page 15, on request and for quantities.



Art.	D	H	d	d2	M	C	C1	d3	d4	R	d5	d6	d8	d7	h	h3	h4	h5	h6	d1 H7	dm	Q	Weight (gr)
K901-130 T80 D5.8	129	64,5	42	100	27,5	23	14	29	85,5	54	87 (S80/1) *	90	M8	M6	34	10	13,5	12,5	5	6,8 H9	20	24	370
K901-130 T80 D12	129	64,5	42	100	27,5	23	14	29	85,5	54	87 (S80/1) *	90	M8	M6	34	10	13,5	12,5	5	12	20	24	368
K901-150 T80 D6.8	149	69	42	101	31	25,5	12,5	29	85,5	57	87 (S80/1) *	106	M8	M6	37	9	13,5	12,5	6,5	6,8 H9	20	28	470
K901-150 T80 D14	149	69	42	101	31	25,5	12,5	29	85,5	57	87 (S80/1) *	106	M8	M6	37	9	13,5	12,5	6,5	14	20	28	467
K901-175 T80 D6.8	175	72	40	115	28,5	32	11,5	25	85,5	60	87 (S80/1) *	126,5	M8	M6	38	10	12,5	14	8	6,8 H9	20	28	690
K901-175 T80 D16	175	72	40	115	28,5	32	11,5	25	85,5	60	87 (S80/1) *	126,5	M8	M6	38	10	12,5	14	8	16	20	28	685
K901-200 T120 D6.8	199	71	46	137	24	32	15	29	124	74	125,5 (S120/1) +	144	M8	M6	34	11	13,5	12,5	10	6,8 H9	22	23	850
K901-200 T120 D20	199	71	46	137	24	32	15	29	124	74	125,5 (S120/1) +	144	M8	M6	34	11	13,5	12,5	10	20	22	23	843

Q2 = On request.

dv = 36 mm (K901-130 dv = 32 mm).

It's possible to increase the hole, by boring, until dm.

Next to the d5 diameter is shown a mountable Siko indicator. For information on the indicator visit the SIKO web site at [www.siko.de](http://www.siko.de).

# ART. K903

## SOLID CONTROL HANDWHEEL FOR BUILT-IN POSITION INDICATOR WITH REVOLVING HANDLE AND LOCKING HANDWHEEL

### MATERIAL:

Reinforced and stabilised polyamide.  
Oils and greases resistant.

### SURFACE:

Satin.

### HANDWHEEL AND HANDLE COLOUR:

Black (RAL 9011).

### ATTACHABLE POSITION INDICATOR:

SIKO gravity indicator type "S" or "SZ". The indicator can only be used in a vertical position (horizontal machine axle). The indicator and the d7 grub screw must be purchased separately. For further details see page 12.

(\* SIKO position indicator S50/1 can be mounted with adapter KS80-50.

(+ SIKO position indicator S80/1 can be mounted with adapter KS120-80.

### MAIN INSERT:

Zinc plated steel right through bored bush with H7 tolerance.

### SIDE INSERT:

Brass right through threaded bush.

### SIDE HANDLE:

Revolving handle Art. M144 (see chapter M on page 6).

### LOCKING HANDWHEEL:

Cylindrical handwheel G793-36 with threaded stud (see chapter G page 12). Black (RAL 9011).

**Caution:** the Q2 dimension of the handwheel must be chosen by the customer according to the dimensions of the machinery on which it will be installed. For model K903-130 the locking handwheel is replaced with the wingnut L751-32 (see chapter L page 10).

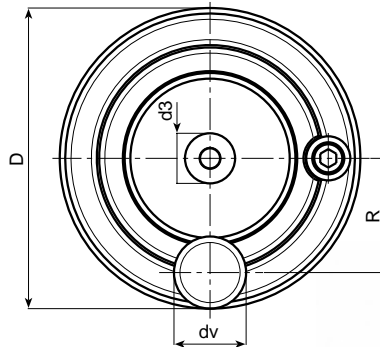
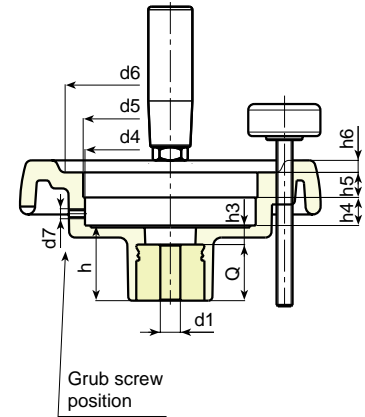
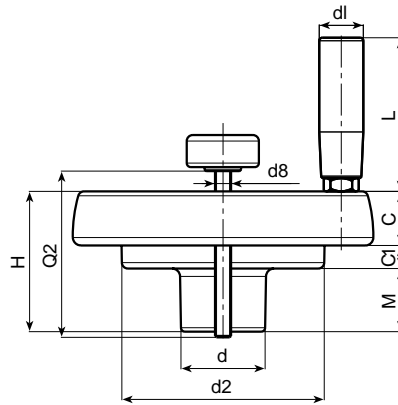

For fixing systems, or execution of tabs or square holes, please refer to the technical notes attached to the catalogue.

### SPECIAL REQUESTS:

- It is possible to supply the inserts with d1 diameter by customer design, on request and for quantities.
- It is possible to supply the inserts in different materials, on request and for quantities.
- It is possible to supply the inserts with different treatment-finishes, on request and for quantities.
- On request and for special quantities the indicator seat can be changed.
- It is possible to supply the complete handwheel with colours as shown in the table at page 15, on request and for quantities.

Art.	D	H	d	d2	M	C	C1	d3	d4	R	d5	d6	d8	d7	h	h3	h4	h5	h6	d1 H7	dm	Q	dl	L	Weight (gr)
K903-130 T80 D5.8	129	64,5	42	100	27,5	23	14	29	85,5	54	87 (S80/1) *	90	M8	M6	34	10	13,5	12,5	5	6,8 H9	20	24	21	65	426
K903-130 T80 D12	129	64,5	42	100	27,5	23	14	29	85,5	54	87 (S80/1) *	90	M8	M6	34	10	13,5	12,5	5	12	20	24	21	65	424
K903-150 T80 D6.8	149	69	42	101	31	25,5	12,5	29	85,5	57	87 (S80/1) *	106	M8	M6	37	9	13,5	12,5	6,5	6,8 H9	20	28	23	76	555
K903-150 T80 D14	149	69	42	101	31	25,5	12,5	29	85,5	57	87 (S80/1) *	106	M8	M6	37	9	13,5	12,5	6,5	14	20	28	23	76	550
K903-175 T80 D6.8	175	72	40	115	28,5	32	11,5	25	85,5	60	87 (S80/1) *	126,5	M8	M6	38	10	12,5	14	8	6,8 H9	20	28	25	86	782
K903-175 T80 D16	175	72	40	115	28,5	32	11,5	25	85,5	60	87 (S80/1) *	126,5	M8	M6	38	10	12,5	14	8	16	20	28	25	86	777
K903-200 T120 D6.8	199	71	46	137	24	32	15	29	124	74	125,5 (S120/1) +	144	M8	M6	34	11	13,5	12,5	10	6,8 H9	22	23	25	86	950
K903-200 T120 D20	199	71	46	137	24	32	15	29	124	74	125,5 (S120/1) +	144	M8	M6	34	11	13,5	12,5	10	20	22	23	25	86	943

Q2 = On request.

dv = 36 mm (K903-130 dv = 32 mm).

It's possible to increase the hole, by boring, until dm.

Next to the d5 diameter is shown a mountable Siko indicator. For information on the indicator visit the SIKO web site at [www.siko.de](http://www.siko.de).

# ART. K904

## SOLID CONTROL HANDWHEEL FOR BUILT-IN POSITION INDICATOR WITH REVOLVING, FOLDING HANDLE

### MATERIAL:

Reinforced and stabilised polyamide.  
Oils and greases resistant.

### SURFACE:

Satin.

### HANDWHEEL AND HANDLE COLOUR:

Black (RAL 9011).

### ATTACHABLE POSITION INDICATOR:

SIKO gravity indicator type "S" or "SZ". The indicator can only be used in a vertical position (horizontal machine axle). The indicator and the d7 grub screw must be purchased separately. For further details see page 12.

(\*) SIKO position indicator S50/1 can be mounted with adapter KS80-50.

(+) SIKO position indicator S80/1 can be mounted with adapter KS120-80.

### MAIN INSERT:

Zinc plated steel right through bored bush with H7 tolerance.

### SIDE INSERT:

Brass right through threaded bush.

### SIDE HANDLE:

Revolving handle and folding Art. M136 (see chapter M on page 10).

For fixing systems, or execution of tabs or square holes, please refer to the technical notes attached to the catalogue.

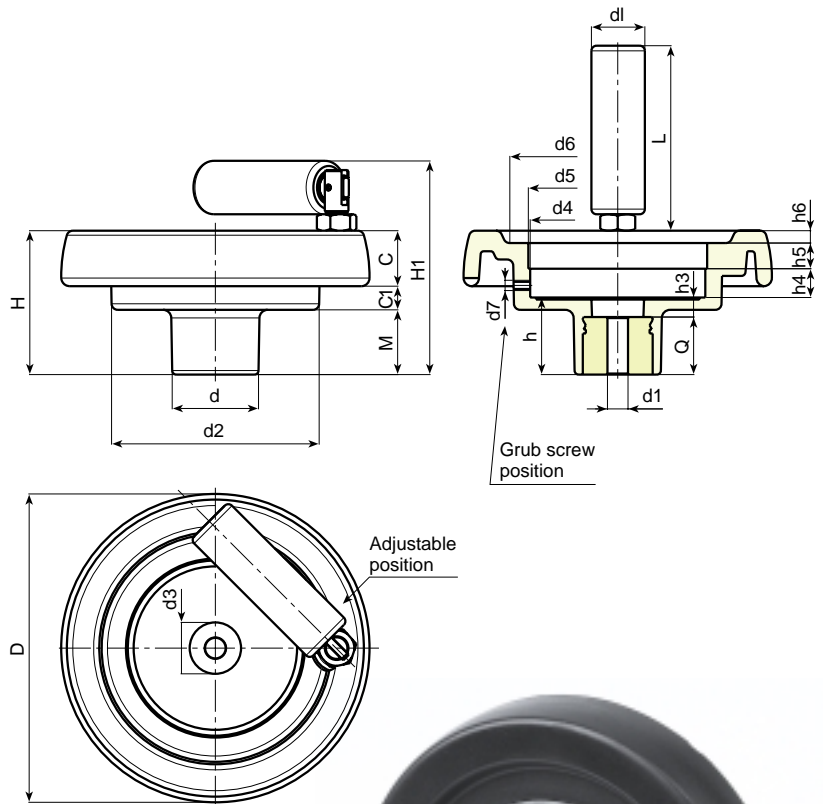

### SPECIAL REQUESTS:

- It is possible to supply the inserts with d1 diameter by customer design, on request and for quantities.
- It is possible to supply the inserts in different materials, on request and for quantities.
- It is possible to supply the inserts with different treatment-finishes, on request and for quantities.
- On request and for special quantities the indicator seat can be changed.
- It is possible to supply the complete handwheel with colours as shown in the table at page 15, on request and for quantities.

Art.	D	H	d	d2	M	C	C1	d3	d4	d5	d6	d7	h	h3	h4	h5	h6	d1 H7	dm	Q	d1	L	H1	Weight (gr)
K904-87 T50 D5.8	86	53	32	62	21	17	15	20	50,5	52 (S50/1)	63	M6	26,5	6,5	11,5	12	3	5,8 H9	12	20	20	56	77	194
K904-87 T50 D10	86	53	32	62	21	17	15	20	50,5	52 (S50/1)	63	M6	26,5	6,5	11,5	12	3	10	12	20	20	56	77	194
K904-100 T50 D6.8	99	55,5	32	63	23,5	20,5	11,5	20	50,5	52 (S50/1)	68	M6	29	9	11,5	12	3,5	6,8 H9	12	20	20	56	80	209
K904-100 T50 D10	99	55,5	32	63	23,5	20,5	11,5	20	50,5	52 (S50/1)	68	M6	29	9	11,5	12	3,5	10	12	20	20	56	80	209
K904-130 T80 D6.8	129	64,5	42	100	27,5	23	14	29	85,5	87 (S80/1)*	90	M6	34	10	13,5	12,5	5	6,8 H9	20	24	25	76	94	421
K904-130 T80 D12	129	64,5	42	100	27,5	23	14	29	85,5	87 (S80/1)*	90	M6	34	10	13,5	12,5	5	12	20	24	26	89	94	419
K904-150 T80 D6.8	149	69	42	101	31	25,5	12,5	29	85,5	87 (S80/1)*	106	M6	37	9	13,5	12,5	6,5	6,8 H9	20	28	26	89	104	582
K904-150 T80 D14	149	69	42	101	31	25,5	12,5	29	85,5	87 (S80/1)*	106	M6	37	9	13,5	12,5	6,5	14	20	28	26	89	104	579
K904-175 T80 D6.8	175	72	40	115	28,5	32	11,5	25	85,5	87 (S80/1)*	126,5	M6	38	10	12,5	14	8	6,8 H9	20	28	26	89	107	800
K904-175 T80 D16	175	72	40	115	28,5	32	11,5	25	85,5	87 (S80/1)*	126,5	M6	38	10	12,5	14	8	16	20	28	26	89	107	795
K904-200 T120 D6.8	199	71	46	137	24	32	15	29	124	125,5 (S120/1)+	144	M6	34	11	13,5	12,5	10	6,8 H9	22	23	26	97	106	970
K904-200 T120 D20	199	71	46	137	24	32	15	29	124	125,5 (S120/1)+	144	M6	34	11	13,5	12,5	10	20	22	23	26	97	106	964

It's possible to increase the hole, by boring, until dm.

Next to the d5 diameter is shown a mountable Siko indicator. For information on the indicator visit the SIKO web site at [www.siko.de](http://www.siko.de).

# ART. K905

## SOLID CONTROL HANDWHEEL FOR BUILT-IN POSITION INDICATOR WITH REVOLVING, FOLDING HANDLE AND LOCKING HANDWHEEL

### MATERIAL:

Reinforced and stabilised polyamide.  
Oils and greases resistant.

### SURFACE:

Satin.

### HANDWHEEL AND HANDLE COLOUR:

Black (RAL 9011).

### ATTACHABLE POSITION INDICATOR:

SIKO gravity indicator type "S" or "SZ". The indicator can only be used in a vertical position (horizontal machine axle). The indicator and the d7 grub screw must be purchased separately. For further details see page 12.

(\*) SIKO position indicator S50/1 can be mounted with adapter KS80-50.

(+) SIKO position indicator S80/1 can be mounted with adapter KS120-80.

### MAIN INSERT:

Zinc plated steel right through bored bush with H7 tolerance.

### SIDE INSERT:

Brass right through threaded bush.

### SIDE HANDLE:

Revolving handle and folding Art. M136 (see chapter M on page 10).

### LOCKING HANDWHEEL:

Cylindrical handwheel G793-36 with threaded stud (see chapter G page 12). Black (RAL 9011).

**Caution:** the Q2 dimension of the handwheel must be chosen by the customer according to the dimensions of the machinery on which it will be installed. For model K905-130 the locking handwheel is replaced with the wingnut L751-32 (see chapter L page 10).

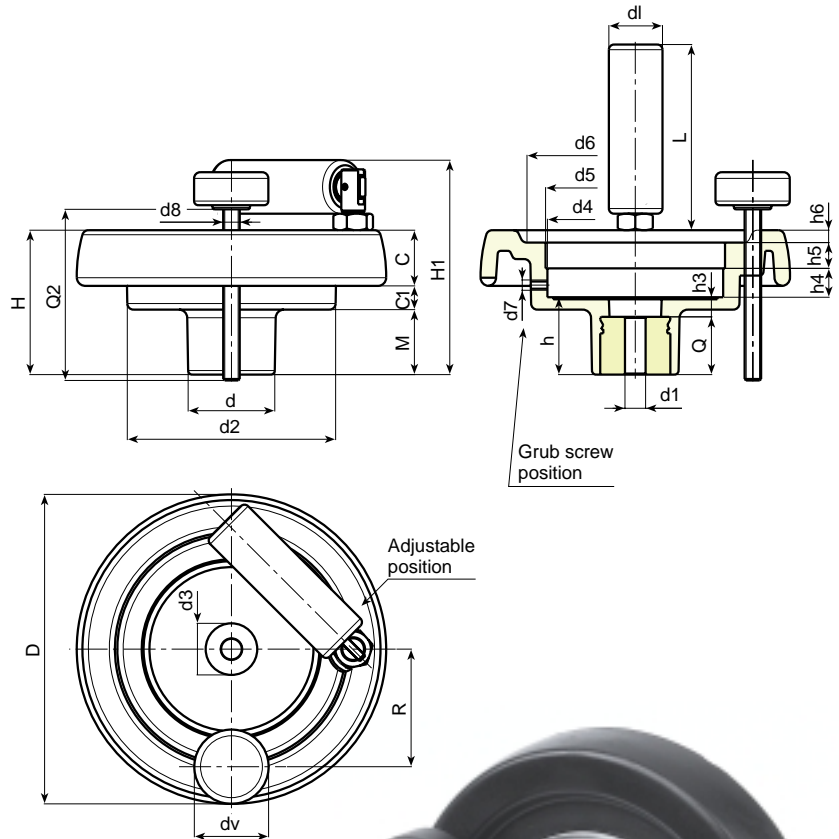

For fixing systems, or execution of tabs or square holes, please refer to the technical notes attached to the catalogue.

### SPECIAL REQUESTS:

- It is possible to supply the inserts with d1 diameter by customer design, on request and for quantities.
- It is possible to supply the inserts in different materials, on request and for quantities.
- It is possible to supply the inserts with different treatment-finishes, on request and for quantities.
- On request and for special quantities the indicator seat can be changed.
- It is possible to supply the complete handwheel with colours as shown in the table at page 15, on request and for quantities.

Art.	D	H	d	d2	M	C	C1	d3	d4	R	d5	d6	d8	d7	h	h3	h4	h5	h6	d1	H7	dm	Q	dl	L	H1	Weight (gr)
K905-130 T80 D5.8	129	64,5	42	100	27,5	23	14	29	85,5	54	87 (S80/1) *	90	M8	M6	34	10	13,5	12,5	5	6,8	H9	20	24	25	76	94	430
K905-130 T80 D12	129	64,5	42	100	27,5	23	14	29	85,5	54	87 (S80/1) *	90	M8	M6	34	10	13,5	12,5	5	12		20	24	25	76	94	427
K905-150 T80 D6.8	149	69	42	101	31	25,5	12,5	29	85,5	57	87 (S80/1) *	106	M8	M6	37	9	13,5	12,5	6,5	6,8	H9	20	28	26	89	104	615
K905-150 T80 D14	149	69	42	101	31	25,5	12,5	29	85,5	57	87 (S80/1) *	106	M8	M6	37	9	13,5	12,5	6,5	14		20	28	26	89	104	610
K905-175 T80 D6.8	175	72	40	115	28,5	32	11,5	25	85,5	60	87 (S80/1) *	126,5	M8	M6	38	10	12,5	14	8	6,8	H9	20	28	26	89	107	834
K905-175 T80 D16	175	72	40	115	28,5	32	11,5	25	85,5	60	87 (S80/1) *	126,5	M8	M6	38	10	12,5	14	8	16		20	28	26	89	107	829
K905-200 T120 D6.8	199	71	46	137	24	32	15	29	124	74	125,5 (S120/1) +	144	M8	M6	34	11	13,5	12,5	10	6,8	H9	22	23	26	97	106	1000
K905-200 T120 D20	199	71	46	137	24	32	15	29	124	74	125,5 (S120/1) +	144	M8	M6	34	11	13,5	12,5	10	20		22	23	26	97	106	993

Q2 = On request.

dv = 36 mm (K905-130 dv = 32 mm)..

It's possible to increase the hole, by boring, until dm.

Next to the d5 diameter is shown a mountable Siko indicator. For information on the indicator visit the SIKO web site at [www.siko.de](http://www.siko.de).

# ART. KS

## ADAPTER FOR POSITION INDICATOR SEAT

**MATERIAL:**

Reinforced and stabilised polyamide.  
Oils and greases resistant.

**SURFACE:**

Satin.

**COLOUR:**

Black (RAL 9011).

**ALTERNATIVE ADAPTOR COLOUR:**

Orange (RAL 2004 cod. 02).

Blue (RAL 5015 cod. 07).

Yellow (RAL 1021 cod.10).

Red (RAL 3000 cod.16).

Green (RAL 6024 cod.17).

Grey (RAL 7035 cod. 13).

**Caution:** Grub screw for indicator not supplied.

**SPECIAL REQUESTS:**

- It is possible to supply colours as shown in the table at page 15, on request and for quantities.

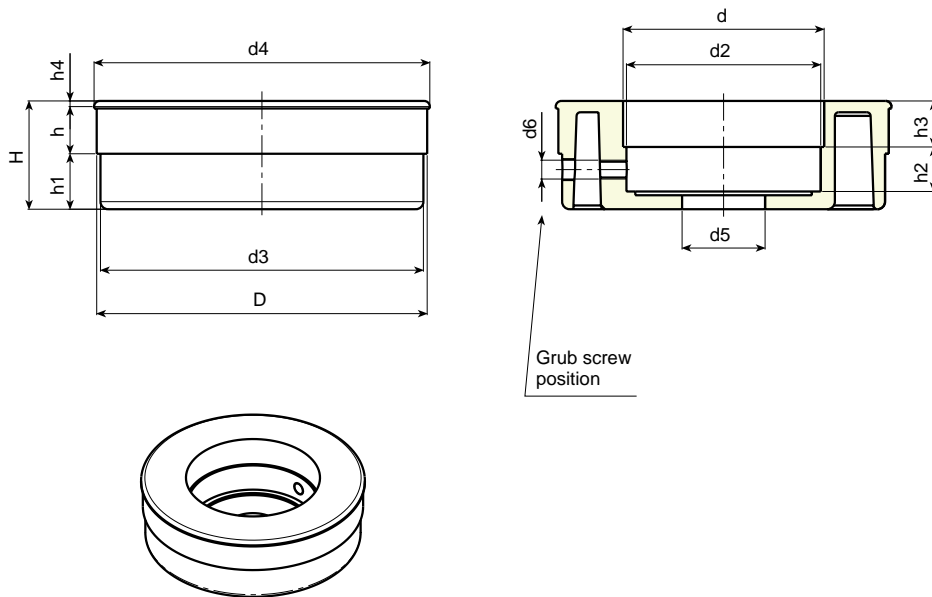

Art.	D	d	d2	d3	d4	d5	d6	H	h	h1	h2	h3	h4	Weight (gr)
KS080-50	86,8 (S80/1)	52 (S50/1)	51,5	85,5	89	22	M6	28,5	14	14,5	11,8	12,2	2	80
KS120-80	(S120/1)	Available from January 2005												



# ART. K500

## INDICATOR SEAT CLOSING COVERS

**MATERIAL:**

Reinforced and stabilised polyamide.  
Oils and greases resistant.

**SURFACE:**

Satin.

**PRIMARY COVER COLOUR:**

Black (RAL 9011).

**SECONDARY COVER COLOUR:**

Grey (RAL 7035 cod. 13).

**ALTERNATIVE CAP COLOUR:**

Orange (RAL 2004 cod. 02).  
Blue (RAL 5015 cod. 07).  
Yellow (RAL 1021 cod.10).  
Red (RAL 3000 cod.16).  
Green (RAL 6024 cod.17).  
Black (RAL 9011 cod. 01).

**COVER FIXING METHOD:**

Self push-fit. Removable.

**SPECIAL REQUESTS:**

- It is possible to supply colours as shown in the table at page 15, on request and for quantities.

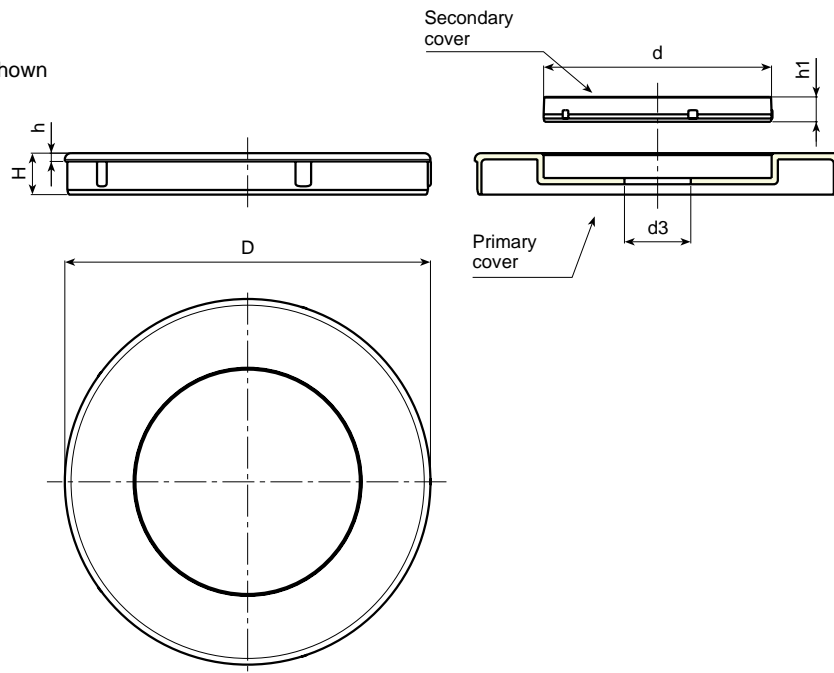
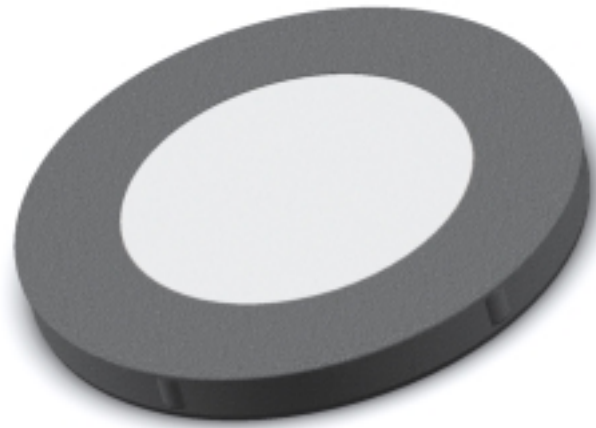

**PAD PRINTING SERVICE:**

- Upon request and for special quantities caps can be supplied with customized pad printing.

Art.	D	d	d3	H	h	h1	Weight (gr)
K500-50	51,8 (S50/1)	34	10	8	2	5	10
K500-80	86,8 (S80/1)	55	16	10	2	6	25
K500-120	(S120/1)	Available from January 2005					

# INDICATORS

BOTECO handwheels with SIKO position indicators are used in the most varied industrial applications. The reliable, precise operating principle of these instruments make them suitable for use in printing machines, in the food industry, as well as in the standard applications of the sheet metal and wood industries. They are robust enough to guarantee maximum durability even in the toughest working environments. The sturdy operating principle of the position indicators combined with tangible ergonomics make the BOTECO +SIKO handwheels extremely reliable.

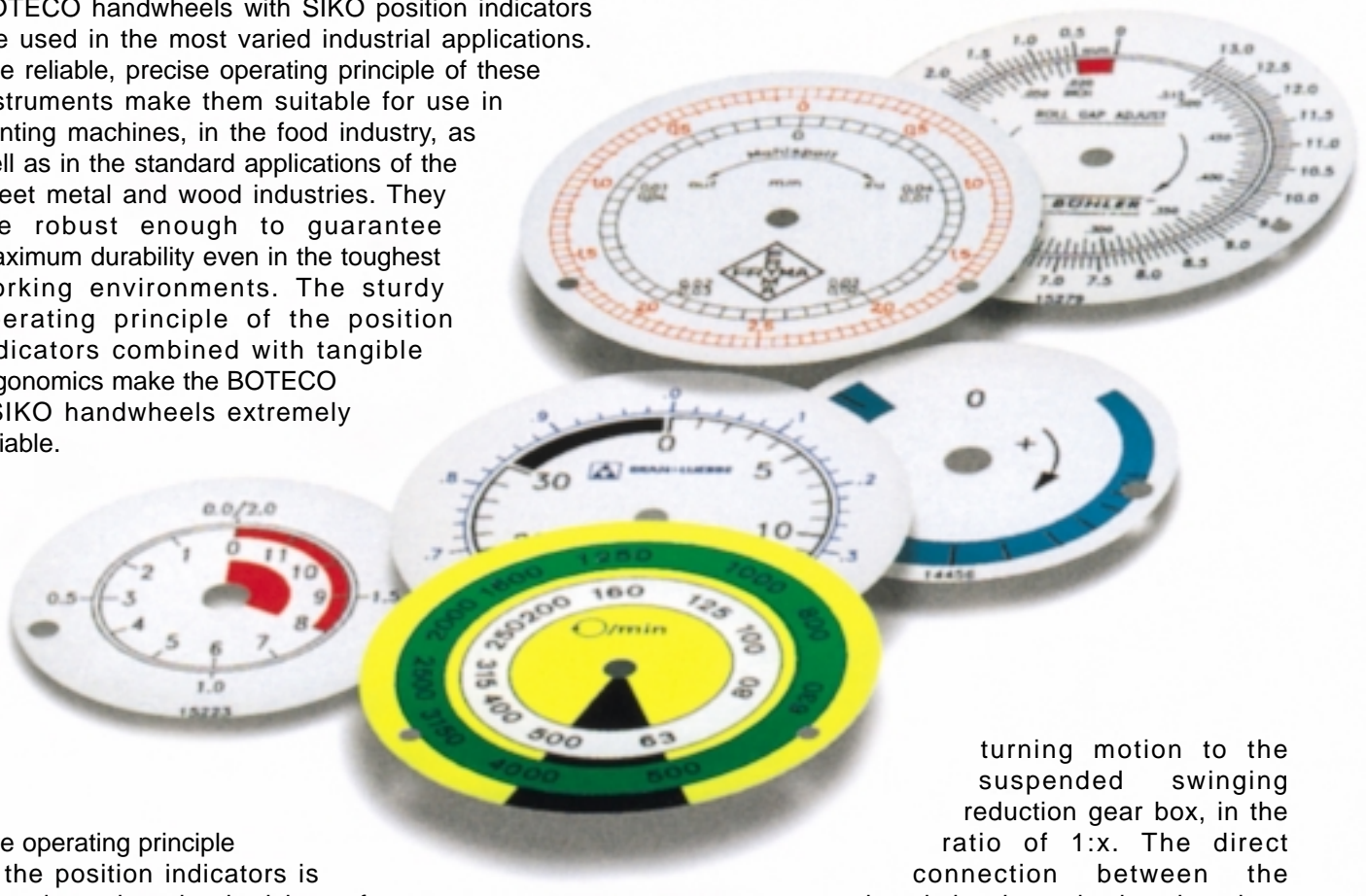

The operating principle of the position indicators is based on the physical law of gravity. The suspension design in the housing makes it possible to have a double bearing-supported pointer shaft that is formed as a suspension axle for a freely swinging weight. The scale, the gearbox with the required gear ratio and the pointer bushing orient themselves to the weight alignment. When the handwheel is turned, the gear that is attached to the pointer shaft transmits the

turning motion to the suspended swinging reduction gear box, in the ratio of 1:x. The direct connection between the handwheel and the bearing-supported gearbox makes it possible to obtain 100% accurate values.

Handwheels used on horizontal spindles have a reliable, maintenance-free construction. They make it possible to achieve accurate adjustment and reading of even the finest rotational settings, independent of the pitch of the spindle to be measured.



**Information to be given when placing an order or requesting a quotation**

In order to choose the most suitable indicator the following information must be provided when placing an order or requesting a quotation:

- d1:** Diameter of the handwheel bore, where it is joined to the shaft.
- P:** Pitch of the shaft where the handwheel with indicator is joined to it. The pitch is the distance the shaft moves with one revolution of the handwheel.
- Direction:** Rotation of the pointers, clockwise or counterclockwise.
- d5:** Diameter of the indicator to be used.
- Configuration:** N – Dust-tight configuration (standard).  
P – Filled with paraffin oil. Absorbs vibrations and shock. Condensation-free.  
W – Water-tight.

**Scale and accuracy of the indication.** As these are the most important data, their selection must be made very carefully.

Each scale and each divisioning for the position indicator must satisfy various requirements. The basis for the indicated values is always formed by the selected gear ratio. This defines the distance that should be travelled for a certain number of revolutions. The S-type position indicator can be configured with two pointers where one pointer is always moved with a gear ratio. With only one pointer and an assumed gear ratio of 20, a geared pointer moves through a scale range of 360° for 20 handwheel revolutions, that is, the complete adjustment distance must be within only one revolution of this pointer. With the selection of a

second pointer, it moves 1:1 with the actual movement of the handwheel.

The SZ-type position indicator is designed for large measuring distances. In this model, the geared pointer of the S-type is replaced with a digital counter. This makes it possible to display more than one revolution of the reduced pointer. This combination has proven to be particularly useful in applications which require a large number of revolutions and precise position information.

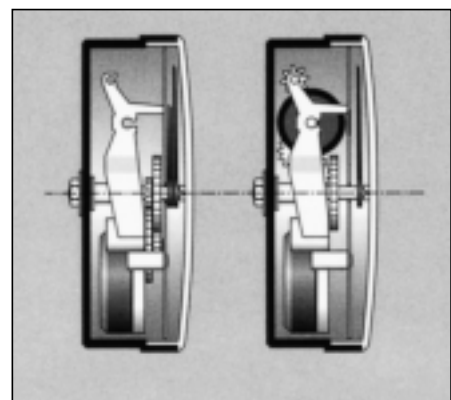









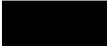

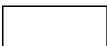



Naturally, the standard scales cannot satisfy all needs. Therefore, SIKO provides special scales constructed according to customer requirements, such as for example, to indicate adjustments in both directions that start from a zero value and require a scale with increasing and decreasing values. For the fabrication of such scales, precise information in the form of sketches or technical drawings must be provided by the customer. We will also gladly comply with special customer requirements such as for example division marks, numbers, company logos or special colours.





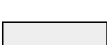









# COLOUR CHART

## R A L

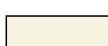
COLOUR		RAL	CODE
Black		9011	01
Orange		2004	02
Orange		2011	03
White		9010	04
Blue		5002	05
Blue		5005	06
Blue		5015	07
Blue		5018	19
Blue		5019	21
Blue		5010	22
Yellow		1007	09
Yellow		1021	10
Grey		7024	12
Grey		7035	13
Red		3000	16
Green		6024	17

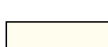
## O T H E R C O L O U R S

COLOUR		REF.	CODE
White		-	52
Blue		-	53
Blue		pant. 645 U	54
Blue		pant. 300	55
Grey		-	57
Grey		-	59
Grey		NCS 7500	60
Red		-	64
Red		-	65
Natural		-	66
Green		-	70
Brown		-	71
Cream		-	72
Violet		-	73