

# Support Unit of Ball Screw

---

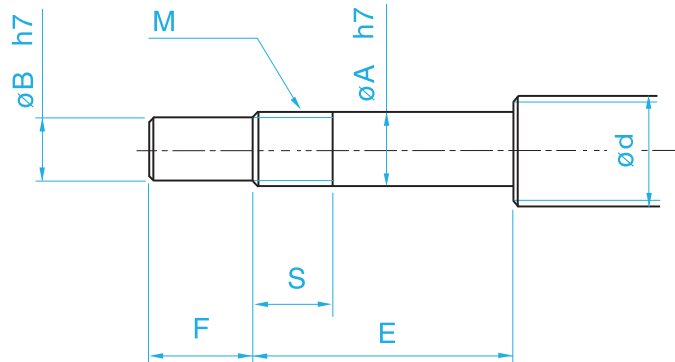

## Recommended Shaft End Shape For Support Unit Type BK and FK and EK Fixed Side



Unit:mm

Support Unit model No.	Ball Screw shaft OD	Shaft Support Portion OD				Metric screw thread	
Type BK	d	A	B	E	F	M	S
BK 10	12/14/15	10	8	36	15	M10X1	16
BK 12	14/15/16	12	10	36	15	M12X1	14
BK 15	18/20	15	12	40	20	M15X1	12
BK 17	20/25	17	15	53	23	M17X1	17
BK 20	25/28	20	17	53	25	M20X1	15
BK 25	32/36	25	20	65	30	M25X1.5	18
BK 30	36/40	30	25	72	38	M30X1.5	25
BK 35	45	35	30	81	45	M35X1.5	28
BK 40	50	40	35	93	50	M40X1.5	35

Unit:mm

Support Unit model No.		Ball Screw shaft OD	Shaft Support Portion OD				Metric screw thread	
Type FK	Type EK	d	A	B	E	F	M	S
FK 6	EK 6	8	6	4	28	8	M6X0.75	8
FK 8	EK 8	10/12	8	6	32	9	M8X1	10
FK 10	EK 10	12/14/15	10	8	36	15	M10X1	11
FK 12	EK 12	14/15/16	12	10	36	15	M12X1	11
FK 15	EK 15	18/20	15	12	47	20	M15X1	13
FK 20	EK 20	25/28/30	20	17	62	25	M20X1	17
FK 25	–	30/32/36	25	20	76	30	M25X1.5	20
FK 30	–	36/40	30	25	72	38	M30X1.5	25

# Recommended Shaft End Shape For Support Unit Types FF and EF and BF Floated Side

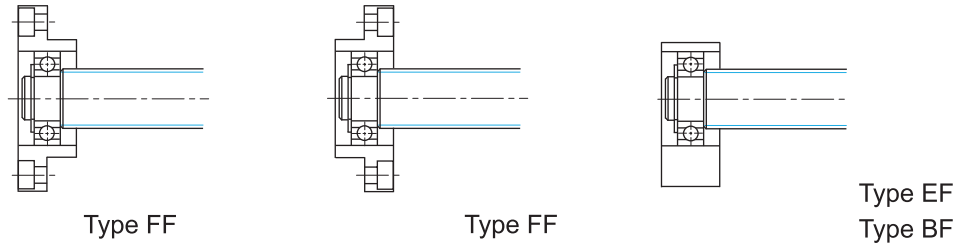

Unit:mm

Support Unit model No.			Ball Screw shaft OD	Shaft Support Portion OD
Type FF	Type EF	Type BF	d	A
FF 10	EF 10	BF 10	12/14/15	8
FF 12	EF 12	BF 12	14/15/16	10
FF 15	EF 15	BF 15	18/20	15
FF 17	—	BF 17	20/25	17
FF 20	EF 20	BF20 (NOTE)	25/28/30	20
FF 25	—	BF 25	30/32/36	25
FF 30	—	BF 30	36/40	30
—	—	BF 35	40/45	35
—	—	BF 40	50	40

Support Unit of Ball Screw

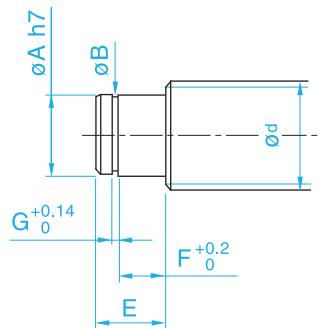

Note:

In this table, dimensions in parentheses are those of type BF20. These dimensions differ from those of type FF20 and EF20. When placing an order, always specify the model number of the Support Unit to be used.

Unit:mm

E	Snap-ring Groove		
	B	F	G
10	7.6	7	0.9
11	9.6	8	1.15
13	14.3	9	1.15
16	16.2	12	1.15
19(16)	19	14(12)	1.35
20	23.9	15	1.35
21	28.6	16	1.75
22	33	17	1.75
23	38	18	1.75

# FK

## Fixed Side

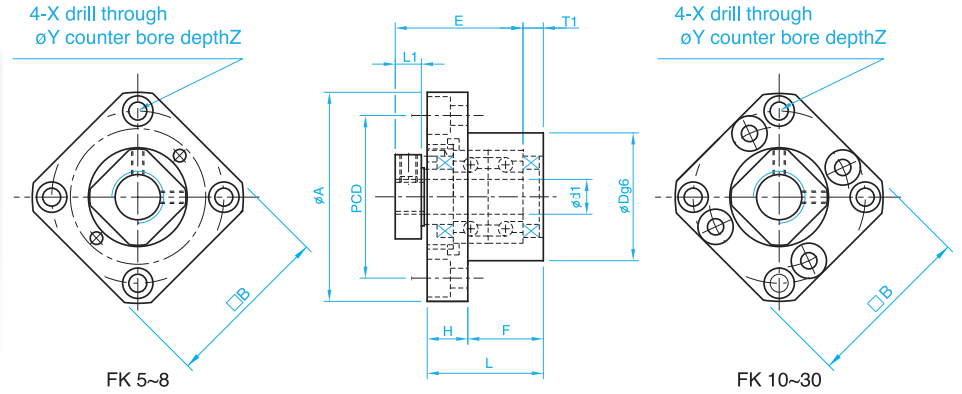

Unit : mm

Model No.	d1	L	H	F	E	Dg6	A	PCD	B	L1	T1	X	Y	Z
FK 5	5	16.5	6	10.5	18.5	20	34	26	26	5.5	3.5	3.4	6.5	4
FK 6	6	20	7	13	22	22	36	28	28	5.5	3.5	3.4	6.5	4
FK 8	8	23	9	14	26	28	43	35	35	7	4	3.4	6.5	4
FK 10	10	27	10	17	29.5	34	52	42	42	7.5	5	4.5	8	4
FK 12	12	27	10	17	29.5	36	54	44	44	7.5	5	4.5	8	4
FK 15	15	32	15	17	36	40	63	50	52	10	6	5.5	9.5	6
FK 20	20	52	22	30	50	57	85	70	68	8	10	6.6	11	10
FK 25	25	57	27	30	60	63	98	80	79	13	10	9	15	13
FK 30	30	62	30	32	61	75	117	95	93	11	12	11	17.5	15

# FF

## Floated Side

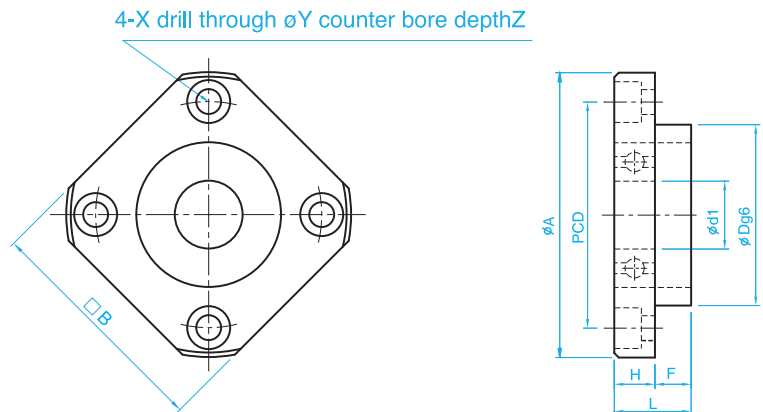

Unit : mm

Model No.	d1	L	H	F	Dg6	A	PCD	B	X	Y	Z
FF 6	6	10	6	4	22	36	28	28	3.4	6.5	4
FF 10	8	12	7	5	28	43	35	35	3.4	6.5	4
FF 12	10	15	7	8	34	52	42	42	4.5	8	4
FF 15	15	17	9	8	40	63	50	52	5.5	9.5	5.5
FF 20	20	20	11	9	57	85	70	68	6.6	11	6.5
FF 25	25	24	14	10	63	98	80	79	9	14	8.5
FF 30	30	27	18	9	75	117	95	93	11	17.5	11

# BK

## Fixed Side

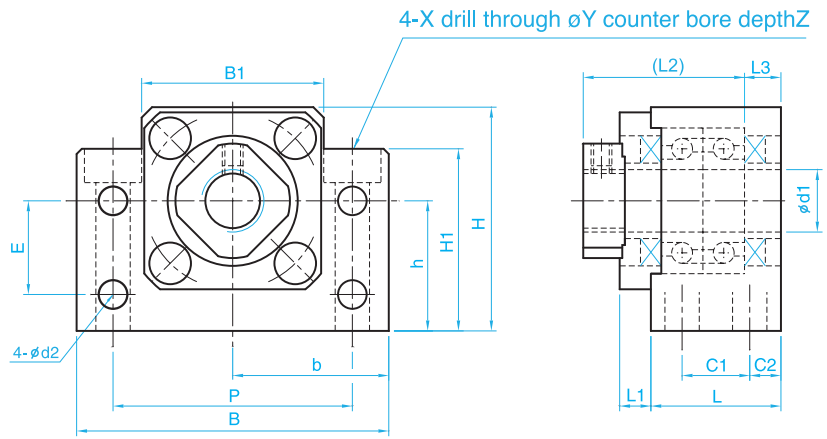

Unit : mm

Model No.	d1	L	L1	L2	L3	C1	C2	B	H	b <sup>±0.02</sup>	h <sup>±0.02</sup>	B1	H1	E	P	d2	X	Y	Z
BK 10	10	25	5	29	5	13	6	60	39	30	22	34	32.5	15	46	5.5	6.6	10.8	5
BK 12	12	25	5	29	5	13	6	60	43	30	25	34	32.5	18	46	5.5	6.6	10.8	1.5
BK 15	15	27	6	32	6	15	6	70	48	35	28	40	38	18	54	5.5	6.6	11	6.5
BK 17	17	35	9	44	7	19	8	86	64	43	39	50	55	28	68	6.6	9	14	8.5
BK 20	20	35	8	43	8	19	8	88	60	44	34	52	50	22	70	6.6	9	14	8.5
BK 25	25	42	12	54	9	22	10	106	80	53	48	64	70	33	85	9	11	17.5	11
BK 30	30	45	14	61	9	23	11	128	89	64	51	76	78	33	102	11	14	20	13
BK 35	35	50	14	67	12	26	12	140	96	70	52	88	79	35	114	11	14	20	13
BK 40	40	61	18	76	15	33	14	160	110	80	60	100	90	37	130	14	18	26	17.5

# BF

## Floated Side

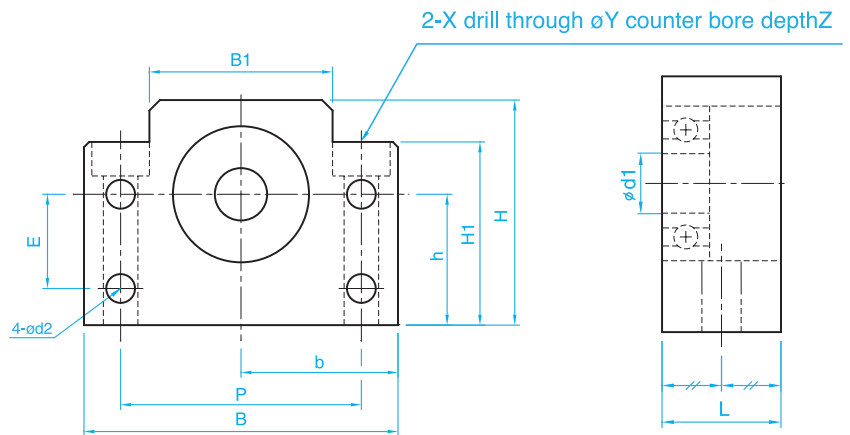

Unit : mm

Model No.	d1	L	B	H	b <sup>±0.02</sup>	h <sup>±0.02</sup>	B1	H1	E	P	d2	X	Y	Z
BF 10	8	20	60	39	30	22	34	32.5	15	46	5.5	6.6	10.8	5
BF 12	10	20	60	43	30	25	34	32.5	18	46	5.5	6.6	10.8	1.5
BF 15	15	20	70	48	35	28	40	38	18	54	5.5	6.6	11	6.5
BF 17	17	23	86	64	43	39	50	55	28	68	6.6	9	14	8.5
BF 20	20	26	88	60	44	34	52	50	22	70	6.6	9	14	8.5
BF 25	25	30	106	80	53	48	64	70	33	85	9	11	17.5	11
BF 30	30	32	128	89	64	51	76	78	33	102	11	14	20	13
BF 35	35	32	140	96	70	52	88	79	35	114	11	14	20	13
BF 40	40	37	160	110	80	60	100	90	37	130	14	18	26	17.5

# EK

## Fixed Side

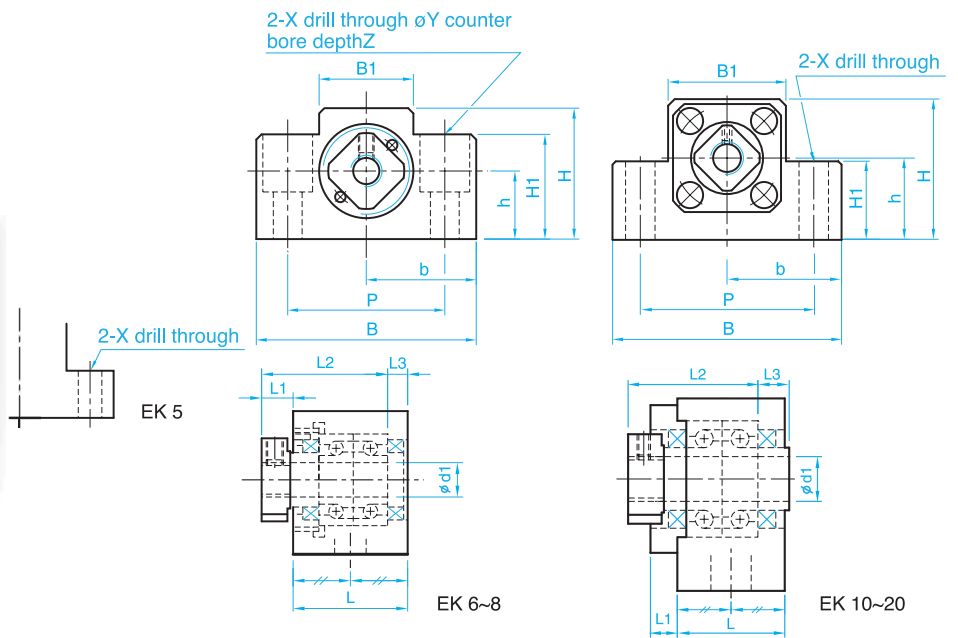

Unit : mm

Model No.	d1	L	L1	L2	L3	B	H	b <sup>±0.02</sup>	h <sup>±0.02</sup>	B1	H1	P	X	Y	Z
EK 5	5	16.5	5.5	18.5	3.5	36	21	18	11	20	8	28	4.5	—	—
EK 6	6	20	5.5	22	3.5	42	25	21	13	18	20	30	5.5	9.5	11
EK 8	8	23	7	26	4	52	32	26	17	25	26	38	6.6	11	12
EK 10	10	24	6	29.5	6	70	43	35	25	36	24	52	9	—	—
EK 12	12	24	6	29.5	6	70	43	35	25	36	24	52	9	—	—
EK 15	15	25	6	36	5	80	49	40	30	41	25	60	11	—	—
EK 20	20	42	10	50	10	95	58	47.5	30	56	25	75	11	—	—

# EF

## Floated Side

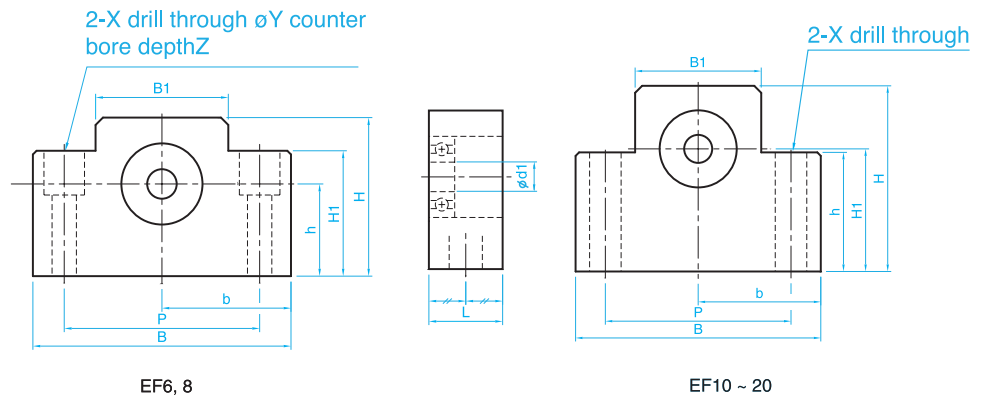
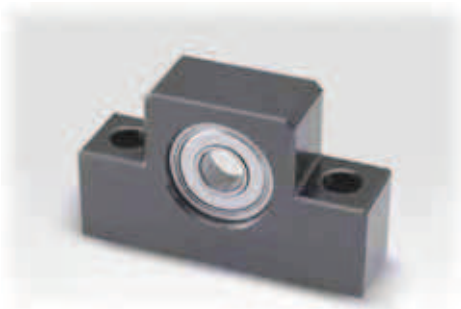

Unit : mm

Model No.	d1	L	B	H	b <sup>±0.02</sup>	h <sup>±0.02</sup>	B1	H1	P	X	Y	Z
EF 6	6	12	42	25	21	13	18	20	30	5.5	9.5	11
EF 8	6	14	52	32	26	17	25	26	38	6.6	11	12
EF 10	8	20	70	43	35	25	36	24	52	9	—	—
EF 12	10	20	70	43	35	25	36	24	52	9	—	—
EF 15	15	20	80	49	40	30	41	25	60	9	—	—
EF 20	20	26	95	58	47.5	30	56	25	75	11	—	—