

815

Catena rettilinea
Straight running chain / Geradegängige Scharnierbandkette

Pins: Martensitic 1.4057 | Backflex radius min.: 150 mm

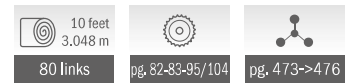
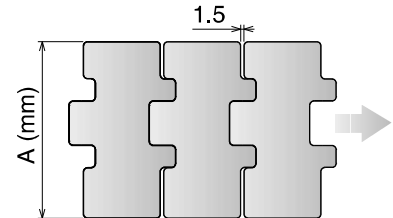
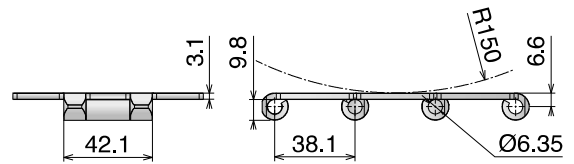

Article-Nr.	Ref.	A (Plate Width) mm	Weight kg/m	Surface finish μm	Surface Flatness mm	Polished Hinge eyes	Max working load (N)	Plate Thickness mm
SSM Max Speed - Hardened pins								
10010302	SSM 815 K325	82,5	2,55	0,2	0,08	YES	6000	3,1
10010303	SSM 815 K330	83,8	2,59	0,2	0,08	YES		

Max Speed High Performance

- Improved working load
- Minimum possible gap
- Optimum plate & hinge flatness
- Link with improved chamfer
- Total quality control
- Hardened pins
- Calibrated pin and hinge
- Polished hinges

812/815

Catena rettilinea
Straight running chain / Geradegängige Scharnierbandkette

Pins: Martensitic 1.4057 | Backflex radius min.: 150 mm

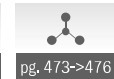
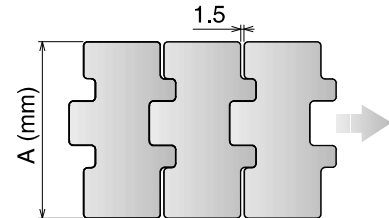
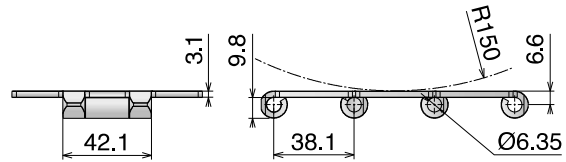

Article-Nr.	Ref.	A (Plate Width) mm	Weight kg/m	Surface finish µm	Surface Flatness mm	Polished Hinge eyes	Max working load (N)	Plate Thickness mm
-------------	------	--------------------	-------------	-------------------	---------------------	---------------------	----------------------	--------------------

SS Ferritic Stainless Steel (1.4016)

10010216	SS 812 K300	76,2	2,50	0,5	0,15	NO	5400	3,1
10010202	SS 812 K325	82,5	2,55	0,5	0,15	NO		
10010203	SS 812 K330	83,8	2,59	0,5	0,15	NO		
10010204	SS 812 K350	88,9	2,69	0,5	0,15	NO		
10010214	SS 812 K400	101,6	3,00	0,5	0,15	NO		
10010205	SS 812 K450	114,3	3,25	0,5	0,20	NO		
10010206	SS 812 K600	152,4	4,15	0,5	0,30	NO		
10010207	SS 812 K750	190,5	5,05	0,5	0,30	NO		

SSE Specially treated Ferritic Stainless Steel (1.4589) - Hardened pins

10010102	SSE 815 K325	82,5	2,55	0,3	0,10	YES	6000	3,1
10010103	SSE 815 K330	83,8	2,59	0,3	0,10	YES		
10010104	SSE 815 K350	88,9	2,69	0,3	0,15	NO		
10010114	SSE 815 K400	101,6	3,00	0,3	0,15	NO		
10010105	SSE 815 K450	114,3	3,25	0,3	0,20	NO		
10010106	SSE 815 K600	152,4	4,15	0,3	0,30	NO		
10010107	SSE 815 K750	190,5	5,05	0,3	0,30	NO		

SSA Austenitic Stainless Steel (AISI 304) - Austenitic pin

10010402	SSA 815 K325	82,5	2,55	0,5	0,15	NO	5300	3,1
10010403	SSA 815 K330	83,8	2,59	0,5	0,15	NO		
10010404	SSA 815 K350	88,9	2,69	0,5	0,15	NO		
10010405	SSA 815 K450	114,3	3,25	0,5	0,20	NO		
10010406	SSA 815 K600	152,4	4,15	0,5	0,30	NO		
10010407	SSA 815 K750	190,5	5,05	0,5	0,30	NO		

812 GT/815 GT

Catene in acciaio / Steel chains / Scharnierbandketten aus Edelstahl

812 GT/815 GT

Catena rettilinea
Straight running chain / Geradegängige Scharnierbandkette

Pins: Martensitic 1.4057

Backflex radius min.: 75 mm

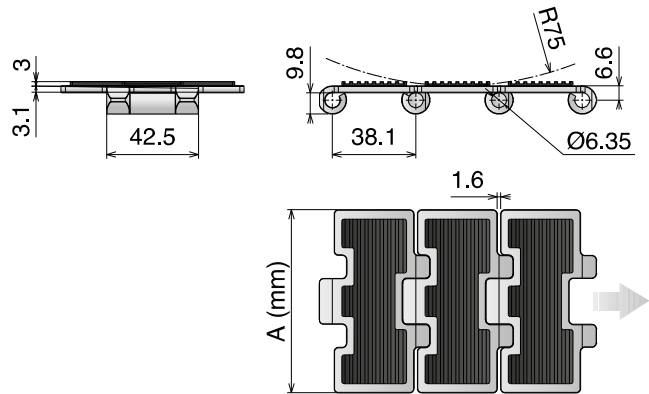

80 links



pg. 82-83-95/104



pg. 473->476

Article-Nr.	Ref.	A (Plate Width) mm	Weight kg/m	Max working load (N)	Plate/Rubber Thickness mm
SS Ferritic Stainless Steel (1.4016)					
10020202	SS 812 GT K325	82,5	2,80	5400	Plate 3,1 Rubber 3
SSE Specially treated Ferritic Stainless Steel (1.4589) - Hardened pins					
10020102	SSE 815 GT K325	82,5	2,80	6000	Plate 3,1 Rubber 3
10020105	SSE 815 GT K450	114,3	3,55		
10020107	SSE 815 GT K750	190,5	5,55		

815 TAB GT

Catena rettilinea
Straight running chain / Geradegängige Scharnierbandkette

Pins: Martensitic 1.4057

Backflex radius min.: 75 mm

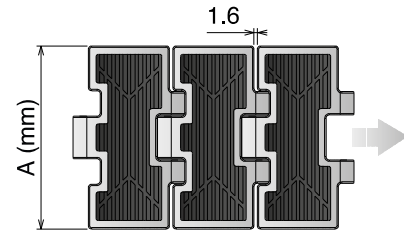
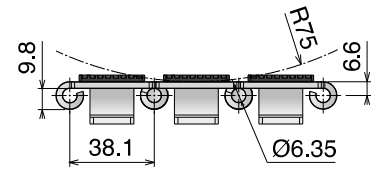
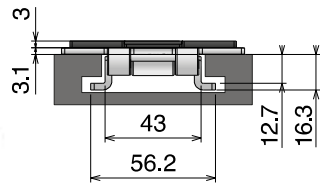

Tab System



80 links



pg. 82-83-95/104



pg. 473->476

Article-Nr.	Ref.	A (Plate Width) mm	Weight kg/m	Max working load (N)	Plate/Rubber Thickness mm
SSE Specially treated Ferritic Stainless Steel (1.4589) - Hardened pins					
10200102	SSE 815 TAB GT K325	82,5	3,40	6000	Plate 3,1 Rubber 3

815

Ruota traino divisa, fresata

Split drive sprocket, machined / geteiltes Antriebskettenrad gefräst

Used also for Series 881 M

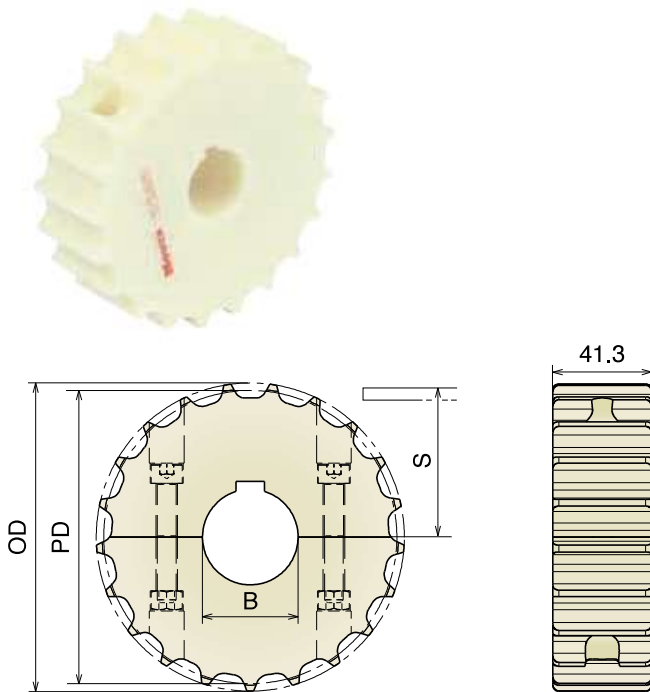

Part	Article-Nr.	Z-	Bore	PD	OD	S
501	50101	17	25	105,5	103,9	55,9
501	50102		30			
501	50103		35			
501	50104		40			
502	50201	19	25	117,3	117,0	61,9
502	50202		30			
502	50203		35			
502	50204		40			
503	50301	21	25	129,3	129,0	67,8
503	50302		30			
503	50303		35			
503	50304		40			
504	50401	23	25	141,2	142,0	73,8
504	50402		30			
504	50403		35			
504	50404		40			
505	50501	25	25	153,2	154,0	79,8
505	50502		30			
505	50503		35			
505	50504		40			
506	50601	27	25	165,2	166,8	85,8
506	50602		30			
506	50603		35			
506	50604		40			
507	50701	29	25	177,2	178,5	91,8
507	50702		30			
507	50703		35			
507	50704		40			

Ruota rinvio divisa, fresata

Split idler sprocket, machined / geteiltes Umlenkrad, gefräst

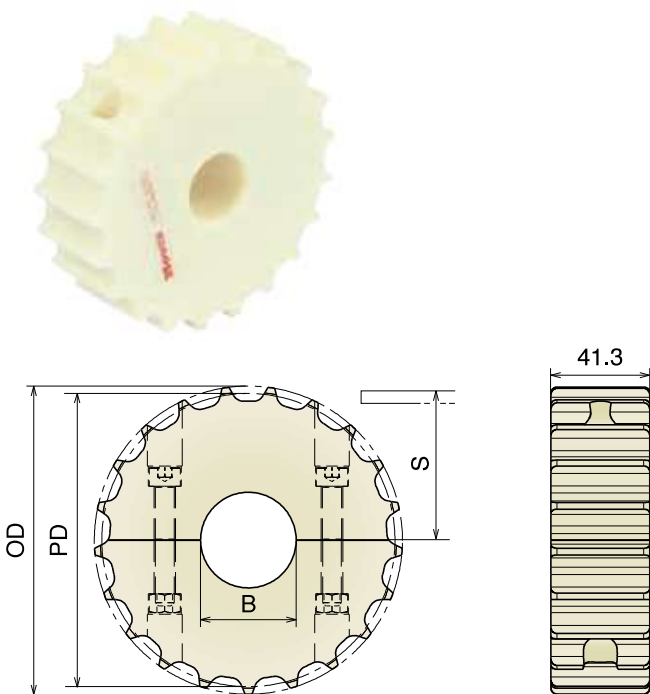

Part	Article-Nr.	Z-	Bore	PD	OD	S
501	50150	17	18*	105,5	103,9	55,9
501	50151		25			
501	50152		30			
501	50153		35			
501	50154		40			
502	50250	19	18*	117,3	117,0	61,9
502	50251		25			
502	50252		30			
502	50253		35			
502	50254		40			
503	50350	21	18*	129,3	129,0	67,8
503	50351		25			
503	50352		30			
503	50353		35			
503	50354		40			
504	50450	23	18*	141,2	142,0	73,8
504	50451		25			
504	50452		30			
504	50453		35			
504	50454		40			
505	50550	25	18*	153,2	154,0	79,8
505	50551		25			
505	50552		30			
505	50553		35			
505	50554		40			
506	50650	27	18*	165,2	166,8	85,8
506	50651		25			
506	50652		30			
506	50653		35			
506	50654		40			
507	50750	29	18*	177,2	178,5	91,8
507	50751		25			
507	50752		30			
507	50753		35			
507	50754		40			

*Plain Bore

Materiale / Material / Materialien:

Poliamide rinforzato / Polyamide reinforced / Verstärktes Polyamid

Viti: Acciaio inox / Screws: Stainless steel / Schrauben: Edelstahl

Dadi: Ottone nichelato / Nuts: Nickel plated brass / Mutter: Messing

815

Ruota traino divisa, stampata

Split drive sprocket, molded / geteiltes Antriebskettenrad, gespritzt

Used also for Series 881 M

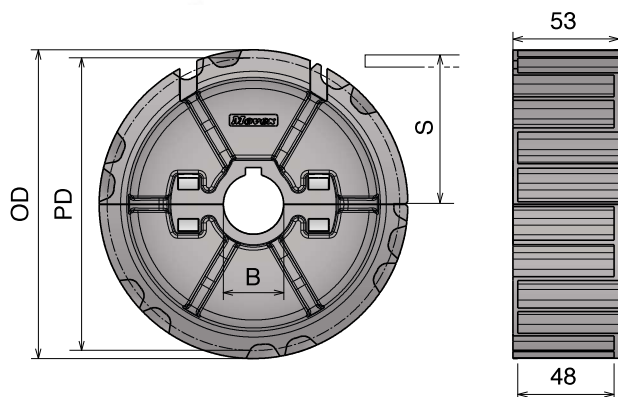

Part	Article-Nr.	Z-	Bore	PD	OD	S
508	50801	21	25	129,3	129,0	67,8
508	50802		30			
508	50803		35			
508	50804		40			
509	50901	23	25	141,2	142,0	73,8
509	50902		30			
509	50903		35			
509	50904		40			
510	51001	25	25	153,2	154,0	79,8
510	51002		30			
510	51003		35			
510	51004		40			

Improved Design and Performance

Ruota rinvio divisa, stampata

Split idler sprocket, molded / geteiltes Umlenkrad, gespritzt

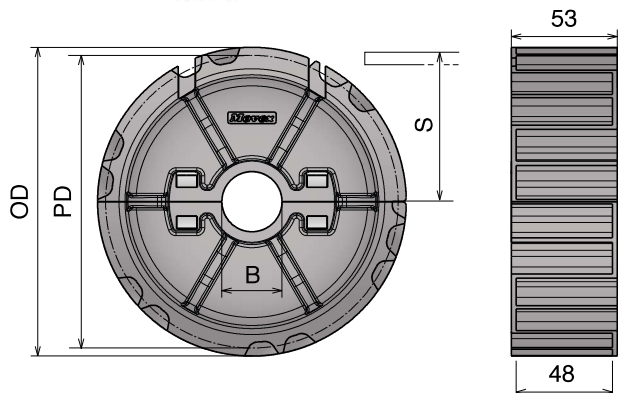

Part	Article-Nr.	Z-	Bore	PD	OD	S
508	50851	21	25	129,3	129,0	67,8
508	50852		30			
508	50853		35			
508	50854		40			
509	50951	23	25	141,2	142,0	73,8
509	50952		30			
509	50953		35			
509	50954		40			
510	51051	25	25	153,2	154,0	79,8
510	51052		30			
510	51053		35			
510	51054		40			

Improved Design and Performance

⚙️ **Materiale / Material / Materialien:**
 Poliammide/Polyamide/Polyamid
 Viti: Acciaio inox/Screws: Stainless steel/Schrauben: Edelstahl
 Dadi: ferro zincato/Nuts: zinc plated steel/Mutter: verzinkter Stahl

815-8157

Ruote dentate per catene / Chain sprockets / Kettenräder für Scharnierbandketten

815 Ruota flangiata divisa, fresata Split sprocket with guides, machined / Geteiltes Kettenrad mit Bordscheibe, gefräst

Anelli Inox / SS Guide-rings / Edelstahl Bordscheibe		Part	Article-Nr.	Z-	Bore	PD	OD	S	Ø screw
	503	50301G	21	25	129,3	129,0	67,8	104,0	
	503	50302G		30					
	503	50303G		35					
	503	50304G		40					
	504	50401G	23	25	141,2	142,0	73,8	116,0	
	504	50402G		30					
	504	50403G		35					
	504	50404G		40					
	505	50501G	25	25	153,2	154,0	79,8	128,0	
	505	50502G		30					
	505	50503G		35					
	505	50504G		40					

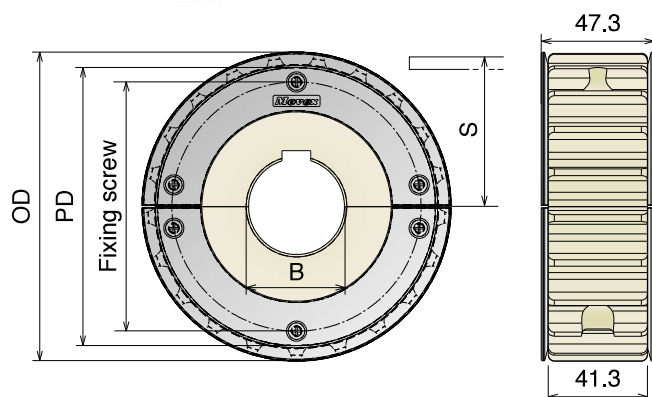

8157 Ruota flangiata divisa, fresata Split sprocket with guides, machined / Geteiltes Kettenrad mit Bordscheibe, gefräst

Anelli Inox / SS Guide-rings / Edelstahl Bordscheibe		Part	Article-Nr.	Z-	Bore	PD	OD	S	Ø screw
	530	53001G	21	25	129,3	129,0	67,8	104,0	
	530	53002G		30					
	530	53003G		35					
	530	53004G		40					
	531	53101G	23	25	141,2	142,0	73,8	116,0	
	531	53102G		30					
	531	53103G		35					
	531	53104G		40					
	532	53201G	25	25	153,2	154,0	79,8	128,0	
	532	53202G		30					
	532	53203G		35					
	532	53204G		40					

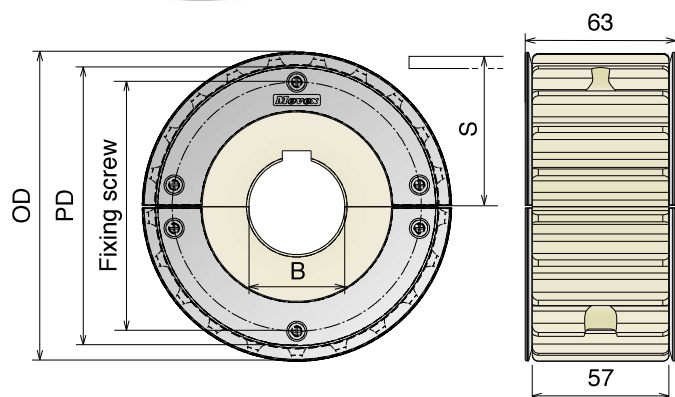

Ruote dentate per catene / Chain sprockets / Kettenräder für Scharnierbandketten

Materiale / Material / Materialien:

Poliammide/Polyamide/Polyamid

Viti: Acciaio inox/Screws: Stainless steel/Schrauben: Edelstahl

Dadi: ferro zincato/Nuts: zinc plated steel/Mutter: verzinkter Stahl

Dadi: ottone nichelato per stampate/Nuts: nickel plated brass for molded/Mutter: Messing vernickelt für gespritzt Version

815 Ruota rinvio liscia, divisa, fresata Split idler wheel, machined / geteilte Umlenkrolle, gefräst

Also suitable for Series 881 M - 820 - 831 - 828 - 879 M - 880 M

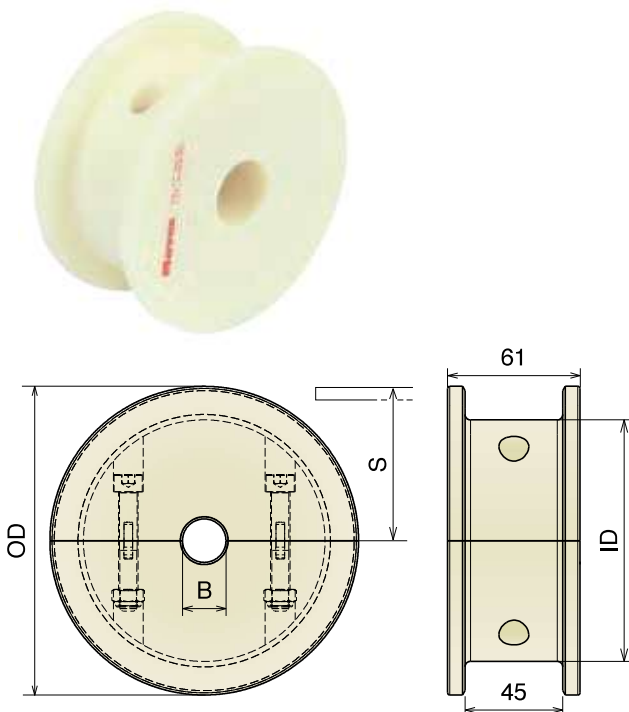

Part	Article-Nr.	ecq. Z-	Bore	OD	ID	S
601	60100	17	20	104,0	75,2	56,2
601	60101		25			
601	60102		30			
601	60103		35			
601	60104		40			
602	60200	19	20	117,0	92,2	62,6
602	60201		25			
602	60202		30			
602	60203		35			
602	60204		40			
603	60300	21	20	129,8	105,0	68,6
603	60301		25			
603	60302		30			
603	60303		35			
603	60304		40			
604	60400	23	20	142,2	111,3	74,6
604	60401		25			
604	60402		30			
604	60403		35			
604	60404		40			
605	60500	25	20	154,7	124,7	80,5
605	60501		25			
605	60502		30			
605	60503		35			
605	60504		40			
606	60600	27	20	167,2	135,0	88,5
606	60601		25			
606	60602		30			
606	60603		35			
606	60604		40			
607	60700	29	20	179,3	140,0	92,8
607	60701		25			
607	60702		30			
607	60703		35			
607	60704		40			

815 Ruota rinvio liscia, divisa, stampata Split idler wheel, molded / geteilte Umlenkrolle, gespritzt

Also suitable for Series 881 M - 820 - 831 - 828 - 879 M - 880 - 880 M

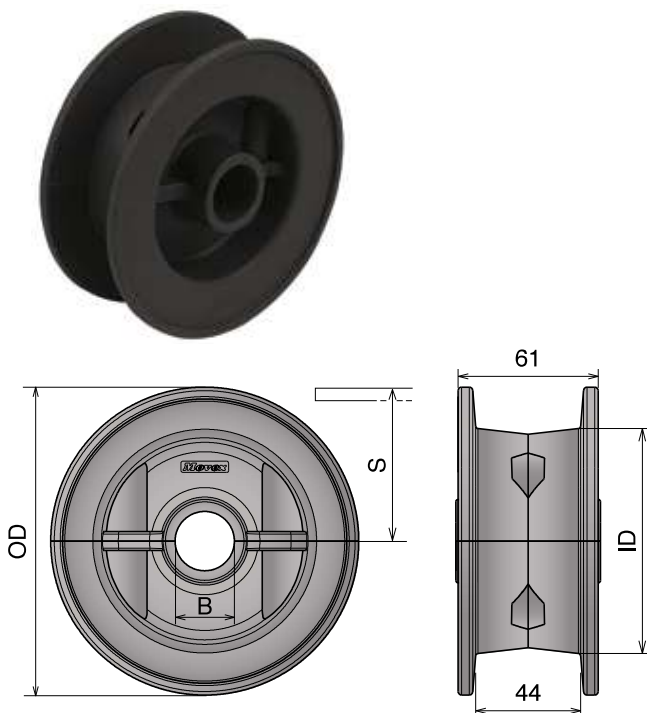

Part	Article-Nr.	ecq. Z-	Bore	OD	ID	S
608	60801	21	25	129,8	94,8	68,6
608	60802		30			
608	60803		35			
608	60804		40			
609	60901	23	25	142,2	99,3	74,6
609	60902		30			
609	60903		35			
609	60904		40			
610	61001	25	25	154,7	102,0	80,5
610	61002		30			
610	61003		35			
610	61004		40			

815 MINI Catena rettilinea Straight running chain / Geradegängige Scharnierbandkette

Pins: Martensitic 1.4057 | Backflex radius min.: 75 mm

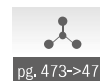
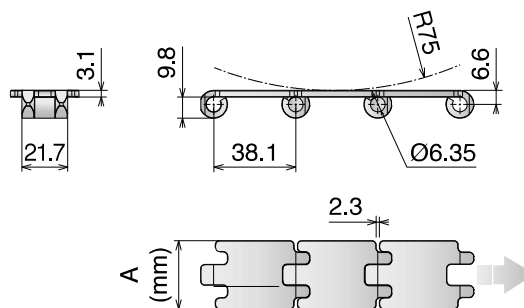

Article-Nr.	Ref.	A (Plate Width) mm	Weight kg/m	Max working load (N)	Plate Thickness mm
SSE Specially treated Ferritic Stainless Steel (1.4589) - Hardened pins					
10210117	SSE 815 K125	31,75	1,07	3000	3,1
10210118	SSE 815 K175	44,45	1,35		

815 MINI

Ruote dentate per catene / Chain sprockets / Kettenräder für Scharnierbandketten

Materiale / Material / Materialien:

Poliamide/Polyamide/Polyamid

Viti: Acciaio inox/Screws: Stainless steel/Schrauben: Edelstahl

Dadi: ferro zincato/Nuts: zinc plated steel/Mutter: verzinkter Stahl

815 MINI

Ruota traino divisa, fresata

Split drive sprocket, machined / geteiltes Antriebskettenrad gefräst

Part	Article-Nr.	Z-	Bore	PD	OD	S
580	58001	19	25	117,3	117,0	61,9
580	58002		30			
580	58003		35			
580	58004		40			
581	58101	21	25	129,3	129,0	67,8
581	58102		30			
581	58103		35			
581	58104		40			
582	58201	23	25	141,2	142,0	73,8
582	58202		30			
582	58203		35			
582	58204		40			
583	58301	25	25	153,2	154,0	79,8
583	58302		30			
583	58303		35			
583	58304		40			

Ruota rinvio divisa, fresata

Split idler sprocket, machined / geteiltes Umlenkrad, gefräst

Part	Article-Nr.	Z-	Bore	PD	OD	S
580	58050	19	18*	117,3	117,0	61,9
580	58051		25			
580	58052		30			
580	58053		35			
580	58054		40			
581	58150	21	18*	129,3	129,0	67,8
581	58151		25			
581	58152		30			
581	58153		35			
581	58154		40			
582	58250	23	18*	141,2	142,0	73,8
582	58251		25			
582	58252		30			
582	58253		35			
582	58254		40			
583	58350	25	18*	153,2	154,0	79,8
583	58351		25			
583	58352		30			
583	58353		35			
583	58354		40			

*Plain Bore

802/805

Catena rettilinea
Straight running chain / Geradegängige Scharnierbandkette

Pins: Martensitic 1.4057 | Backflex radius min.: 150 mm

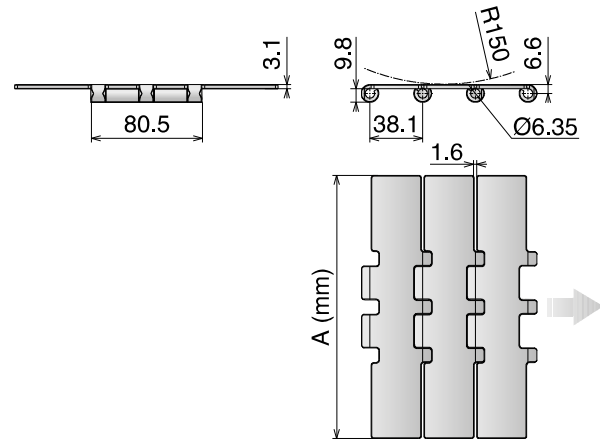

10 feet 3.048 m
80 links | pg. 86-96-105 | pg. 473->476

Article-Nr.	Ref.	A (Plate Width) mm	Weight kg/m	Surface finish µm	Max working load (N)	Plate Thickness mm
SS Ferritic Stainless Steel (1.4016)						
10030207	SS 802 K750	190,5	5,80	0,6	7000	3,1
SSE Specially treated Ferritic Stainless Steel (1.4589) - Hardened pins						
10030107	SSE 805 K750	190,5	5,80	0,3	9000	3,1
SSA Austenitic Stainless Steel (AISI 304) - Austenitic pin						
10030407	SSA 805 K750	190,5	5,80	0,6	8700	3,1

8157

Catena rettilinea
Straight running chain / Geradegängige Scharnierbandkette

Pins: Martensitic 1.4057 | Backflex radius min.: 150 mm

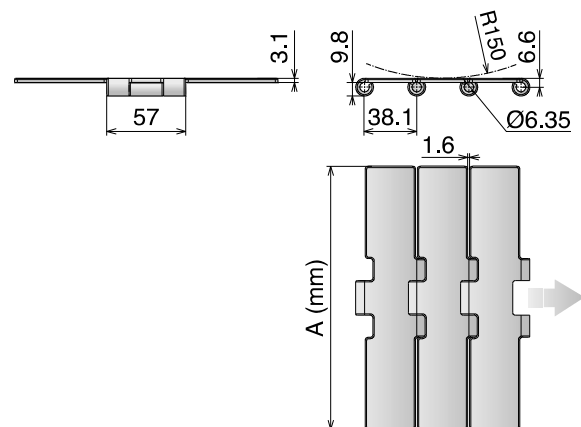

10 feet 3.048 m
80 links | pg. 87-95-106 | pg. 473->476

Article-Nr.	Ref.	A (Plate Width) mm	Weight kg/m	Surface finish µm	Max working load (N)	Plate Thickness mm
SSE Specially treated Ferritic Stainless Steel (1.4589) - Hardened pins						
10050107	SSE 8157 K750	190,5	5,60	0,3	7000	3,1

8157 GT

Catena rettilinea
Straight running chain / Geradegängige Scharnierbandkette

Pins: Martensitic 1.4057

Backflex radius min.: 150 mm

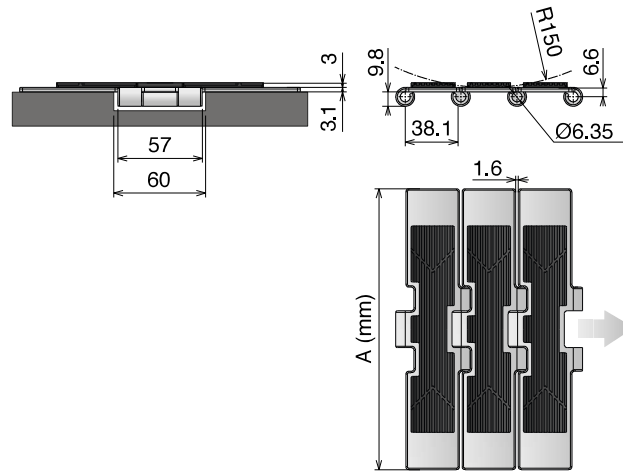

10 feet
3.048 m



pg. 87-95/106



pg. 473->476

80 links

Article-Nr.	Ref.	A (Plate Width) mm	Weight kg/m	Max working load (N)	Plate/Rubber Thickness mm
SSE Specially treated Ferritic Stainless Steel (1.4589) - Hardened pins					
10060107	SSE 8157 GT K750	190,5	6,00	10000	Plate 3,1 Rubber 3

8157

Ruota traino divisa, fresata

Split drive sprocket, machined / geteiltes Antriebskettenrad gefräst

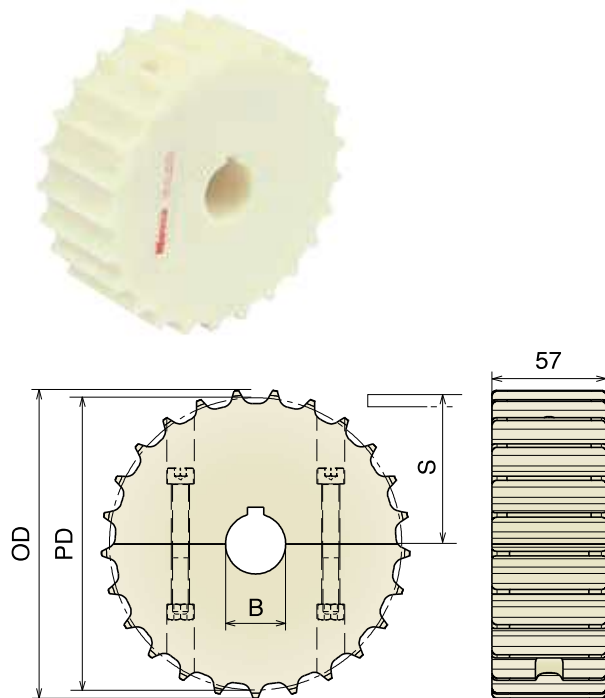

Part	Article-Nr.	Z-	Bore	PD	OD	S
528	52801	17	25	105,5	103,9	55,9
528	52802		30			
528	52803		35			
528	52804		40			
529	52901	19	25	117,3	117,0	61,9
529	52902		30			
529	52903		35			
529	52904		40			
530	53001	21	25	129,3	129,0	67,8
530	53002		30			
530	53003		35			
530	53004		40			
531	53101	23	25	141,2	142,0	73,8
531	53102		30			
531	53103		35			
531	53104		40			
532	53201	25	25	153,2	154,0	79,8
532	53202		30			
532	53203		35			
532	53204		40			
533	53301	27	25	165,2	166,8	85,8
533	53302		30			
533	53303		35			
533	53304		40			
534	53401	29	25	177,2	178,5	91,8
534	53402		30			
534	53403		35			
534	53404		40			

Ruota rinvio divisa, fresata

Split idler sprocket, machined / geteiltes Umlenkrad, gefräst

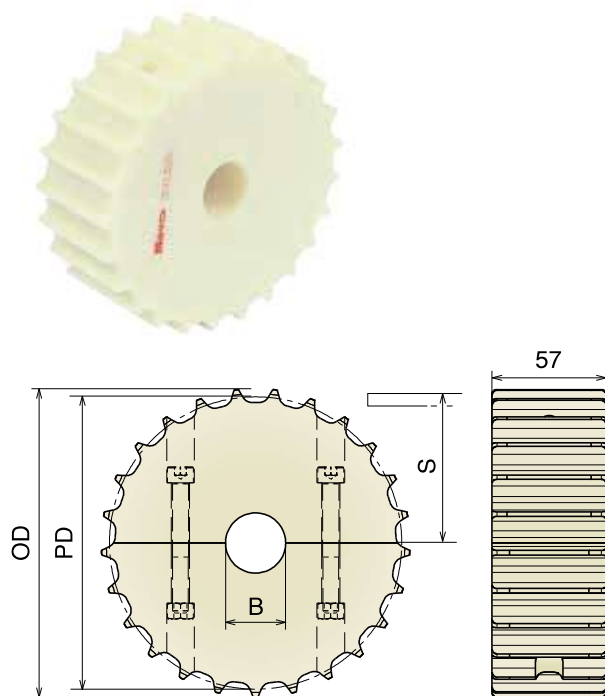

Part	Article-Nr.	Z-	Bore	PD	OD	S
528	52850	17	18*	105,5	103,9	55,9
528	52851		25			
528	52852		30			
528	52853		35			
528	52854		40			
529	52950	19	18*	117,3	117,0	61,9
529	52951		25			
529	52952		30			
529	52953		35			
529	52954		40			
530	53050	21	18*	129,3	129,0	67,8
530	53051		25			
530	53052		30			
530	53053		35			
530	53054		40			
531	53150	23	18*	141,2	142,0	73,8
531	53151		25			
531	53152		30			
531	53153		35			
531	53154		40			
532	53250	25	18*	153,2	154,0	79,8
532	53251		25			
532	53252		30			
532	53253		35			
532	53254		40			
533	53350	27	18*	165,2	166,8	85,8
533	53351		25			
533	53352		30			
533	53353		35			
533	53354		40			
534	53450	29	18*	177,2	178,5	91,8
534	53451		25			
534	53452		30			
534	53453		35			
534	53454		40			

*Plain Bore

⚙️ **Materiale / Material / Materialien:**
 Poliammide/Polyamide/Polyamid
 Viti: Acciaio inox/Screws: Stainless steel/Schrauben: Edelstahl
 Dadi: ferro zincato/Nuts: zinc plated steel/Mutter: verzinkter Stahl

815-8157

Ruote dentate per catene / Chain sprockets / Kettenräder für Scharnierbandketten

815 Ruota flangiata divisa, fresata Split sprocket with guides, machined / Geteiltes Kettenrad mit Bordscheibe, gefräst

Anelli Inox / SS Guide-rings / Edelstahl Bordscheibe



Part	Article-Nr.	Z-	Bore	PD	OD	S	Ø screw
503	50301G	21	25	129,3	129,0	67,8	104,0
503	50302G		30				
503	50303G		35				
503	50304G		40				
504	50401G	23	25	141,2	142,0	73,8	116,0
504	50402G		30				
504	50403G		35				
504	50404G		40				
505	50501G	25	25	153,2	154,0	79,8	128,0
505	50502G		30				
505	50503G		35				
505	50504G		40				

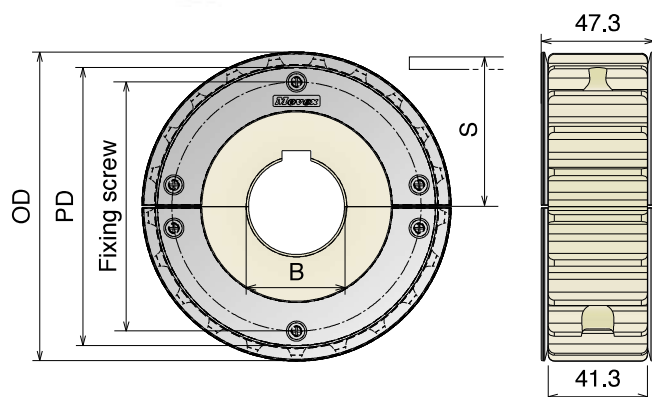

8157 Ruota flangiata divisa, fresata Split sprocket with guides, machined / Geteiltes Kettenrad mit Bordscheibe, gefräst

Anelli Inox / SS Guide-rings / Edelstahl Bordscheibe



Part	Article-Nr.	Z-	Bore	PD	OD	S	Ø screw
530	53001G	21	25	129,3	129,0	67,8	104,0
530	53002G		30				
530	53003G		35				
530	53004G		40				
531	53101G	23	25	141,2	142,0	73,8	116,0
531	53102G		30				
531	53103G		35				
531	53104G		40				
532	53201G	25	25	153,2	154,0	79,8	128,0
532	53202G		30				
532	53203G		35				
532	53204G		40				

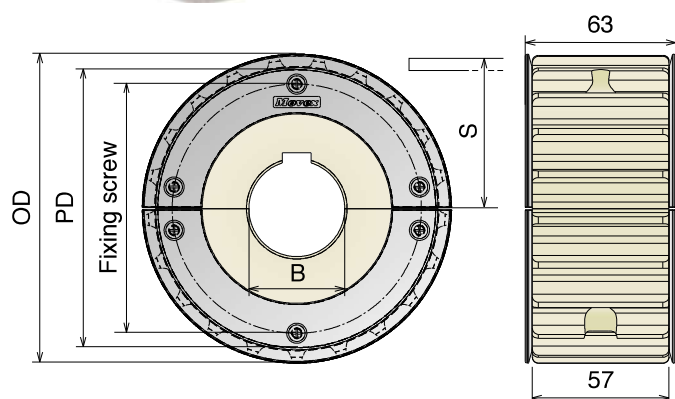

Ruote dentate per catene / Chain sprockets / Kettenräder für Scharnierbandketten

881 TAB-882 M

Ruote folli per catene / Chain idler wheels / Umlenkrollen für Scharnierbandketten

Materiale / Material / Materialien:

Poliamide/Polyamide/Polyamid

Viti: Acciaio inox/Screws: Stainless steel/Schrauben: Edelstahl

Dadi: ferro zincato/Nuts: zinc plated steel/Mutter: verzinkter Stahl

881 TAB

Ruota rinvio liscia, divisa, fresata
Split idler wheel, machined / geteilte Umlenkrolle, gefräst

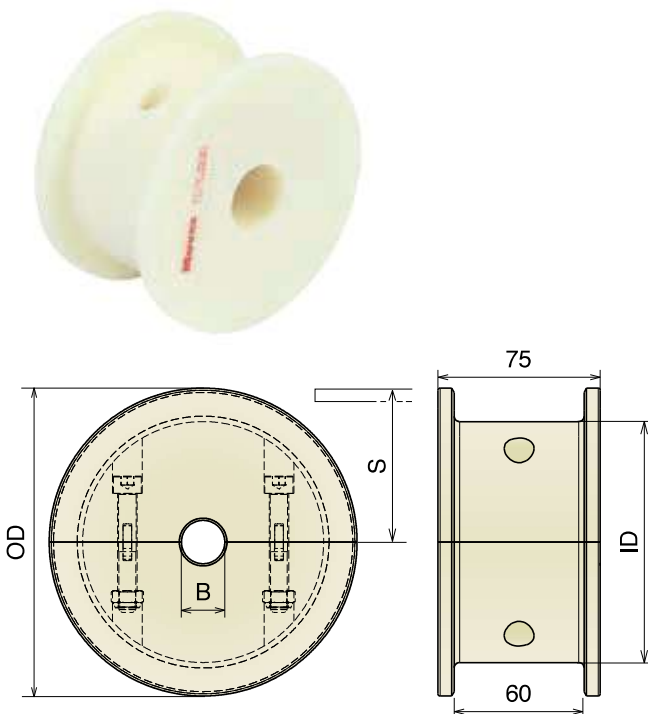

Part	Article-Nr.	ecq. Z.	Bore	OD	ID	S
618	61800	17	20	104,0	66,0	56,2
618	61801		25			
618	61802		30			
618	61803		35			
618	61804		40			
619	61900	19	20	117,0	75,0	62,6
619	61901		25			
619	61902		30			
619	61903		35			
619	61904		40			
620	62000	21	20	129,8	95,0	68,6
620	62001		25			
620	62002		30			
620	62003		35			
620	62004		40			
621	62100	23	20	142,2	108,0	74,6
621	62101		25			
621	62102		30			
621	62103		35			
621	62104		40			
622	62200	25	20	154,7	112,0	80,5
622	62201		25			
622	62202		30			
622	62203		35			
622	62204		40			
623	62300	27	20	167,2	120,0	88,5
623	62301		25			
623	62302		30			
623	62303		35			
623	62304		40			
624	62400	29	20	179,3	130,0	92,8
624	62401		25			
624	62402		30			
624	62403		35			
624	62404		40			

882 M

Ruota rinvio liscia, divisa, fresata
Split idler wheel, machined / geteilte Umlenkrolle, gefräst

Also suitable for Series 8257 - 8157 - 8857 M

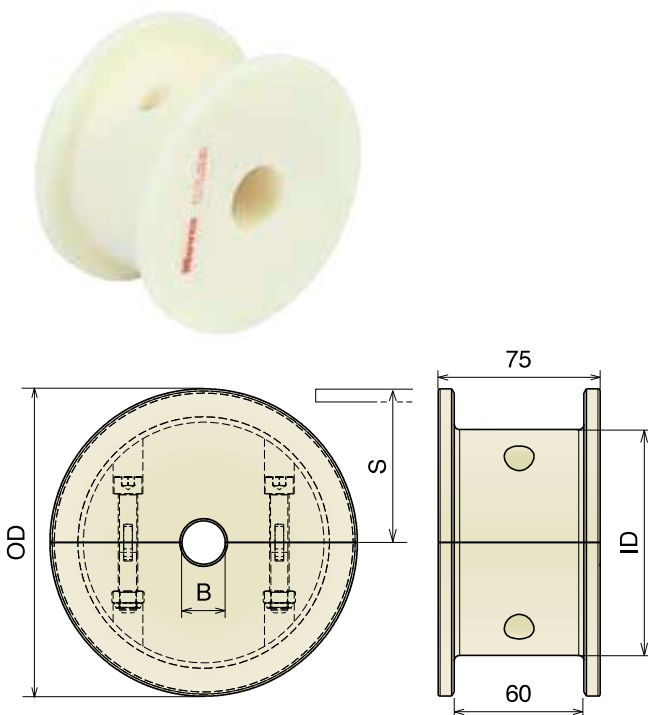

Part	Article-Nr.	ecq. Z.	Bore	OD	ID	S
629	62900	17	20	104,0	75,2	56,2
629	62901		25			
629	62902		30			
629	62903		35			
629	62904		40			
630	63000	19	20	117,0	92,2	62,6
630	63001		25			
630	63002		30			
630	63003		35			
630	63004		40			
631	63100	21	20	129,8	105,0	68,6
631	63101		25			
631	63102		30			
631	63103		35			
631	63104		40			
632	63200	23	20	142,2	111,3	74,6
632	63201		25			
632	63202		30			
632	63203		35			
632	63204		40			
633	63300	25	20	154,7	124,7	80,5
633	63301		25			
633	63302		30			
633	63303		35			
633	63304		40			
634	63400	27	20	167,2	135,0	88,5
634	63401		25			
634	63402		30			
634	63403		35			
634	63404		40			
635	63500	29	20	179,3	140,0	92,8
635	63501		25			
635	63502		30			
635	63503		35			
635	63504		40			

Material Chemical Resistances

Chemical Agent up to 65°C	Polyamide	Steel	Stainless Steel Aisi 304	Stainless Steel Aisi 430	LF	MX	UHMW PE	PP/PPX
Acetone	G	U	G	G	G	A	G	G
Acetic acid (max 5%)	U	U	G	U	U	G	G	G
Alcohol	G	G	G	G	G	G	G	G
Ammonia	G	A	G	G	U	A	G	G
Beer	G	G	G	G	G	G	G	G
Benzene	G	G	G	G	G	U	A	G
Benzol	G	G	G	G	G	G	G	A
Carbon tetrachloride	G	A	A	A	G	/	A	U
Chocolat	A	G	G	G	G	G	A	G
Citric acid	A	U	G	A	A	G	G	G
Formic acid	U	G	G	G	G	A	G	/
Fresh water	G	U	G	G	G	G	G	G
Fruit juices	G	U	G	A	G	G	G	G
Hydrochloric acid (max 2%)	U	U	U	U	U	A	A	G
Hydrogen peroxide	U	U	G	A	U	/	A	/
Iodine	U	A	A	A	A	/	A	/
Lactic acid	G	U	G	U	G	G	G	G
Milk	G	G	G	G	G	G	G	G
Mustard	A	G	G	G	A	/	A	G
Nitric acid	U	U	G	A	U	U	A	G
Oil (vegetable or mineral)	G	G	G	G	G	U	G	G
Paraffin	G	G	G	G	G	G	G	/
Petrol	G	G	G	G	G	G	A	G
Phosphoric acid (max 10%)	U	U	G	U	U	U	G	G
Sea water	U	A	G	A	G	G	G	G
Soap and water	G	A	G	G	G	G	G	G
Sodium hydrochloride	G	U	A	U	G	A	G	G
Sodium hydroxide (max 25%)	G	U	G	G	U	U	G	/
Sodium hypochlorite	G	U	U	U	U	A	G	G
Soft Drinks	G	G	G	G	G	G	G	G
Spirits	G	G	G	G	G	G	G	G
Sulphide acid	U	U	U	U	U	G	U	G
Toluene	U	U	U	U	G	G	A	G
Turpentine	U	G	G	G	U	G	A	/
Vegetable juices	G	A	G	G	G	G	G	G
Vinegar	G	U	A	U	G	G	G	G
Whisky	G	G	G	G	G	G	G	G
Wine	G	G	G	G	G	G	G	G
Xilol	U	U	U	U	U	G	U	U

LEGENDA

G: Good / A: Average / U: Unsatisfactory

SS



Materials

Description

Ferritic Stainless Steel (1.4016)
for standard applications.

General information

Material abbreviation	Material	Chemical abbreviation	Allowable application temperatures						FDA Approval
			Fahrenheit			Celsius			
			Min	Max		Min	Max		
				Dry	Wet		Dry	Wet	
SS	Standard Stainless Steel	1.4016	-22	750	265	-30	400	130	-

Friction Factors Between Material and Product

Lubrication	Product Material					
	Paper & carton	Metal (steel)	Aluminium	Plastics & PET	Glass (returnable)	Glass (new)
Dry	0,40	0,50	0,35	0,30	0,47	0,35
Water	n.a.	0,35	0,30	0,25	0,31	0,30
W&s & Dry lube	n.a.	0,20	0,15	0,15	0,21	0,15
Oil	n.a.	0,20	n.a.	n.a.	n.a.	n.a.

Friction Factors Between Material and Product

Lubrication	Wearstrip Material		
	Stainless steel	UHMW-PE & PA	<i>BluLub</i> ®
Dry	n.a.	0,35	0,32
Water	0,40	0,27	0,24
W&s & Dry lube	0,20	0,18	0,15
Oil	0,20	0,18	0,15

Note

Material properties and performance of final product are subject to variation according to operating conditions, e.g. environmental conditions, chemicals, cleanliness.

SSE



Materials

Description

Specially treated Ferritic Stainless Steel (1.4589)
for improved working-load and less friction.

General information

Material abbreviation	Material	Chemical abbreviation	Allowable application temperatures						FDA Approval
			Fahrenheit			Celsius			
			Min	Max		Min	Max		
				Dry	Wet		Dry	Wet	
SSE	Special Stainless Steel	1.4589	-22	750	265	-30	400	130	-

Friction Factors Between Material and Product

Lubrication	Product Material					
	Paper & carton	Metal (steel)	Aluminium	Plastics & PET	Glass (returnable)	Glass (new)
Dry	0,38	0,48	0,33	0,29	0,45	0,33
Water	n.a.	0,33	0,29	0,24	0,29	0,29
W&s & Dry lube	n.a.	0,19	0,14	0,14	0,20	0,14
Oil	n.a.	0,19	n.a.	n.a.	n.a.	n.a.

Friction Factors Between Material and Product

Lubrication	Wearstrip Material		
	Stainless steel	UHMW-PE & PA	<i>BluLub</i> ®
Dry	n.a.	0,33	0,30
Water	0,38	0,26	0,23
W&s & Dry lube	0,19	0,17	0,14
Oil	0,19	0,17	0,14

Note

Material properties and performance of final product are subject to variation according to operating conditions, e.g. environmental conditions, chemicals, cleanliness.

SSM



Materials

Description**Specially treated Ferritic SS (1.4589)**

with optimized surface finish for superior sliding properties. For High-Speed and more critical applications.

General information

Material abbreviation	Material	Chemical abbreviation	Allowable application temperatures						FDA Approval
			Fahrenheit			Celsius			
			Min	Max		Min	Max		
				Dry	Wet		Dry	Wet	
SSM	Max Speed Stainless Steel	1.4589	-22	750	265	-30	400	130	-

Friction Factors Between Material and Product

Lubrication	Product Material					
	Paper & carton	Metal (steel)	Aluminium	Plastics & PET	Glass (returnable)	Glass (new)
Dry	0,34	0,43	0,30	0,26	0,40	0,30
Water	n.a.	0,30	0,26	0,21	0,26	0,26
W&s & Dry lube	n.a.	0,17	0,13	0,13	0,18	0,13
Oil	n.a.	0,17	n.a.	n.a.	n.a.	n.a.

Friction Factors Between Material and Product

Lubrication	Wearstrip Material		
	Stainless steel	UHMW-PE & PA	<i>BluLub</i> [®]
Dry	n.a.	0,32	0,29
Water	0,36	0,24	0,22
W&s & Dry lube	0,18	0,16	0,14
Oil	0,18	0,16	0,14

Note

Material properties and performance of final product are subject to variation according to operating conditions, e.g. environmental conditions, chemicals, cleanliness.

SSA

**Description**

Austenitic Stainless Steel with high resistance to corrosion and acid (AISI 304)
for improved working-load and less friction.

General information

Material abbreviation	Material	Chemical abbreviation	Allowable application temperatures						FDA Approval
			Fahrenheit			Celsius			
			Min	Max		Min	Max		
				Dry	Wet		Dry	Wet	
SSA	Austenitic Stainless Steel	AISI 304	-22	750	265	-30	400	130	-

Friction Factors Between Material and Product

Lubrication	Product Material					
	Paper & carton	Metal (steel)	Aluminium	Plastics & PET	Glass (returnable)	Glass (new)
Dry	0,43	0,38	0,34	0,30	0,33	0,33
Water	n.a.	0,30	0,27	0,21	0,29	0,29
W&s & Dry lube	n.a.	0,15	0,14	0,14	0,15	0,15
Oil	n.a.	n.a.	n.a.	n.a.	n.a.	n.a.

Friction Factors Between Material and Product

Lubrication	Wearstrip Material		
	Stainless steel	UHMW-PE & PA	<i>BluLub</i> ®
Dry	0,40	0,30	0,30
Water	0,35	0,22	0,22
W&s & Dry lube	0,15	0,15	0,15
Oil	0,15	0,10	0,10

Note

Material properties and performance of final product are subject to variation according to operating conditions, e.g. environmental conditions, chemicals, cleanliness.